

REVISION RECORD

REV	ECN	DESCRIPTION	DRFT	DATE
-----	-----	-------------	------	------

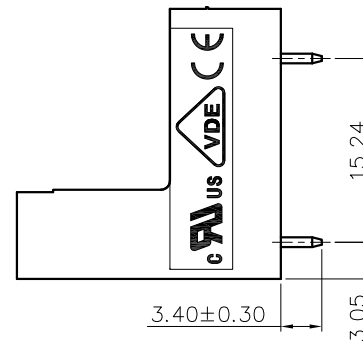
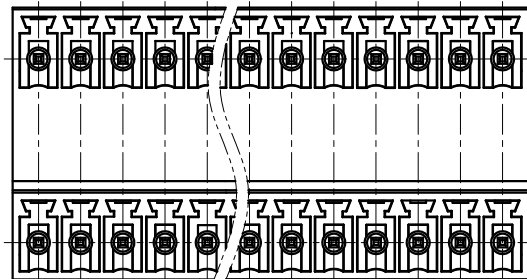
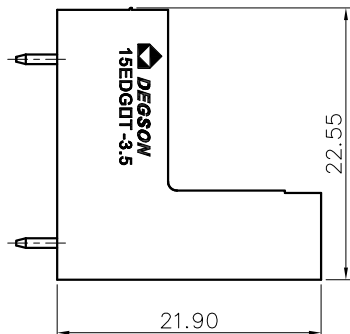

NOTES1:

UL Standard

1. Rated voltage/current : 300V / 8A
2. Withstanding voltage : AC1600V/1Min.

IEC Standard

1. Pollution Degree	2
Overtoltage Category	II
Rate Impulse Voltage(KV)	2.5KV
Rate Voltage(V)	250V
Rate Current(A)	7A

NOTES2:

1. Dimension shall be interpreted per ASME Y14.5-2009
2. Pitch : 3.5/3.81mm, Poles : N=04~48P
3. Operating temperature: -40°C~+105°C
4. Undimensioned tolerances:

Pitch range in mm			Nominal dimension range in mm			-	∩	∇
TO	Over TO	Over TO	TO	Over TO	Over TO	0.1/10		
6	6 TO 10	10 TO 24	30	30 TO 60	60 TO 100	100 TO 150	150	±2'
	±0.15	±0.20	±0.30	±0.30	±0.50	±0.70	±1.00	±1.30

5. RoHS Compliance

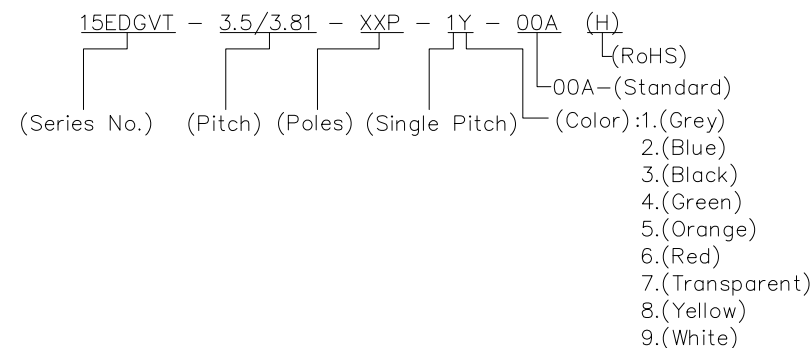
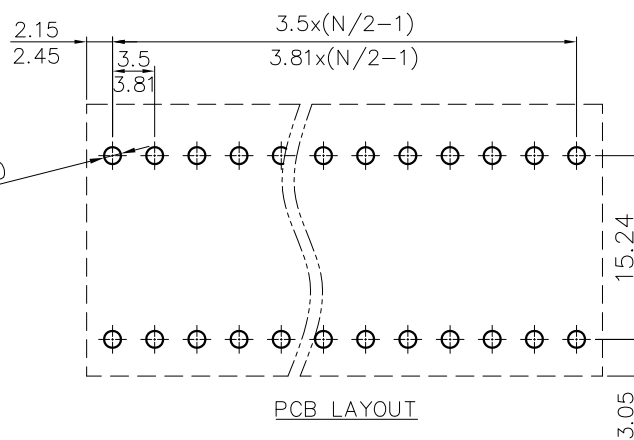
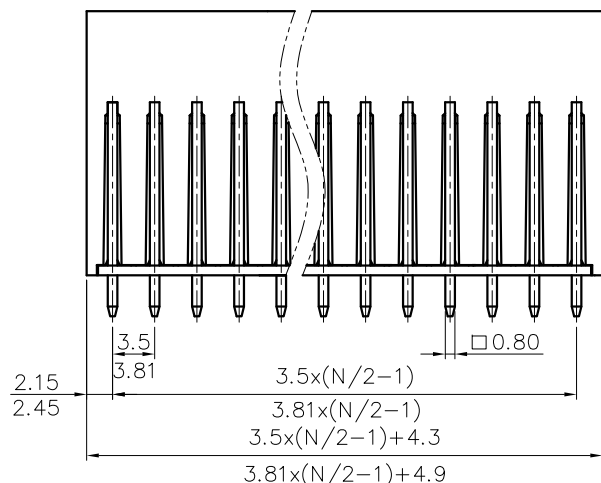

DETACHED LISTS	PART NO.:	宁波高松电子有限公司 NINGBO DEGSON ELECTRICAL CO., LTD			
	APPD:	NAME: 15EDGVT-3.5/3.81-XXP-1Y-00A(H)			
	CHKD:	TITLE: CUSTOMER DRAWING			
	DRFT:	DRAWING NO.:		REV	DO
THIRD ANGLE PROJECTION		DO NOT SCALE DRAWING		SHEET	1/1
		MM (INCH)		SCALE	1:1