

Typical Performance

- Wide input voltage range(4:1),Output 6W
- Conversion efficiency91%(Typ)
- Isolation voltage 1500Vdc
- Ultra-low standby power consumption:0.036W
- Super fast startup:1mS(typical value)
- Working temperature range:-40°C~+85°C
- Input undervoltage, output short circuit, overcurrent. overvoltage protection
- Metal case, low output ripple
- International standard pins, PCB board in-line

6W,Ultra-Wide Voltage Input, Isolated Regulated Single/Dual, DIP Package
DC-DC Power Module



RoHS

HLK-UR(A)B_YMD-6WR3(H) series product output power is 6W, 4:1 wide voltage input range, efficiency up to 91%, conventional isolation voltage of 1500VDC, allowable operating temperature -40°C to +85°C, with Input under-voltage protection, output over-voltage, over-current, short-circuit protection functions, bare metal meets CISPR32/EN55032 CLASS A, widely used in medical, industrial control, electric power, instrumentation, communication, railway and other fields.

Product Coding Rules

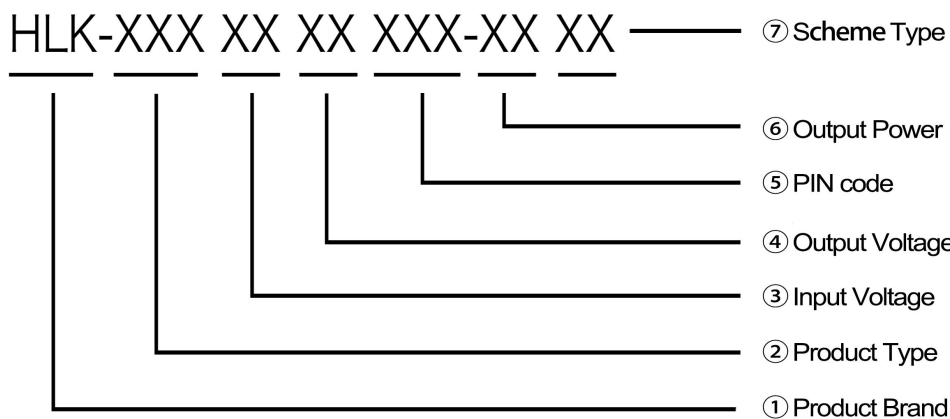

Product Mode List

Certification	Product Mode①	Input Voltage range (Vdc)		Output Voltage/Current		Ripple and Noise	Maximum capacitance	Efficiency @ full load
		Nominal value② (range value)	Max	Output voltage (Vdc)	Output current (mA) (Max.Min.)	Full load (mVp-p) (TPY/Max.)	μF Max.	% (Min/TPY)
	URB2403YMD-6WR3	24 (9-36)	40	3.3	1400/0	30/50	2500	80/82
	URB2405YMD-6WR3			5	1200/0	30/50	2200	83/85

URB2412YMD-6WR3			12	500/0	50/80	680	87/89
URB2415YMD-6WR3			15	400/0	50/80	470	88/90
URB2424YMD-6WR3			24	250/0	50/80	220	89/91
URA2405YMD-6WR3			±5	±600/0	30/50	1100	83/85
URA2412YMD-6WR3			±12	±250/0	50/80	330	86/88
URA2415YMD-6WR3			±15	±200/0	50/80	220	88/90
URA2424YMD-6WR3			±24	±125/0	50/80	100	89/91
URB4803YMD-6WR3	48 (18-75)	80	3.3	1400/0	30/50	2500	80/82
URB4805YMD-6WR3			5	1200/0	30/50	2200	83/85
URB4812YMD-6WR3			12	500/0	50/80	680	87/89
URB4815YMD-6WR3			15	400/0	50/80	470	88/90
URB4824YMD-6WR3			24	250/0	50/80	220	89/91
URA4805YMD-6WR3			±5	±600/0	30/50	1100	83/85
URA4812YMD-6WR3			±12	±250/0	50/80	330	86/88
URA4815YMD-6WR3			±15	±200/0	50/80	220	88/90
URA4824YMD-6WR3			±24	±125/0	50/80	100	89/91
URB11003YMD-6WR3			110 (40-160)	180	3.3	1400/0	30/50
URB11005YMD-6WR3	5	1200/0			30/50	2200	83/85
URB11012YMD-6WR3	12	500/0			50/80	680	87/89
URB11015YMD-6WR3	15	400/0			50/80	470	88/90
URB11024YMD-6WR3	24	250/0			50/80	220	89/91
URA11005YMD-6WR3	±5	±600/0			30/50	1100	83/85
URA11012YMD-6WR3	±12	±250/0			50/80	330	86/88
URA11015YMD-6WR3	±15	±200/0			50/80	220	88/90
URA11024YMD-6WR3	±24	±125/0			50/80	100	89/91

- Note:**
1. Due to limited space, the above is just a list of typical products. If you need products other than the list, please contact the sales department of our company.
 2. The maximum capacitive load indicates the maximum capacitive load that can be connected to +Vo or -Vo. If it exceeds this value, the product will not be able to start normally.

Test conditions: Without specified needs, all parameter tests are measured at nominal input voltage, purely resistive rated load and 25°C room temperature.

Input Characteristics

Items	Working Conditions	Min.	Typ.	Max.	Unit
Input current (fully loaded/unloaded)	24VDC nominal input series, nominal , nominal input voltage	3.3V	-	235/1	241/2
		others	-	294/1	301/2
	48VDC nominal input series, nominal , nominal input voltage	3.3V	-	118/0.5	121/1
		others	-	147/0.5	151/1
	1110VDC nominal input series, nominal , nominal input voltage	3.3V	-	51/0.3	53/0.5
		others	-	64/0.3	66/0.5

Reflected Ripple Current	24VDC nominal input series, nominal , nominal input voltage	-	40	-	mA
	48VDC nominal input series, nominal , nominal input voltage	-	30	-	
	110VDC nominal input series, nominal , nominal input voltage	-	20	-	
Impulse voltage (Isec.max)	24VDC nominal input series, nominal , nominal input voltage	-0.7	-	50	VDC
	48VDC nominal input series, nominal , nominal input voltage	-0.7	-	100	
	110VDC nominal input series, nominal , nominal input voltage	-0.7	-	200	
Starting voltage	24VDC nominal input series, nominal , nominal input voltage	-	-	9	VDC
	48VDC nominal input series, nominal , nominal input voltage	-	-	18	
	110VDC nominal input series, nominal , nominal input voltage	-	-	40	
Input undervoltage protection	24VDC nominal input series, nominal , nominal input voltage	5.5	6.5	-	VDC
	48VDC nominal input series, nominal , nominal input voltage	12	15.5	-	
	110VDC nominal input series, nominal , nominal input voltage	32	36	-	
Start Time	Nominal input voltage and constant resistance load	-	1	-	mS
Input filter type		PI			
Hot plug		Not available			
Remote control (Ctrl) *	module open	Ctrl floating or connected to TTL high level			
	module close	Ctrl is connected to GND or low level			
	Input current at shutdown	-	0	1	mA

Note: *Ctrl control pin voltage is relative to input pin GND

Output Characteristics

Items	Working and test conditions	+Vo1			-Vo2		
		Min.	Typ.	Max.	Min.	Typ.	Max.
output load	Load percentage	0%	-	100%	0%	-	100%
Output Voltage Accuracy		-	±1.0%	±2.0%	-	±2.0%	±3.0%
Linear adjustment rate	Input voltage range	-	±0.2%	±0.5%	-	±1.5%	±2%
Load Regulation	20% ~ 100% rated load, balanced load	-	±0.5%	±1%	-	±4.0%	±5.0%

Ripple & Noise	Pure resistive load, 20MHz bandwidth, peak-to-peak	-	50mVp-p	80mVp-p	-	50mVp-p	80mVp-p
startup delay time		-	1ms	-	-	1ms	-
Output voltage regulation	Input voltage range	-	No adjustment	-	-	No adjustment	-
Dynamic Response Step Deviation	25% nominal load step	-	±3.0%	±5.0%	-	±3.0%	±5.0%
Dynamic response recovery time		-	300μs	500μs	-	300μs	500μs
Output overvoltage protection	Full voltage range input	110% Vo	-	160%Vo			
Output overcurrent protection	Full voltage range input	110% Io	150% Io	200% Io			
Output short circuit protection	Full voltage range input	sustainable, self-healing					

Notes:

- ①For product models with output voltages of $\pm 5\text{VDC}$ and $\pm 9\text{VDC}$, under 0% - 5% load conditions, the maximum output voltage accuracy is $\pm 5\%$;
- ②When tested under 0%-100% load working conditions, the index of load regulation rate is $\pm 5\%$;
- ③0%-5% load ripple & noise less than or equal to $5\%V_o$. Ripple and noise test method Twisted pair test method, which can add capacitive load at the output to reduce light load ripple.

General Characteristics

Items	Working conditions	Min.	Typ.	Max.	Units
Insulation voltage	Input-output, test time is 1 minute, leakage current is less than 1mA	1500	--	--	VDC
Insulation resistance	Input-output, insulation voltage 500VDC	1000	--	--	MΩ
Isolation Capacitor	Input-output, 100KHz/0.1V	--	1000	--	pF
Working temperature	Using the Reference Temperature Derating Curve	-40	--	+85	°C
Storage temperature		-40	--	+125	
Operating maximum case temperature		--	--	+100	
Storage humidity	no condensation	5	--	95	%RH
Pin Soldering Temperature	Solder joint distance from shell 1.5mm,10 seconds	--	--	+300	°C
On-off level	PWM model	--	250	--	KHz
Shock		10-55Hz, 10G, 30 Min. along X, Y and Z			
Shell material		Aluminum shell			
Minimum time between failures	MIL-HDBK-217F@25°C	--	2X105	--	Hrs

Product Characteristic Curve

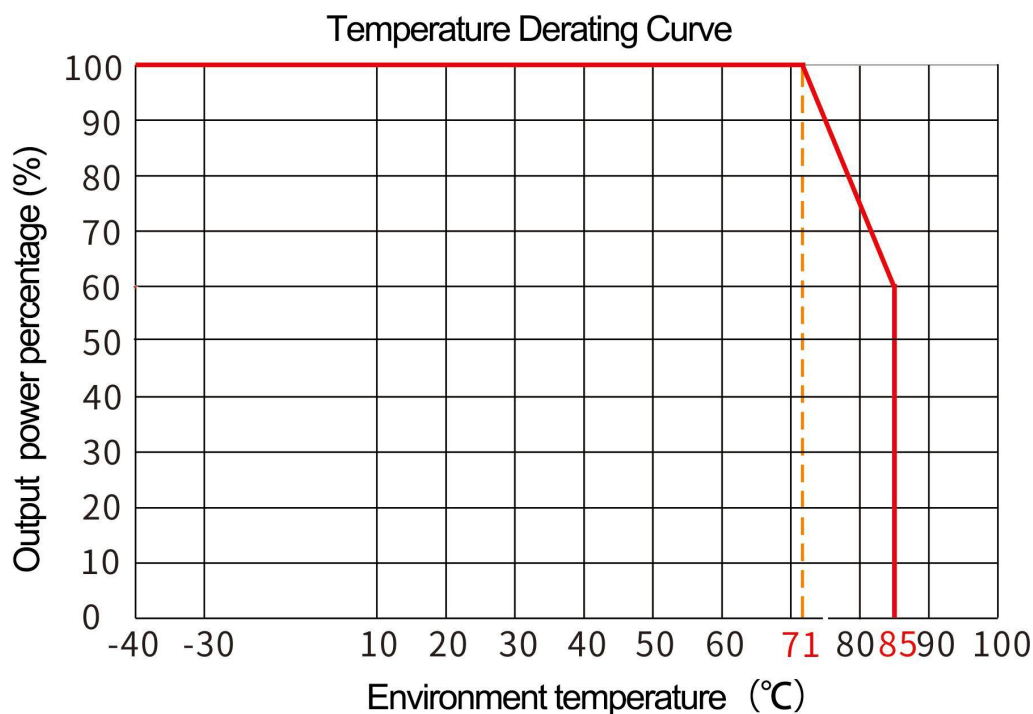

EMC Peripheral Recommended Circuit

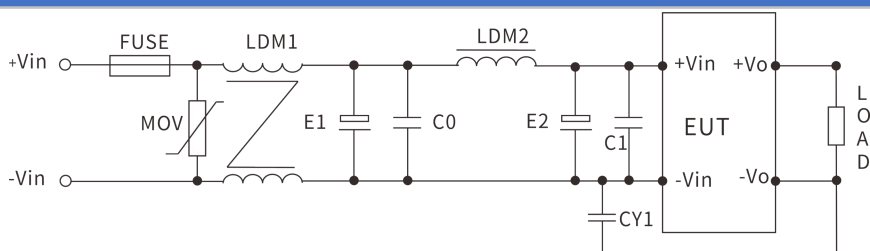

Parameter recommendation: the following are typical parameters, please adjust according to the actual use environment

Device code	24V input product	48V input product	110V input product
FMSE fuse	Access the corresponding fuse according to customer needs		
MOV Varistor	14D560K	14D101K	14D201K
LDM1 common mode inductance	10 mH	15 mH	30 mH
E1、E2 Electrolytic capacitor	100 μ F/50V	100 μ F/100V	63 μ F/200V
C0、C1 Ceramic capacitors	1 μ F/50V	1 μ F/100V	0.47 μ F/250V
LDM2 Differential Mode Inductance	10 μ H	15 μ H	68 μ H
CY1 safety Y2 capacitor	1nF/250Vac		

Output Filter Peripheral Recommended Circuit

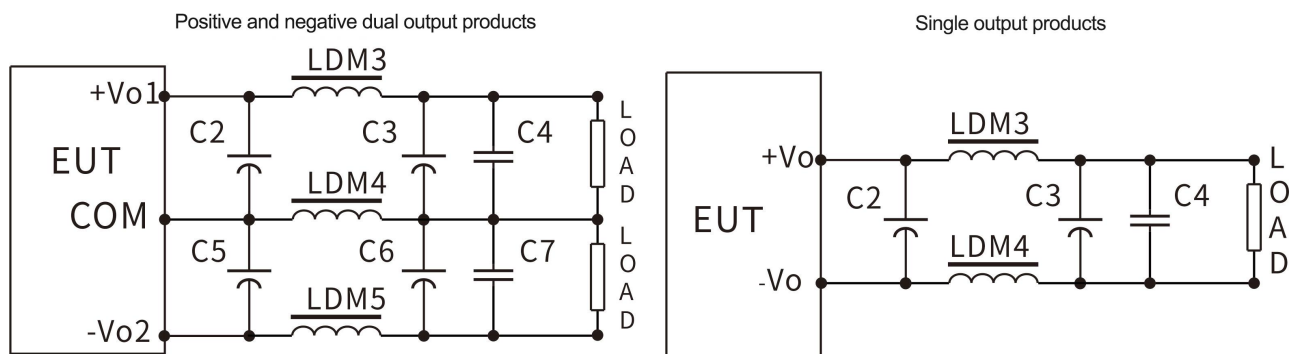

When the requirements for ripple & noise are general, it is recommended to use only C2 and C5 for the periphery;
When the requirements for ripple & noise are strict; the circuit shown above is recommended.

Note: 1. C2, C3, C5, C6 use high-frequency low-resistance electrolytic capacitors, and the total capacity cannot exceed the maximum capacitive load marked in the manual, otherwise the module will not be able to start normally.

2. When the capacitive load is used, the minimum load of 3% must be guaranteed, otherwise the module output will be abnormal.

3. LDM5 is only used for dual output products.

Parameter recommendation :

Device code	3.3V output	±5V or 5V output	±9V/12V or 9V/12V output	±15V or 15V output	±24V or 24V output
LDM3 inductance	0.47μH	1μH	2.2 μH	2.2 μH	4.7 μH
LDM4 inductance	0.47μH	1μH	2.2 μH	2.2 μH	4.7 μH
LDM5 inductance	-	1μH	2.2 μH	2.2 μH	4.7 μH
C2、C3 Electrolytic capacitor	220μF	220μF	100μF	100μF	68μF
C5、C6 Electrolytic capacitor	220μF	220μF	100μF	100μF	68μF
C4、C7 Ceramic capacitors	1μF/50V				

Package size and Pin Function Diagram

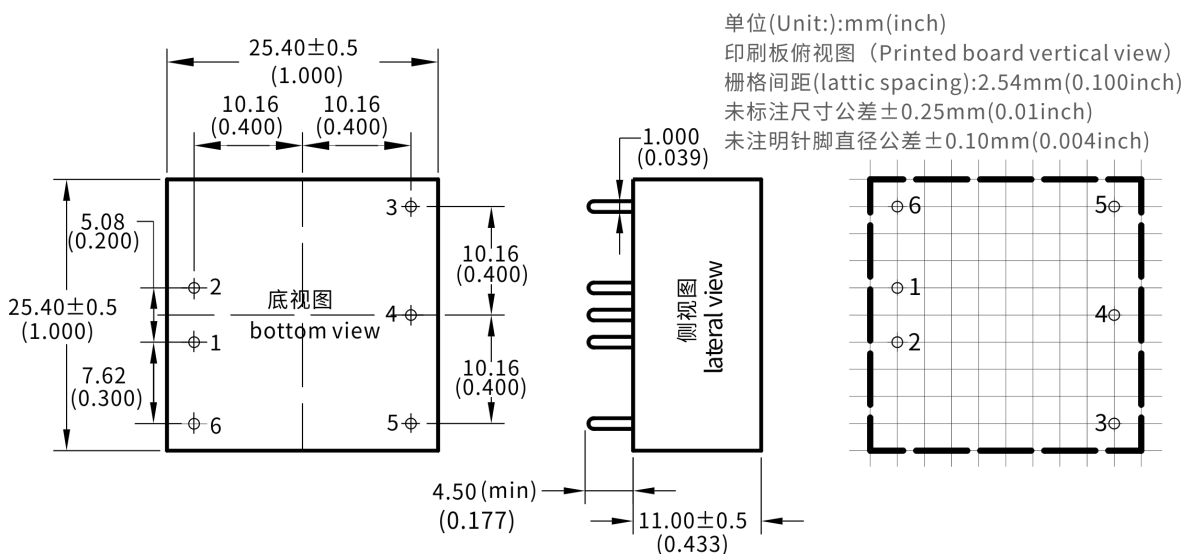

Single(S)	1	2	3	4	5	6
	-Vin	+Vin	+Vo	NP	GND	NC
Dual(D)	- Input	+ Input	+ Output	empty feet	output ground	empty feet
	-Vin	+Vin	+Vo1	COM	-Vo2	NC
	- Input	+ Input	+ output 1	Common end	- Output 2	empty feet

*Notes: If the definition of each pin of the power module is inconsistent with the selection manual, the label on the physical label shall prevail. (Be sure to pay attention to the direction of the silk screen)

Package Description

Package code	L x W x H	
A3	25.4 X25.4X11.0mm	1.000X 1.000 X0.433 inch

Test Application Reference

Recommended test circuit 1. DC/DC test circuit:

General recommended capacitance: C1: 47-100 μ F; C2, C3: 10-22 μ F

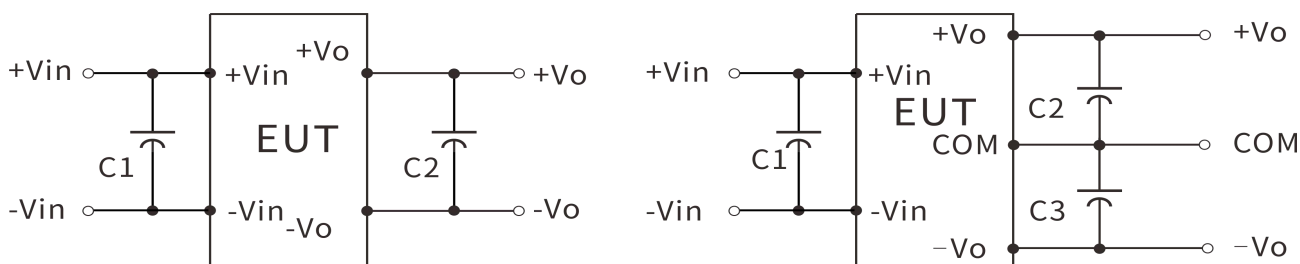

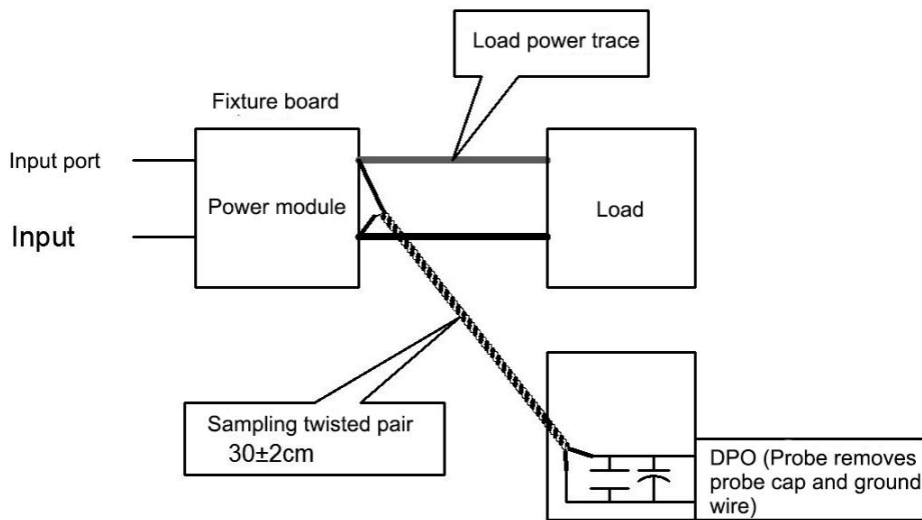

2、Ripple & noise test: (twisted pair method 20MHZ bandwidth)

Test way :

1. Ripple noise is connected by 12# twisted pair cable, the bandwidth of the oscilloscope is set to 20MHz, the bandwidth of the probe is 100M, and a 0.1uF polypropylene capacitor and a 47uF high-frequency low-resistance electrolytic capacitor are connected in parallel on the probe end, and the oscilloscope sampling uses the Sample sampling mode .

2. Schematic diagram of output ripple noise test:

Connect the power input terminal to the input power supply, and the power output is connected to the electronic load through the fixture board. The test uses a 30cm \pm 2 cm sampling line to directly sample from the power output port. The power line selects the wire with the insulation sheath of the corresponding wire diameter according to the magnitude of the output current.

Contact Way

Shenzhen Hi-Link Electronic Co.,Ltd

Add: Room 301, Building 1, 1970 Science & Technology Park, Minzhi Community, Minzhi Street, Longhua District, Shenzhen

Web: www.hlktech.com

Email: sales@hlktech.com

Tel: 0755-23152658