

NOTES

1. MATERIAL: SEE CHART
2. FINISH: SEE CHART
3. PRODUCT SPECIFICATION: PS-5556-001, PS-5556-002, PS-5556-003
4. PACKAGING SPECIFICATION: PK-5558-001 FOR CHAIN
PK-5556-003 FOR LOOSE
5. MATES WITH TERMINAL: 5556 SERIES.
6. APPLICABLE HOUSING: 5559, 30068, 42475 SERIES.
7. THE NUMBER OF SERRATIONS TO BE ONE FOR WIRE RANGE #22-28.
8. WHEN TERMINALS ARE INSTALLED IN THE HOUSING THE WIRES ARE TO BE DRESSED IN SUCH A MANNER TO ALLOW THE TERMINALS TO FLOAT FREELY IN THE POCKET.
9. THIS TERMINAL IS DESIGNED FOR SINGLE WIRE CRIMPING.
10. PART CONFORMS TO CLASS "B" REQUIREMENTS OF COSMETIC SPECIFICATION PS-45499-002.
11. TEXT ON PART IS FOR REFERENCE ONLY. TEXT AND TEXT LOCATION MAY VARY DEPENDING ON PART NUMBER AND/OR TOOL.

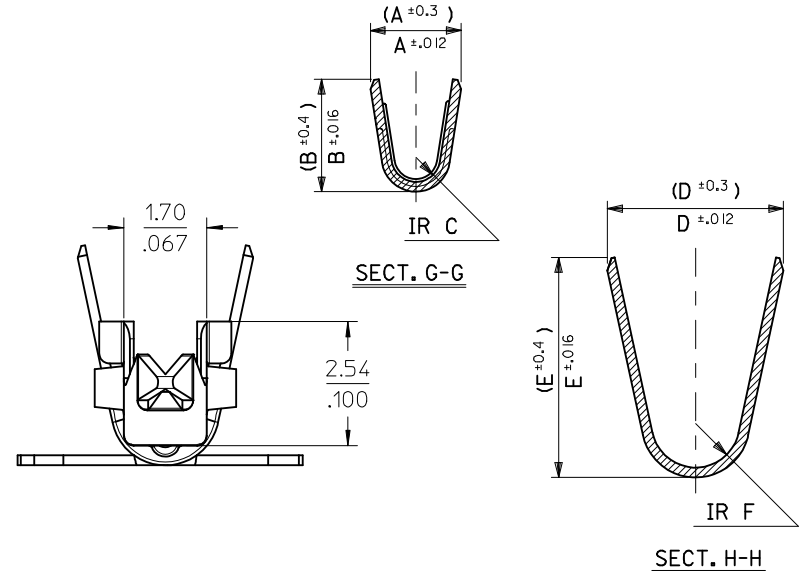
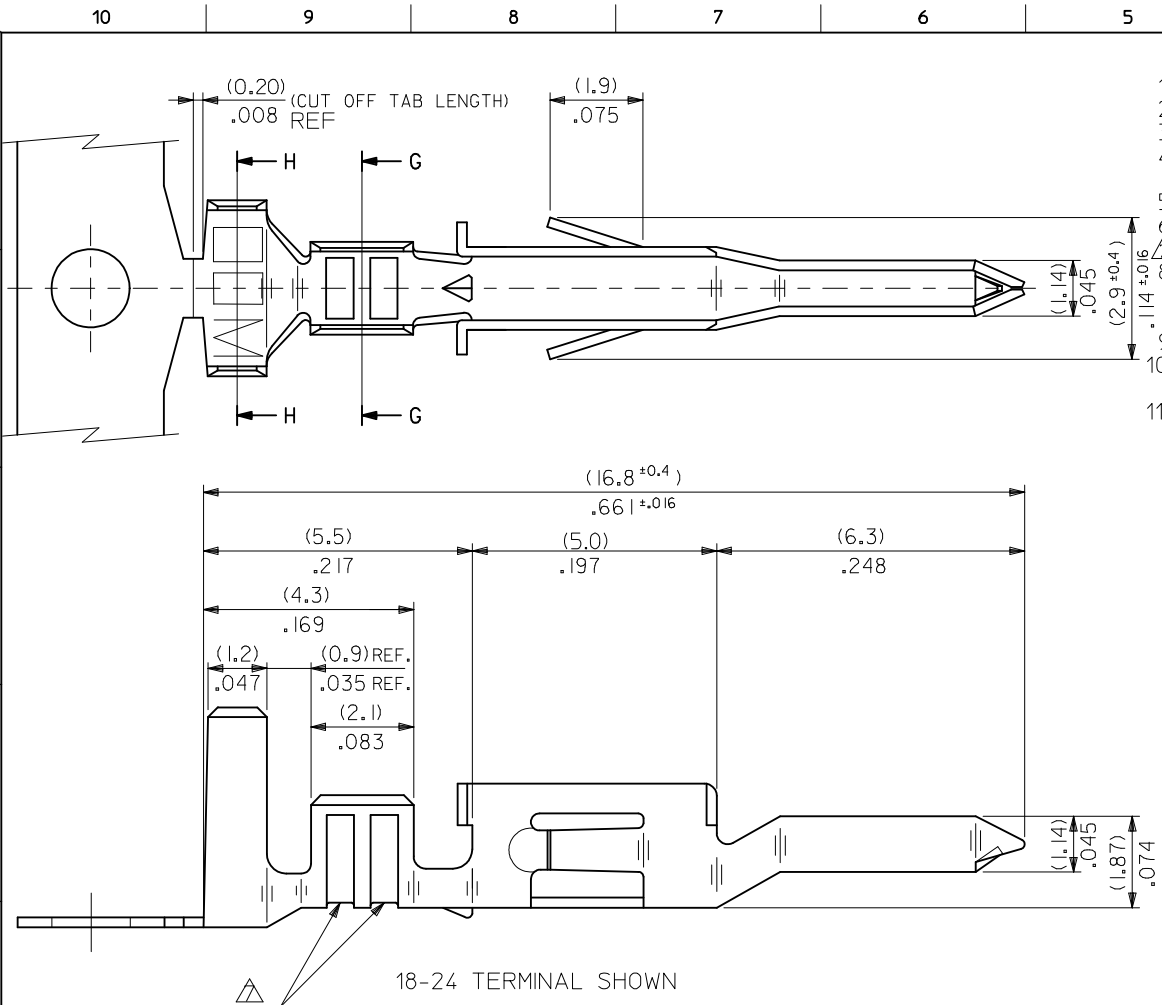

ADD FRONT VIEW EC NO: UCP2017-1893 DRAWN: GLAFTER 2017/02/28 CHKD: JBELL 2017/03/14 APPR: FSMITH 2017/07/31	DESCRIPTION L1	QUALITY SYMBOLS	GENERAL TOLERANCES (UNLESS SPECIFIED)	DIMENSION STYLE	SCALE	DESIGN UNITS	THIRD ANGLE PROJECTION	
		$\nabla F=0$ $\nabla E=0$ $\nabla D=0$	mm INCH 4 PLACES ± --- ± --- 3 PLACES ± --- ± .010 2 PLACES ± .25 ± .010 1 PLACE ± .25 ± ---	MM/IN		METRIC		
			ANGULAR ± 3 °	DRAWN BY DATE H.HIRAMOTO 1991/03/12 CHECKED BY DATE S.KUNISHI 1998/07/07 APPROVED BY DATE FSMITH 2010/04/09	TITLE			
			DRAFT WHERE APPLICABLE MUST REMAIN WITHIN DIMENSIONS	MATERIAL NO. SEE CHART SIZE B	MOLEX INCORPORATED SD-5558****	DOCUMENT NO.		SHEET NO. 1 OF 2

10 9 8 7 6 5 4 3 2 1

REFLOWED MATTE TIN 0.00090/(.000035)
MIN. (PREPLATE) (FINISH IS BRIGHT IN APPEARANCE,
THICKNESS AS APPLIED PRIOR TO REFLOW)

PHOSPHOR
BRONZE

(0.9) .035	(4.5) .177	(3.6) .142	(0.6) .024	(2.7) .106	(2.3) .091	∅ (3.1) .122 MAX.	# 16
(0.6) .024	(2.3) .091	(2.3) .091	(0.4) .016	(1.65) .065	(1.8) .071	∅ (0.9-1.8) .035-.071	#22-28
(0.9) .035	(4.5) .177	(3.6) .142	(0.5) .020	(2.3) .091	(1.9) .075	∅ (1.3-3.1) .051-.122	#18-24

39-00-0084	5558 PBT3L	LOOSE
↑ -0083	↑ PBT3	CHAIN
-0068	PBT2L	LOOSE
-0067	PBT2	CHAIN
-0062	PBTL	LOOSE
-0061	PBT	CHAIN

REFLOWED MATTE TIN 0.00090/(.000035)
MIN OVER COPPER 0.00050/(.000020)
MIN. (PREPLATE) (FINISH IS BRIGHT IN APPEARANCE,
THICKNESS AS APPLIED PRIOR TO REFLOW)

BRASS

(0.9) .035	(4.5) .177	(3.6) .142	(0.6) .024	(2.7) .106	(2.3) .091	∅ (3.1) .122 MAX.	# 16
(0.6) .024	(2.3) .091	(2.3) .091	(0.4) .016	(1.65) .065	(1.8) .071	∅ (0.9-1.8) .035-.071	#22-28
(0.9) .035	(4.5) .177	(3.6) .142	(0.5) .020	(2.3) .091	(1.9) .075	∅ (1.3-3.1) .051-.122	#18-24

↑ -0082	T3L	LOOSE
↑ -0081	T3	CHAIN
-0049	T2L	LOOSE
-0048	T2	CHAIN
↓ -0041	↓ TL	LOOSE
39-00-0040	5558 T	CHAIN

PLATING MATERIAL F E D C B A INS. RANGE WIRE RANGE EDP NO. ENG. NO. FORM

SEE SHEET 1
EC NO: UCP2017-1893
DRAWN: GSLAFTER 2017/02/28
CHKD: JBELL 2017/03/14
APPR: FSMITH 2017/07/31

QUALITY SYMBOLS
▽=0
▽=0
▽=0

GENERAL TOLERANCES (UNLESS SPECIFIED)

	mm	INCH
4 PLACES	± ---	± ---
3 PLACES	± ---	± .010
2 PLACES	± .25	± .010
1 PLACE	± .25	± ---
ANGULAR ± 3 °		

DRAFT WHERE APPLICABLE
MUST REMAIN
WITHIN DIMENSIONS

DIMENSION STYLE MM/IN

DRAWN BY	DATE
H.HIRAMOTO	1991/03/12
CHECKED BY	DATE
S.KUNISHI	1998/07/07
APPROVED BY	DATE
FSMITH	2010/04/09

SCALE DESIGN UNITS METRIC

THIRD ANGLE PROJECTION

MINI-FIT JR
OVERALL TIN
MALE CRIMP TERMINAL

molex MOLEX INCORPORATED

MATERIAL NO. SEE CHART DOCUMENT NO. SD-5558**** SHEET NO. 2 OF 2

THIS DRAWING CONTAINS INFORMATION THAT IS PROPRIETARY TO MOLEX INCORPORATED AND SHOULD NOT BE USED WITHOUT WRITTEN PERMISSION