

Low Noise, Low Power Dissipation, 24/16-Bit Σ - Δ ADC

PRODUCT DESCRIPTION

The MS5194T/MS5195T is a 24-bit/16-bit ADC featured by low power dissipation, low noise, six differential input channels and it is suitable for high-precision measurement application.

The MS5194T/MS5195T integrates low noise input buffer, low noise instrumentation amplifier, internal bandgap reference with high precision, low noise and low drift, and it also could adopt external differential reference voltage. In addition, the MS5194T/MS5195T also integrates programmable excitation current source, burnout current source and bias voltage generator. The bias voltage generator could set the channel common-mode voltage to $0.5 \times AVDD$.

It adopts external or internal clock. The output data rate can be set from 4.17Hz to 470Hz by software. The power supply voltage ranges from 2.7V to 5.25V. The MS5194T/MS5195T is available in TSSOP24 package.



TSSOP24

FEATURES

- RMS Noise: MS5194T: 40nV@16.7Hz
- Power Dissipation: 400 μ A(typ)
- Integrated Low Noise, Programmable Gain Instrumentation Amplifier
- Integrated Voltage Reference with Low Temperature Drift : 5ppm/ $^{\circ}$ C
- Update Rate: 4.17Hz to 470Hz
- Integrated 50Hz/60Hz Rejection Filter
- Integrated Programmable Current Source
- Integrated Internal Clock Oscillator
- Integrated Internal Burnout Current, Excitation Current
- Integrated Bias Voltage Generator
- Power Supply Voltage: 2.7V to 5.25V
- Operating Temperature Range: -40 $^{\circ}$ C to 105 $^{\circ}$ C

APPLICATIONS

- Thermocouple and RTD Measurement
- Stress Detection
- Gas Analysis and Blood Analysis
- Industrial Process Control and Instrumentation
- Liquid and Gas Chromatograph
- 6-bit DVM

PRODUCT SPECIFICATION

Part Number	Package	Marking
MS5194T	TSSOP24	MS5194T
MS5195T	TSSOP24	MS5195T

PIN CONFIGURATION

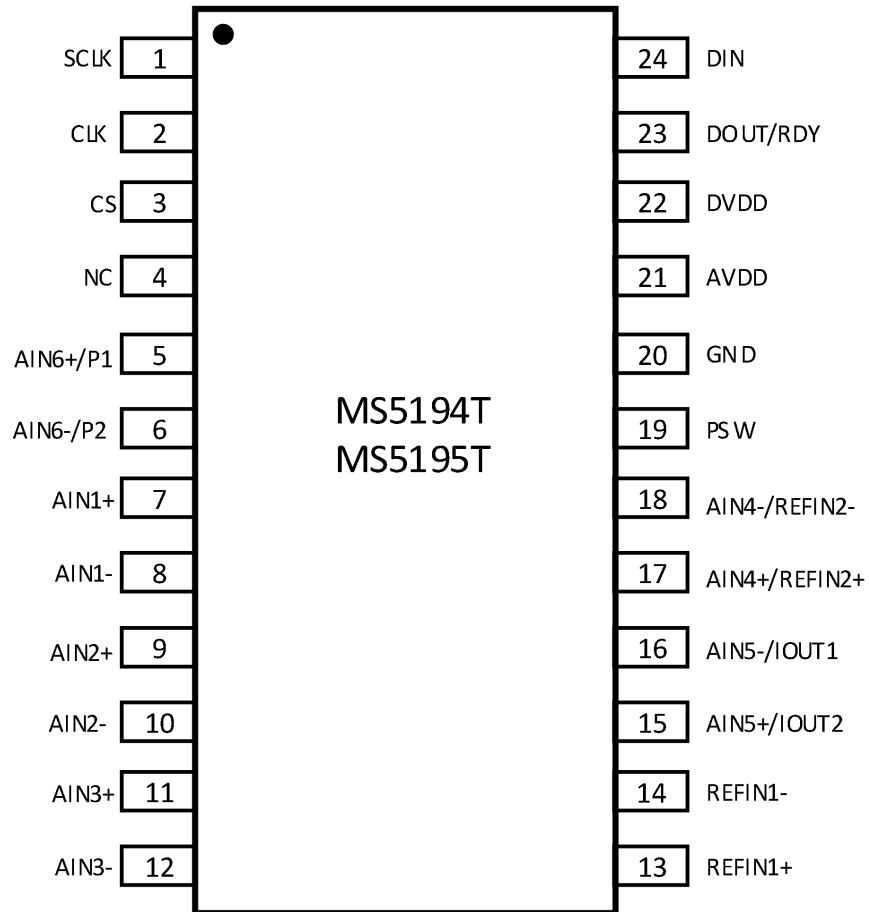

PIN DESCRIPTION

Pin	Name	Type	Description
1	SCLK	I	Serial Clock Input
2	CLK	I	Clock Input/Clock Output. Provide internal clock or Disable Internal Clock
3	CS	I	Chip Select Input
4	NC	-	Not Connection
5	AIN6+ /P1	I/O	Analog Channel 6 Positive Input/Digital Output Pin
6	AIN6- /P2	I/O	Analog Channel 6 Negative Input/Digital Output Pin
7	AIN1+	I	Analog Channel 1 Positive Input
8	AIN1-	I	Analog Channel 1 Negative Input
9	AIN2+	I	Analog Channel 2 Positive Input
10	AIN2-	I	Analog Channel 2 Negative Input
11	AIN3+	I	Analog Channel 3 Positive Input
12	AIN3-	I	Analog Channel 3 Negative Input
13	REFIN1+	I	Positive Reference Voltage 1 Input Pin
14	REFIN1-	I	Negative Reference Voltage 1 Input Pin
15	AIN5+ /IOUT2	IO	Internal Excitation Current Source Output Pin. The pin could be as positive input pin for analog channel 5.
16	AIN5- /IOUT1	IO	Internal Excitation Current Source Output Pin. The pin could be as negative input pin for analog channel 5.
17	AIN4+ /REFIN2+	I	Positive Reference Voltage 2 Input Pin. The pin could be as positive input pin for analog channel 4.
18	AIN4- /REFIN2-	I	Negative Reference Voltage 2 Input Pin. The pin could be as negative input pin for analog channel 4.
19	PSW	I	Low-Side Power Switch to GND
20	GND	-	Ground
21	AVDD	-	Analog Power Supply Voltage (2.7V to 5.25V)
22	DVDD	-	Digital Interface Power Pin. 2.7V to 5.25V
23	DOUT/RDY	O	Serial Data Output/Data Ready Output Pin
24	DIN	I	Serial Data Input

BLOCK DIAGRAM

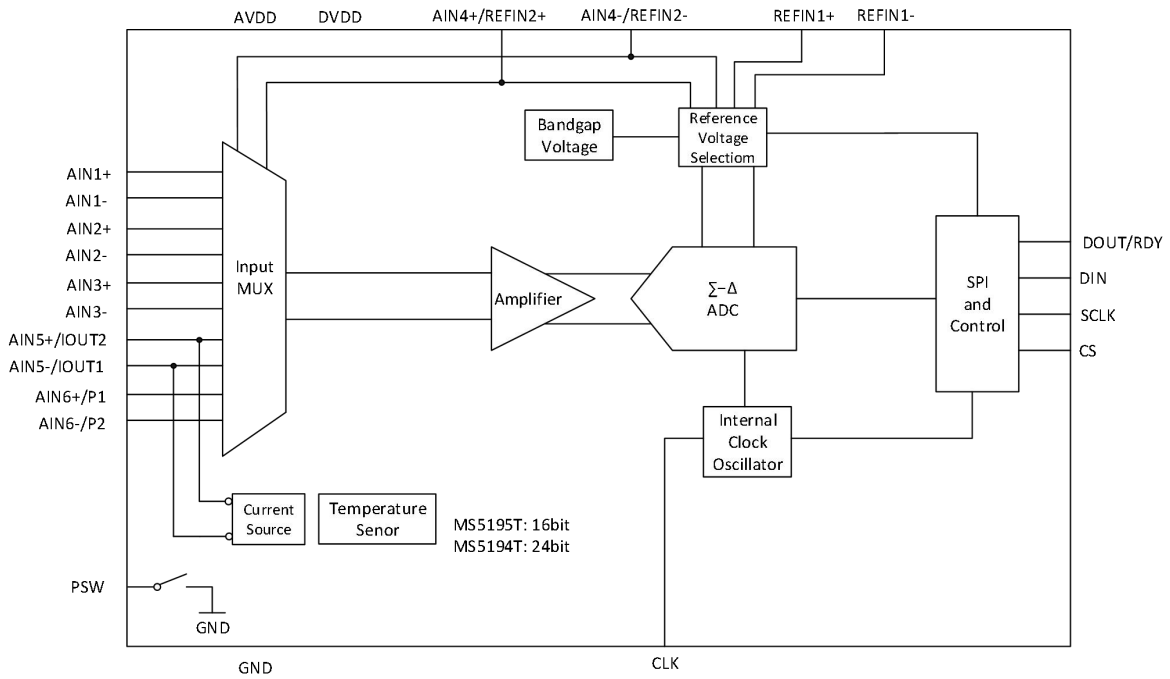

ABSOLUTE MAXIMUM RATINGS

Any exceeding absolute maximum rating application causes permanent damage to device. Because long-time absolute operation state affects device reliability. Absolute ratings just conclude from a series of extreme tests. It doesn't represent chip can operate normally in these extreme conditions.

Parameter	Symbol	Range	Unit
Analog Power Supply	AVDD	-0.3 ~ +7.0	V
Digital Power Supply	DVDD	-0.3 ~ +7.0	V
Analog Input Voltage	AIN	-0.3 ~ AVDD+0.3	V
Reference Voltage	VREFIN	-0.3 ~ AVDD+0.3	V
Digital Input Voltage		-0.3~ DVDD+0.3	V
Digital Output Voltage	V(LE)	-0.3 ~ DVDD+0.3	V
Input Port Current		10	mA
Operating Temperature		-40 ~ 105	°C
Storage Temperature	T _{stg}	-60 ~ 150	°C
Lead Temperature (10 sec)		260	°C
ESD (HBM)		4000	V

ELECTRICAL CHARACTERISTICS

AVDD=2.7V to 5.25V, DVDD=2.7V to 5.25V, GND=0V.

Unless otherwise noted, parameters are in whole temperature range.

Parameter	Condition	Min	Typ	Max	Unit
ADC Channel (Chopping Enable)					
Output Rate			4.17-470		Hz
No Missing Codes Accuracy			24/16		Bits
Resolution	See "Output Noise and Resolution"				
Output Noise and Rate	See "Output Noise and Resolution"				
Integral Nonlinearity				±15	ppm of FSR
Offset Error			±1		μV
Offset Error Temperature Drift			±10		nV/°C
Full-Scale Error			±10		μV
Gain Temperature Drift			1		ppm/°C
Power Supply Rejection	AIN=1V/gain, gain>4	100			dB
Analog Input					
Differential Input Voltage Range			±VREF/gain		V
Common-Mode Voltage	VCM= (AINP + AINN)/2, Gain = 4 to128	0.5			V
Analog Input Voltage	Disable Input Buffer, Gain=1 or 2	GND- 30mV		AVDD+ 30mV	V
	Enable Input Buffer, Gain=1 or 2	GND+ 100mV		AVDD- 100mV	V
	Enable Input Instrumentation Amplifier, Gain=4 to 128	GND+ 300mV		AVDD- 1.1	V
Analog Input Current When Buffered Mode or Enable Internal Instrumentation Amplifier	Gain = 1 or 2, Update Rate< 100 Hz			±1	nA
	Gain = 4 to 128, Update Rate< 100 Hz			±250	pA
	AIN3(+)/AIN3(-), Update Rate< 100 Hz			±1	nA

Parameter	Condition	Min	Typ	Max	Unit
Analog Input Current Temperature Drift When Buffered Mode or Enable Internal Instrumentation Amplifier			±2		pA/°C
Analog Input Current Relative to Voltage When Disable Input Buffer			±400		nA/V
Analog Input Current Temperature Drift When Disable Input Buffer			±50		pA/V/°C
Common-mode Rejection	DC, AIN = 1 V/gain, Gain ≥ 4	100			dB
	50 ± 1 Hz, 60 ± 1 Hz (FS[3:0] = 1010)	100			dB
	50 ± 1 Hz (FS[3:0] = 1001), 60 ± 1 Hz (FS[3:0] = 1000)	100			dB
Internal Reference Voltage					
Initial Resolution			1.17± 0.01%		V
Temperature Drift			4	15	ppm/°C
External Reference Voltage					
Reference Voltage		0.1	2.5	AVDD	V
Average Current, Reference Voltage Input			400		nA/V
Average Current Temperature Drift, Reference Voltage Input			±0.03		nA/V/°C
Common-mode Rejection			100		dB
Detection Level, Reference Voltage		0.3		0.65	V
Excitation Current Source (IEXC1, IEXC2)					
Output Current			10/210/1000		μA
Initial Tolerance			±5		%
Temperature Drift			200		ppm/°C
Current Match			±0.5		%

Parameter	Condition	Min	Typ	Max	Unit
Temperature Drift Match			50		ppm/°C
Voltage Regulation			2		%/V
Load Regulation			0.2		%/V
Output Voltage	Output Current 10μA,210μA	GND-30mV		AVDD-0.65	V
	Output Current 1mA	GND-30mV		AVDD-1.1	V
Temperature Sensor					
Accuracy			±2		°C
Sensitivity			0.85		mV/°C
Bias Voltage Generator					
Bias Voltage			AVDD/2		V
Low-side Power Switch					
On-resistance			7	9	Ω
Allowable Current				30	mA
Clock					
Internal Clock Frequency			64±3%		kHz
Internal Clock Duty Cycle			50:50		%
External Clock Frequency			64		kHz
External Clock Duty Cycle		45:55		55:45	%
Logic Input					
CS Input Low Voltage	DVDD=5V			0.8	V
	DVDD=3V			0.4	V
CS Input High Voltage		2.0			V
SCLK and DIN Input High-level Threshold	DVDD=5V	1.4		2	V
	DVDD=3V	0.9		2	V
SCLK and DIN Input Low-level Threshold	DVDD=5V	0.8		1.7	V
	DVDD=3V	0.4		1.35	V
SCLK and DIN Input Hysteresis	DVDD=5V	0.1		0.17	V
	DVDD=3V	0.06		0.13	V
Input Current				±10	μA
Input Capacitance			10		pF

Parameter	Condition	Min	Typ	Max	Unit	
Digital Logic Output						
Output High-level Voltage	AVDD=3 V, ISOURCE=100 μ A	DVDD-0.6			V	
	AVDD=5 V, ISOURCE=200 μ A	4			V	
Output Low-level Voltage	AVDD=3 V, ISINK=100 μ A			0.4	V	
	AVDD=5 V, ISINK=1.6mA			0.4	V	
Leakage Current, Floating-State				\pm 10	μ A	
Output Capacitance, Floating-State			10		pF	
System Calibration						
Full-Scale Calibration				1.05 \times FS	V	
Zero-Scale Calibration		-1.05 \times FS		1.05 \times FS	V	
Power Dissipation						
Power Supply Voltage	AVDD	2.7		5.25	V	
	DVDD	2.7		5.25	V	
Power Supply Current	AVDD=3V	Disable Input Buffer,		110	140	μ A
	AVDD=5V	External Reference		125	140	
	AVDD=3V	Enable Input Buffer, Gain= 1		130	180	μ A
	AVDD=5V	or 2, External Reference		165	180	
	AVDD=3V	Gain= 4 to 128,		300	400	μ A
	AVDD=5V	External Reference		350	400	μ A
	AVDD=3V	Gain= 4 to 128,		380	500	μ A
	AVDD=5V	Internal Reference		440	500	μ A
Shut-down Current				1	μ A	

OUTPUT NOISE and RESOLUTION (EXTERNAL REFERENCE)

The table below gives the output RMS noise for the MS5194T with some update rates and gain settings. These data are for bipolar input range and 2.5V external reference voltage source. These values are typical when the differential input voltage is 0V. It is important to note that the effective resolution is calculated from root mean square noise. These data are typical values rounded to the nearest LSB.

 Table 1. Output RMS Noise (μ V) VS. Gain and Update Rate for the MS5194T (External 2.5V Reference Voltage)

Update Rate	Gain=1	Gain=2	Gain=4	Gain=8	Gain=16	Gain=32	Gain=64	Gain=128
4.17Hz	0.532	0.469	0.306	0.240	0.133	0.078	0.044	0.046
8.33Hz	0.856	0.664	0.415	0.264	0.191	0.088	0.415	0.063
16.7Hz	1.436	1.142	0.643	0.422	0.254	0.152	0.111	0.119
33.2Hz	1.978	1.871	0.776	0.474	0.325	0.214	0.151	0.150
62Hz	2.683	2.615	1.315	0.690	0.547	0.272	0.256	0.221
123Hz	4.101	3.580	1.735	0.979	0.507	0.294	0.210	0.240
242Hz	7.277	6.283	3.108	1.929	1.147	0.777	0.449	0.441
470Hz	8.343	8.739	3.337	2.073	1.337	0.891	0.586	0.589

Table 2. Effective Resolution (Bits) VS. Gain and Update Rate for the MS5194T (External 2.5V Reference Voltage)

Update Rate	Gain=1	Gain=2	Gain=4	Gain=8	Gain=16	Gain=32	Gain=64	Gain=128
4.17Hz	23(20.5)	22(19.5)	22.5(20)	22.5(20)	22(19.5)	22(19.5)	21.5(19)	20.5(18)
8.33Hz	22(19.5)	21.5(19)	22(19.5)	22(19.5)	21.5(19)	21.5(19)	21(18.5)	20(17.5)
16.7Hz	21.5(19)	20.5(18)	21.5(19)	21(18.5)	21(18.5)	21(18.5)	20(17.5)	19(16.5)
33.2Hz	21(18.5)	20(17.5)	21(18.5)	20.5(18)	20.5(18)	20.5(18)	19.5(17)	18.5(16)
62Hz	20.5(18)	19.5(17)	20.5(18)	20(17.5)	19.5(17)	19.5(17)	19(16.5)	18(15.5)
123Hz	20(17.5)	19(16.5)	20(17.5v)	19.5(17)	19(16.5v)	19(16.5)	18.5(16)	17.5(15)
242Hz	18.5(16)	18(15.5)	18.5(16)	18(15.5)	18(15.5)	18.5(16)	18(15.5)	17(14.5)
470Hz	18.5(16)	18(15.5)	18.5(16)	18(15.5)	18(15.5)	18.5(16)	17.5(15)	16.5(14)

OUTPUT NOISE and RESOLUTION (INTERNAL REFERENCE)

The table below gives the output RMS noise for the MS5194T with some update rates and gain settings. These data are for bipolar input range and 1.17V internal reference voltage source. These values are typical when the differential input voltage is 0V. It is important to note that the effective resolution is calculated from root mean square noise. These data are typical values rounded to the nearest LSB.

 Table 3. Output RMS Noise (μV) VS. Gain and Update Rate for the MS5194T (Internal Reference Voltage)

Update Rate	Gain=1	Gain=2	Gain=4	Gain=8	Gain=16	Gain=32	Gain=64	Gain=128
4.17Hz	0.614	0.486	0.289	0.194	0.109	0.069	0.045	0.046
8.33Hz	0.827	0.795	0.342	0.243	0.173	0.081	0.342	0.064
16.7Hz	1.179	1.138	0.572	0.322	0.249	0.130	0.100	0.099
33.2Hz	2.244	1.771	0.827	0.443	0.325	0.178	0.129	0.131
62Hz	3.180	2.663	0.990	0.684	0.487	0.248	0.184	0.215
123Hz	5.019	3.648	1.704	1.018	0.759	0.376	0.272	0.262
242Hz	7.274	7.896	2.762	1.527	0.868	0.555	0.409	0.390
470Hz	9.078	8.366	3.210	2.140	1.330	0.763	0.705	0.503

Table 4. Effective Resolution (Bits) VS. Gain and Update Rate for the MS5194T (Internal Reference Voltage)

Update Rate	Gain=1	Gain=2	Gain=4	Gain=8	Gain=16	Gain=32	Gain=64	Gain=128
4.17Hz	21.6	20.9	20.7	20.2	20.1	19.7	19.3	18.3
8.33Hz	21.1	20.2	20.4	19.9	19.4	19.5	16.4	17.8
16.7Hz	20.6	19.7	19.7	19.5	18.9	18.8	18.2	17.2
33.2Hz	19.7	19.0	19.1	19.0	18.5	18.4	17.8	16.8
62Hz	19.2	18.5	18.9	18.4	17.9	17.9	17.3	16.1
123Hz	18.5	18.0	18.1	17.8	17.3	17.3	16.7	15.8
242Hz	18.0	16.9	17.4	17.3	17.1	16.7	16.2	15.2
470Hz	17.7	16.8	17.2	16.8	16.5	16.3	15.4	14.9

TYPICAL CHARACTERISTICS CURVES

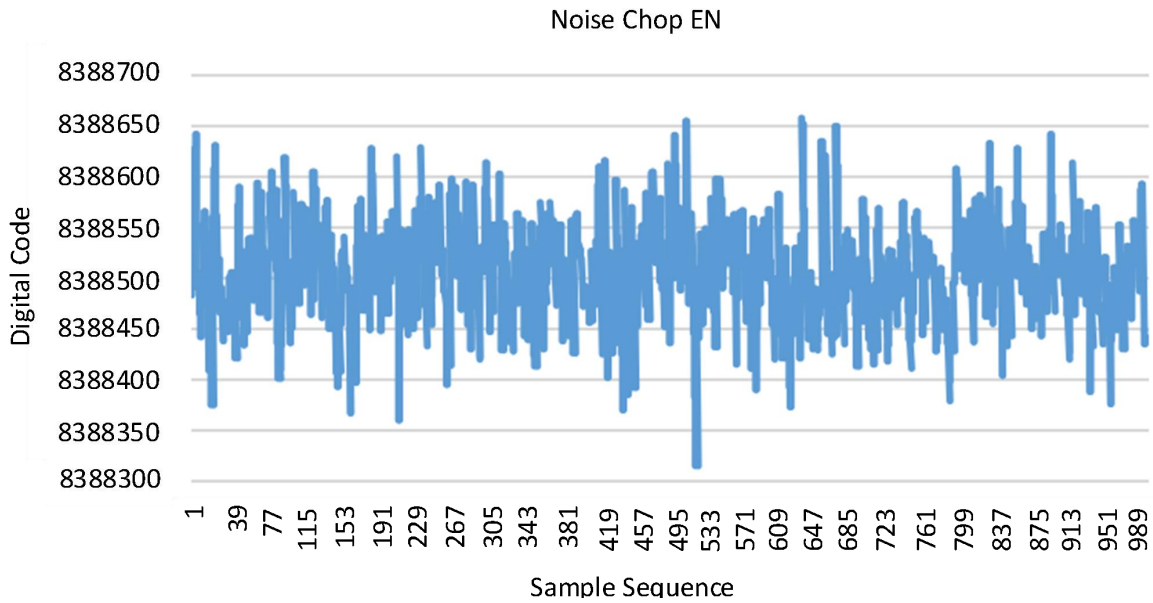

MS5194T Noise (AVDD=4V, Internal Reference, Gain = 64, Update Rate= 16.7 Hz, Chop Enable)

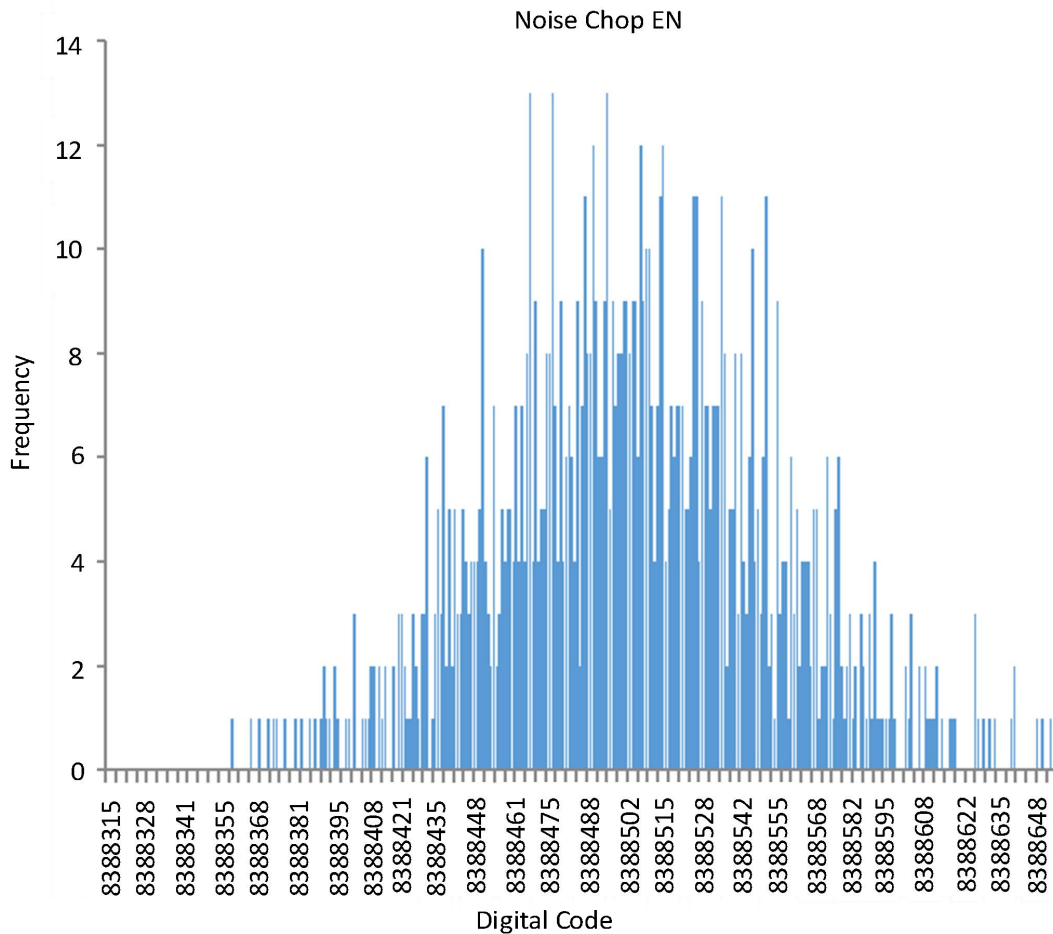

MS5194T Noise Distribution Histogram
(AVDD=4V, Internal Reference, Gain= 64, Update Rate= 16.7Hz, Chop Enable)

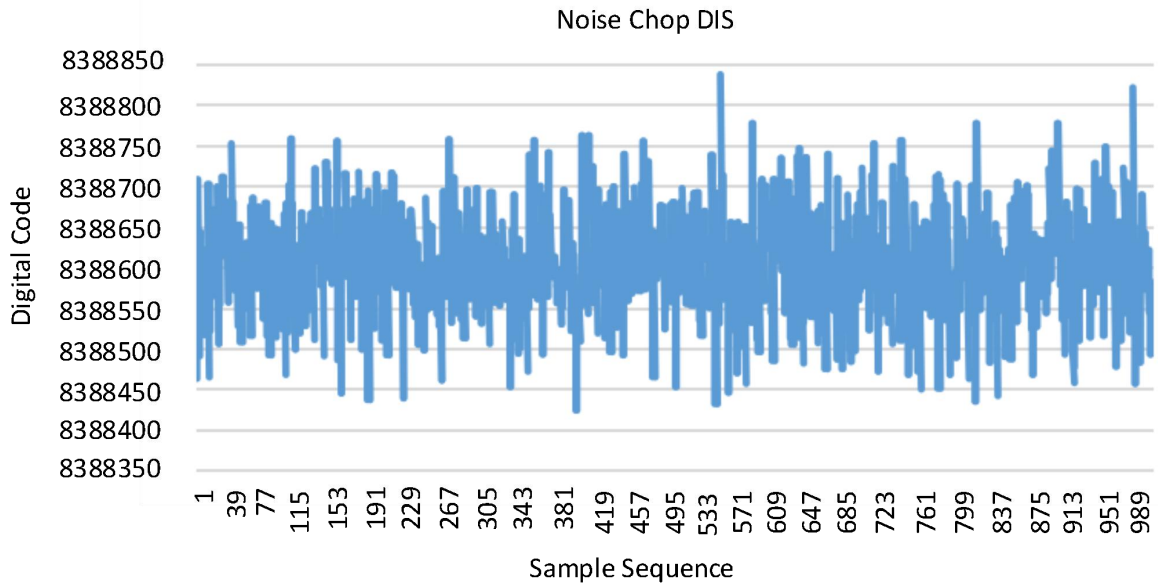

MS5194TNoise (AVDD=4V, Internal Reference, Gain=64, Update Rate= 16.7Hz, Chop Disable)

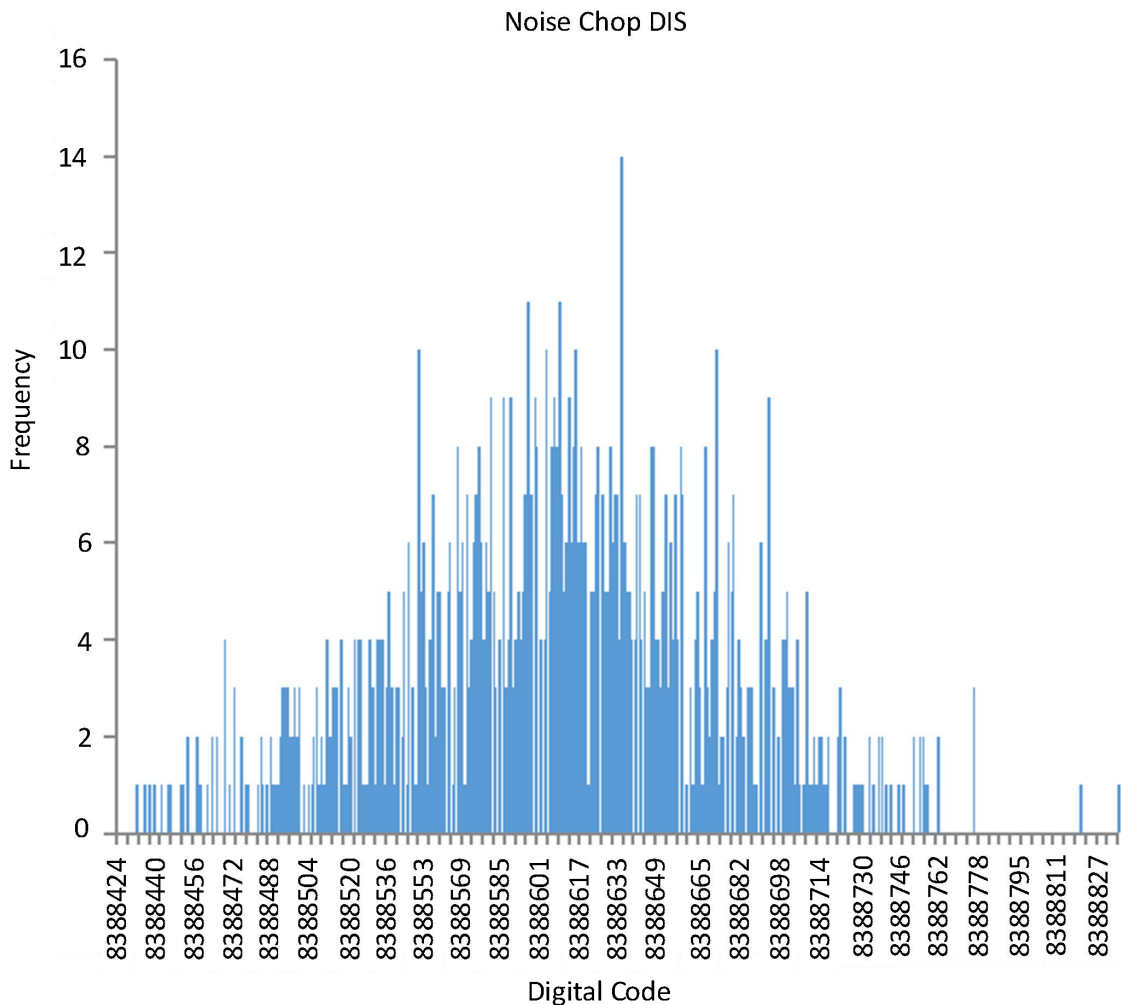

MS5194T Noise Distribution Histogram
(AVDD=4V, Internal Reference= 2.048, Gain=64, Update Rate= 4.17 Hz, Chop Disable)

TYPICAL APPLICATION DIAGRAM

The figure is a typical application diagram for the MS5194T/MS5195T.

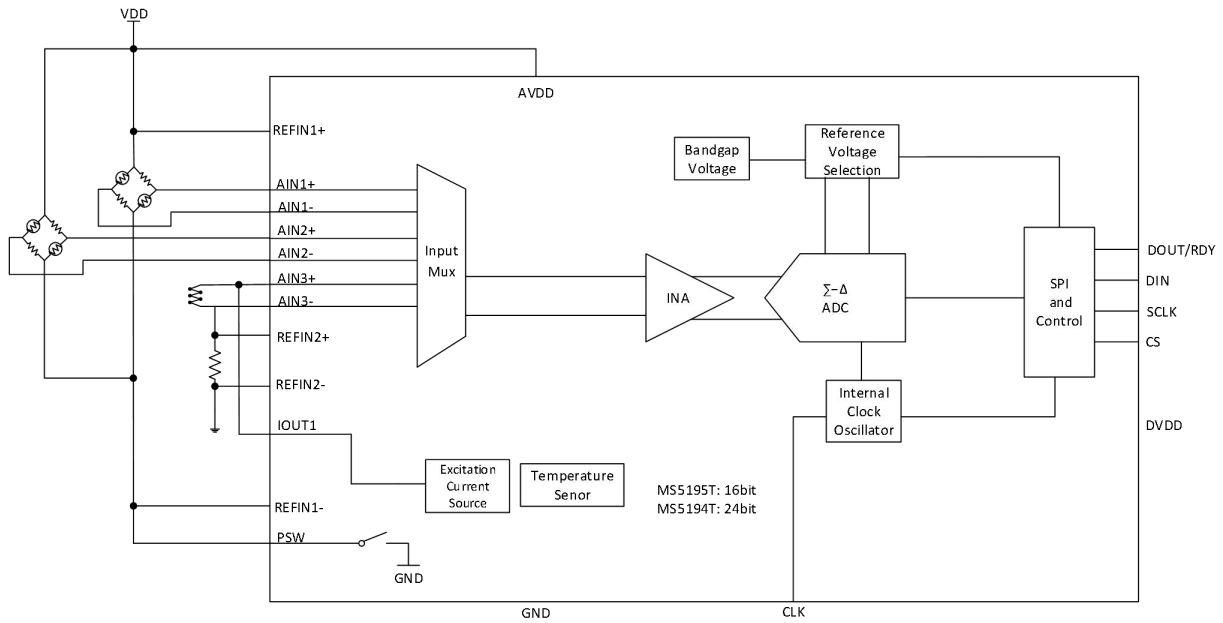

PACKAGE OUTLINE DIMENSIONS

TSSOP24

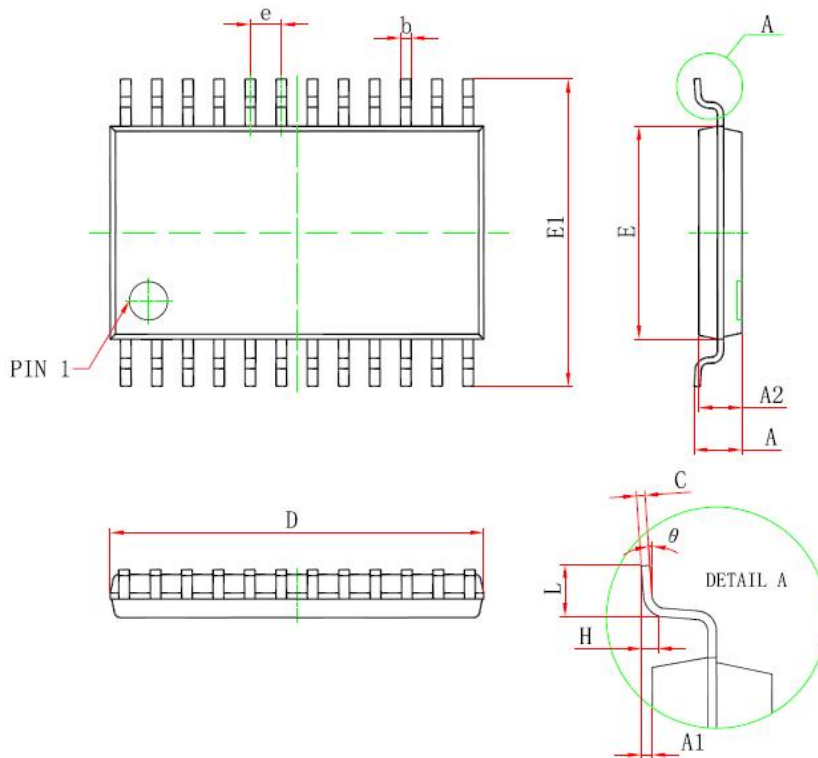

Symbol	Dimensions in Millimeters	
	Min	Max
D	7.700	7.900
E	4.300	4.500
b	0.190	0.300
c	0.090	0.200
E1	6.250	6.550
A	-	1.20
A2	0.800	1.000
A1	0.050	0.150
e	0.65(BSC)	
L	0.500	0.700
H	0.25(TYP)	
θ	1°	7°

MARKING and PACKAGING SPECIFICATIONS

1. Marking Drawing Description

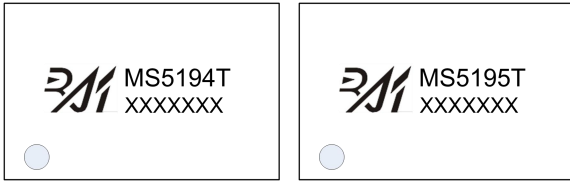

Product Name: MS5194T, MS5195T

Product Code: XXXXXXX

2. Marking Drawing Demand

Laser printing, contents in the middle, font type Arial.

3. Packaging Specifications

Device	Package	Piece/Reel	Reel/Box	Piece/Box	Box/Carton	Piece/Carton
MS5194T	TSSOP24	3000	1	3000	8	24000
MS5195T	TSSOP24	3000	1	3000	8	24000

STATEMENT

- All Revision Rights of Datasheets Reserved for Ruimeng. Don't release additional notice.
Customer should get latest version information and verify the integrity before placing order.
- When using Ruimeng products to design and produce, purchaser has the responsibility to observe safety standard and adopt corresponding precautions, in order to avoid personal injury and property loss caused by potential failure risk.
- The process of improving product is endless. And our company would sincerely provide more excellent product for customer.

**MOS CIRCUIT OPERATION PRECAUTIONS**

Static electricity can be generated in many places. The following precautions can be taken to effectively prevent the damage of MOS circuit caused by electrostatic discharge:

1. The operator shall ground through the anti-static wristband.
2. The equipment shell must be grounded.
3. The tools used in the assembly process must be grounded.
4. Must use conductor packaging or anti-static materials packaging or transportation.



+86-571-89966911



Rm701, No.9Building, No. 1 WeiYe Road, Puyan Street, Binjiang District, Hangzhou, Zhejiang



http:// www.relmon.com