



# DEGSON ELECTRONICS CO., LTD.

## Product Specification



**15EDGKNM-3.5**

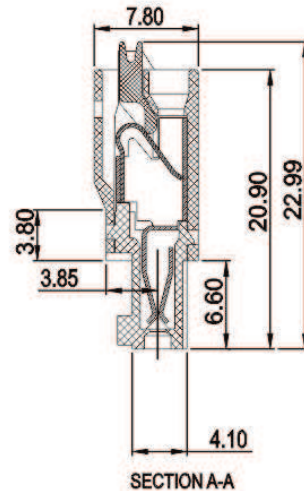
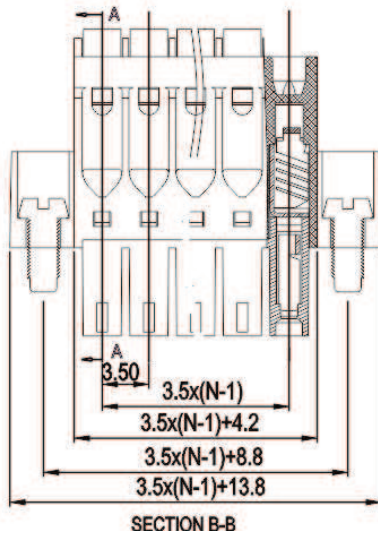
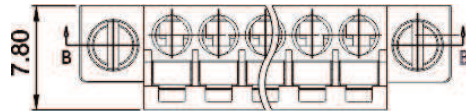

<b>APPROVAL</b>		
<b>Electrical</b>	<b>UL</b>	<b>IEC</b>
Standard	300V	250V
Rated voltage	8A	8A
Rated current	28-16AWG	0.2-1.0mm <sup>2</sup>
Wire range	2.5KV	
Rated impulse voltage		
<b>Mechanical</b>		
Ambient temperature	-40°C~+105°C	
Strip length	10mm	
<b>Dimensions</b>		
Pitch	3.5mm(.138" ) 3.81mm(.150" )	
Poles	2P-20P	
<b>Material</b>		
Housing	PA66,UL94 V-0	
Contact	Phosphor bronze	
Wire guard	Stainless steel	

### HOW TO ORDER :

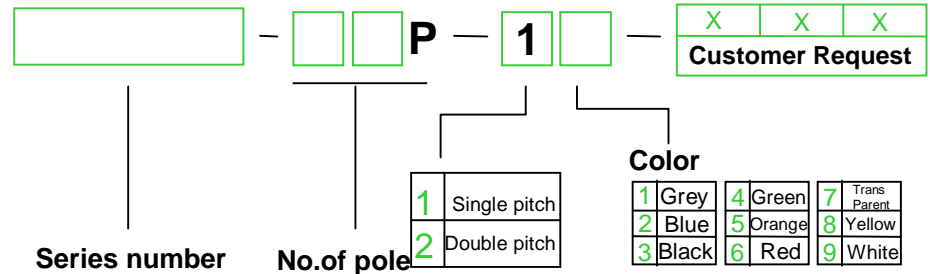

 mm (INCH)	 <b>DEGSON ELECTRONICS CO., LTD.</b>
 THROANGLE PROJECTION	<b>NAME</b> <b>15EDGKNM-3.5</b>