

## Features

- ◇ For surface mounted application
- ◇ Easy pick and place
- ◇ Low forward voltage drop
- ◇ High current capability
- ◇ High surge current capability
- ◇ High temperature soldering guaranteed:  
260°C / 10 seconds at terminals
- ◇ Plastic material used carriers Underwriters  
Laboratory Classification 94V-0

## GS2A-GS2M

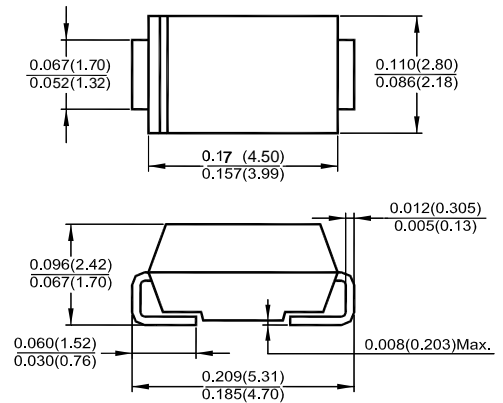

Dimensions in inches and (millimeters)  
DO-214AC (SMA)

## Mechanical Data

- ◇ Case: JEDEC DO-214AA, molded plastic body over passivated chip
- ◇ Polarity: Color band denotes cathode end

## MAXIMUM RATINGS AND ELECTRICAL CHARACTERISTICS

Ratings at 25 °C ambient temperature unless otherwise specified. Single phase, half wave, 60 Hz, resistive or inductive load. For capacitive load, derate current by 20%.

Type Number	Symbol	GS2A	GS2B	GS2D	GS2G	GS2J	GS2K	GS2M	Units
Maximum Recurrent Peak Reverse Voltage	$V_{RRM}$	50	100	200	400	600	800	1000	V
Maximum RMS Voltage	$V_{RMS}$	35	70	140	280	420	560	700	V
Maximum DC Blocking Voltage	$V_{DC}$	50	100	200	400	600	800	1000	V
Maximum Average Forward Rectified Current @Ta(See Fig. 1)	$I_{(AV)}$	2.0							A
Peak Forward Surge Current, 8.3 ms Single Half Sine-wave Superimposed on Rated Load (JEDEC method )	$I_{FSM}$	60							A
Maximum Instantaneous Forward Voltage (Note 1) $I_F = 2.0A @ Ta = 25^\circ C$	$V_F$	1.1							V
Maximum DC Reverse Current @ Ta=25°C @ Ta=125°C	$I_R$	5.0 50.0							uA
Typical Junction Capacitance(Note 3)	$C_j$	30							pF
Typical Thermal Resistance (Note 2)	$R_{\theta JA}$ $R_{\theta JL}$	80 28							°C/W
Operating Temperature Range	$T_J$	-55 to +150							°C
Storage Temperature Range	$T_{STG}$	-55 to +150							°C

Notes: 1. Pulse Test with PW=300u sec, 1% Duty Cycle.

2. Mount on Cu-Pad Size 5mm x 5mm on P.C.B.

3. Measured at f=1.0MHz, VR= 4.0V D.C.

Typical Characteristics

**GS2A-GS2M**

