

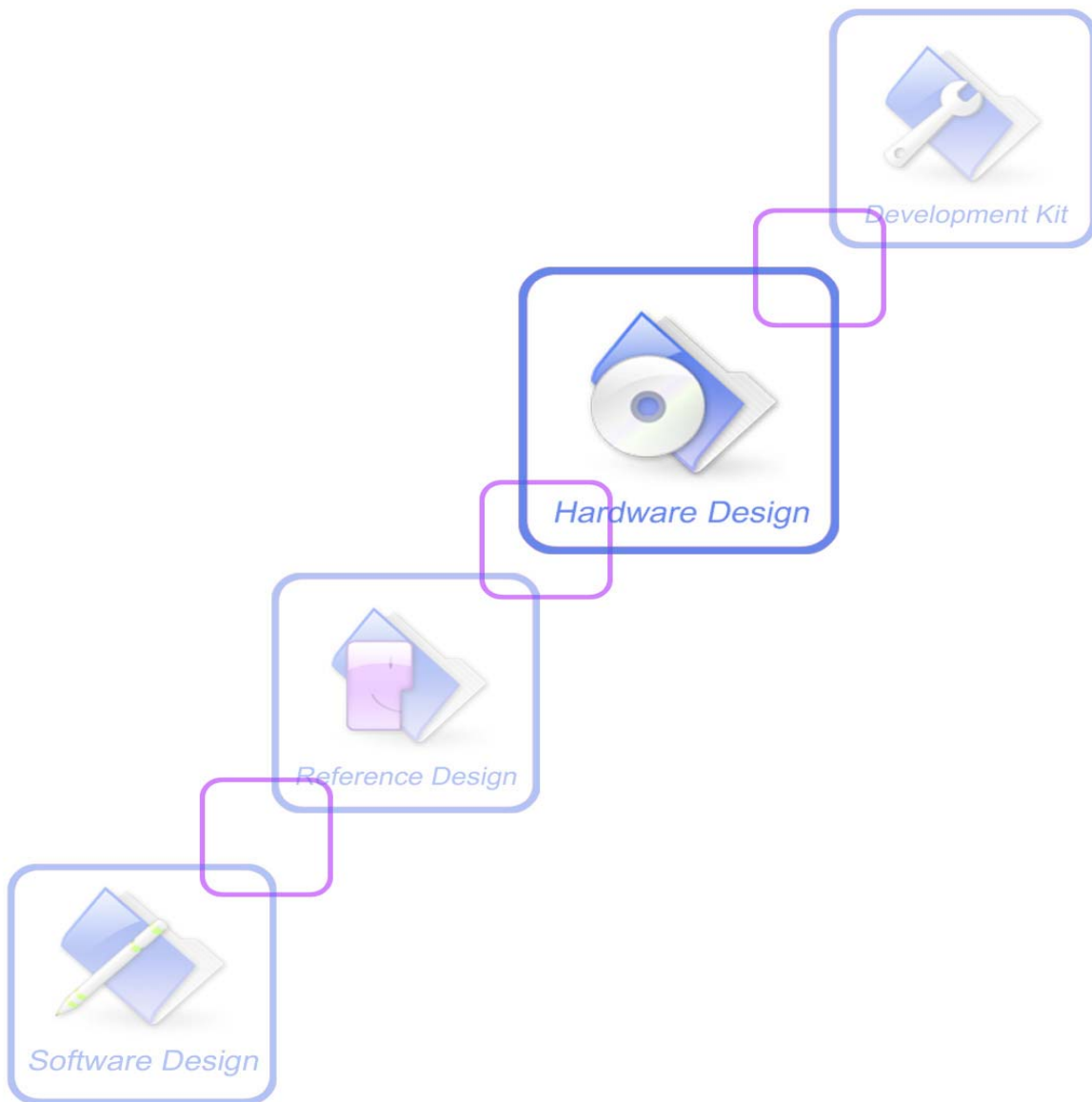

A company of SIM Tech

SIM68V_Hardware Design_V1.01



Document Title	SIM68V Hardware Design
Version	1.01
Date	2012-11-26
Status	Release
Document Control ID	SIM68V_Hardware Design_V1.01

General Notes

SIMCom offers this information as a service to its customers, to support application and engineering efforts that use the products designed by SIMCom. The information provided is based upon requirements specifically provided to SIMCom by the customers. SIMCom has not undertaken any independent search for additional relevant information, including any information that may be in the customer's possession. Furthermore, system validation of this product designed by SIMCom within a larger electronic system remains the responsibility of the customer or the customer's system integrator. All specifications supplied herein are subject to change.

Copyright

This document contains proprietary technical information which is the property of SIMCom Limited, copying of this document and giving it to others and the using or communication of the contents thereof, are forbidden without express authority. Offenders are liable to the payment of damages. All rights reserved in the event of grant of a patent or the registration of a utility model or design. All specification supplied herein are subject to change without notice at any time.

Copyright © Shanghai SIMCom Wireless Solutions Ltd. 2012

Contents

Contents	3
Version History	7
1 Introduction	8
2 SIM68V Overview	8
2.1 SIM68V Functional Diagram	9
2.2 GNSS Performance.....	9
2.3 General features.....	10
3 Package Information	11
3.1 Pin out Diagram.....	11
3.2 Pin Description	12
3.3 Package Dimensions.....	13
3.4 SIM68V Recommended PCB Decal.....	14
4 Application Interface	15
4.1 Power Management	15
4.1.1 Power Input.....	15
4.1.2 Starting SIM68V	15
4.1.3 Verification of SIM68V Start.....	15
4.1.4 Power Saving Modes.....	15
4.1.5 Operating Mode	16
4.1.5.1 Full on Mode.....	16
4.1.5.2 Sleep Mode	16
4.1.6 Operating Mode	16
4.2 UART Interface.....	16
4.3 SPI Interface	17
4.4 I ² C Interface.....	17
4.5 Timemark Output.....	17
4.6 A-GPS	18
4.6.1 EPO.....	18
4.6.2 EASY Mode.....	18
4.6.3 SBAS.....	18
4.7 Antenna.....	19
4.7.1 Antenna Interface.....	19
4.7.2 Antenna Choice Consideration.....	19
4.7.2.1 Passive Antenna	19
4.7.2.2 Active Antenna	21
5 Electrical, Reliability and Radio Characteristics	23
5.1 Absolute Maximum Ratings.....	23
5.2 Recommended Operating Conditions.....	23
5.3 Electro-Static Discharge	24
6 Manufacturing	25
6.1 Top and bottom View of SIM68V.....	25

6.2	Label information	25
6.3	Assembly and Soldering	26
6.4	Moisture sensitivity	27
6.5	ESD handling precautions	27
6.6	Shipment	28
7	Reference Design.....	28
Appendix	29
A.	Related Documents.....	29
B.	Terms and Abbreviations	29

SIMCOM CONFIDENTIAL FILE

Table Index

TABLE 1: GNSS PERFORMANCE	9
TABLE 2: GENERAL FEATURES	10
TABLE 3: PIN DESCRIPTION	12
TABLE 4: POWER SUPPLY AND CLOCK STATE ACCORDING TO OPERATION MODE.....	16
TABLE 5: HOST PORT MULTIPLEXED FUNCTION PINS	16
TABLE 6 : SPI FUNCTION PINS	17
TABLE 7: ANTENNA SPECIFICATIONS.....	19
TABLE 8: ABSOLUTE MAXIMUM RATINGS.....	23
TABLE 9: SIM68V OPERATING CONDITIONS	23
TABLE 10: SIM68V STANDARD IO FEATURES.....	23
TABLE 11: THE ESD CHARACTERISTICS (TEMPERATURE: 25°C, HUMIDITY: 45 %)	24
TABLE 12: ILLUSTRATION OF MODULE INFORMATION.....	26
TABLE 13: MOISTURE CLASSIFICATION LEVEL AND FLOOR LIFE	27
TABLE 14: RELATED DOCUMENTS	29
TABLE 15: TERMS AND ABBREVIATIONS.....	29

SIMCOM CONFIDENTIAL FILE

Figure Index

FIGURE 1: SIM68V FUNCTIONAL DIAGRAM.....	9
FIGURE 2: SIM68V PIN OUT DIAGRAM (TOP VIEW).....	11
FIGURE 3: SIM68V MECHANICAL DIMENSIONS (UNIT: MM).....	13
FIGURE 4: RECOMMENDED PCB DECAL (TOP VIEW) (UNIT: MM).....	14
FIGURE 5: TIMEMARK APPLICATION CIRCUIT.....	17
FIGURE 6: SIM68V PASSIVE ANTENNA DESIGN.....	20
FIGURE 7: SIM68V PASSIVE ANTENNA DESIGN (WITH EXTERNAL LNA AND SAW).....	20
FIGURE 8: SIM68V PASSIVE ANTENNA DESIGN FOR BEST PERFORMANCE AND INCREASED IMMUNITY.....	21
FIGURE 9: SIM68V ACTIVE ANTENNA DESIGN.....	21
FIGURE 10: TOP AND BOTTOM VIEW OF SIM68V.....	25
FIGURE 11: LABEL OF SIM68V.....	25
FIGURE 12: THE RAMP-SOAK-SPIKE REFLOW PROFILE OF SIM68V.....	26
FIGURE 13: EXAMPLE APPLICATION SCHEMATIC WITH UART.....	28

SIMCOM CONFIDENTIAL FILE

Version History

Date	Version	Description of change	Author
2012-08-13	V1.00	Origin	Ma Honggang
2012-11-26	V1.01	Add some features	Ma Honggang

SIMCOM CONFIDENTIAL FILE

1 Introduction

This document describes the hardware interface of the SIMCom module SIM68V, SIM68V is a GNSS All-in-one solution, which can be used as a stand alone or A-GPS (Assisted Global Positioning System), GLONASS and QZSS receiver. All functional components of SIM68V are described in great detail.

2 SIM68V Overview

SIM68V is a GNSS All-in-one module with stand-alone GPS (A-GPS supported) and GLONASS receiver, with built-in LNA, SIM68V can relax antenna requirement and don't need external LNA. SIM68V can track as low as -167dBm signal even without network assistance. The SIM68V has excellent low power consumption characteristic (acquisition 34mA, tracking 27mA). SIM68V supports various location and navigation applications, including autonomous GPS, GLONASS, SBAS ranging (WAAS, EGNOS, GAGAN and MSAS), QZSS, DGPS, and A-GPS.

Key Features

The module provides complete signal processing from antenna input to host port in NMEA messages. The module requires 2.8V to 4.3V power supply, which gives customers plenty of choices for the application circuit. The host port is configurable to UART. Host data and I/O signal levels are 2.8V CMOS compatible.

- GPS/GLONASS receiver, supports multi-GNSS include QZSS, SBAS ranging, supports WAAS/EGNOS/MSAS/GAGAN
- 33tracking/99 acquisition-channel GNSS receiver
- Small footprint: 16 x 12.2 x 2.4mm, 24-pin LCC package
- 12 multi-tone active interference cancellers and jamming elimination⁽¹⁾
- Indoor and outdoor multi-path detection and compensation
- Max fixed update rate up to 10 HZ⁽²⁾
- Advanced software features
 1. Always locate advanced location awareness technology
 2. EPO/HotStill orbit prediction
 3. EASY self-generated orbit prediction
- Pulse-per-second (PPS) GPS time reference
 1. Adjustable duty cycle
 2. typical accuracy: $\pm 10\text{ns}$
- Interface
 1. UART
 2. SPI/I2C⁽³⁾
- Operating temperature: -40 ~ +85°C
- Accuracy 2.5m CEP
- RoHS compliant

(1) AIC is default off and can be enabled by PMTK command. See *document [2]* for details.

(2) Default is 1 HZ.

(3) SPI and I2C can't be applied synchronous.

2.1 SIM68V Functional Diagram

The following figure shows a functional diagram of the SIM68V and illustrates the mainly functional parts:

- The main chip
- SAW filter
- The antenna interface
- The communication interface
- The control signals

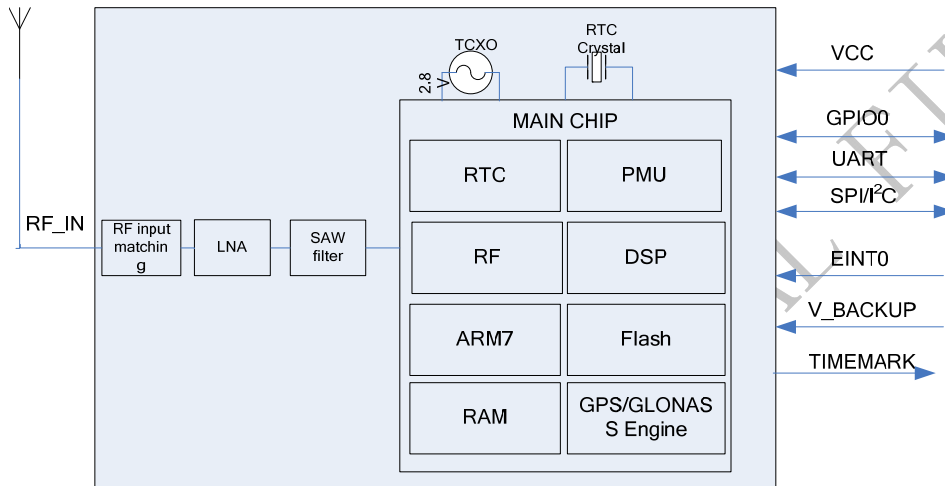

Figure 1: SIM68V functional diagram

2.2 GNSS Performance

Table 1: GNSS Performance

Parameter	Description	Performance			
		Min	Type	Max	Unit
Horizontal Position Accuracy(1)	Autonomous(2D-RMS)		3.0		m
	DGPS		2.5		
Velocity Accuracy(2)	Without Aid		0.1		m/s
	DGPS		0.05		m/s
Acceleration Accuracy	Without Aid		0.1		m/s ²
	DGPS		0.05		m/s ²
Timing Accuracy			<100		nS
Dynamic Performance	Maximum Altitude			18000	m
	Maximum Velocity			515	m/s
	Maximum Acceleration			4	G
Time To First Fix(3)	Hot start		<1		s
	Warm start		26		s
	Cold start		28		s

A-GPS TTFF(EPO in flash mode)	Hot start		<1		s
	Warm start		3.3		s
	Cold start		13.5		s
Sensitivity	Autonomous acquisition(cold start)		-148		dBm
	Re-acquisition		-160		dBm
	Tracking		-167		dBm
Receiver	Channels		33tracking/99 acquisition-channel		
	Update rate		1	10	Hz
	Tracking L1, CA Code				
	Protocol support NMEA,PMTK				
Power consumption(4)	Continuous tracking		30		mA
	Sleep current		340		uA

(1) 50% 24hr static, -130dBm

(2) 50% at 30m/s

(3) GPS signal level: -130dBm; GLONASS signal level: -130dBm

(4) Single Power supply 3V

2.3 General features

Table 2: General features

Parameters		Value
Supply voltage VCC		+2.8V~4.3V
Supply voltage ripple VCC		54 mV(RMS) max @ f = 0~3MHz 15 mV(RMS) max @ f > 3 MHz
Power consumption(acquisition)		34mA type. @ VCC=3 V
Power consumption(sleep)		340uA type. @ VCC=3 V
Storage temperature		-40°C~+85°C
Operating temperature		-40°C~+85°C (note 1)
I/O signal levels	VIL	-0.3V~0.8V
	VIH	2.0V~3.6V
	VOL	-0.3V~0.4V
	VOH	2.4V~3.1V
I/O output sink/source capability		+/- 3mA max
I/O input leakage		+/- 10 uA max
Host port		UART
Other port		I2C/SPI
Serial port protocol (UART)		NMEA; 8 bits, no parity, 1 stop bit; 115200 baud (configurable)
TM output (1PPS)		1 pulse per second, synchronized at rising edge, pulse length 300ms

Note 1: Operation in the temperature range -40°C ~ -30°C is allowed but Time-to-First-Fix performance and tracking sensitivity may be degraded.

3 Package Information

3.1 Pin out Diagram

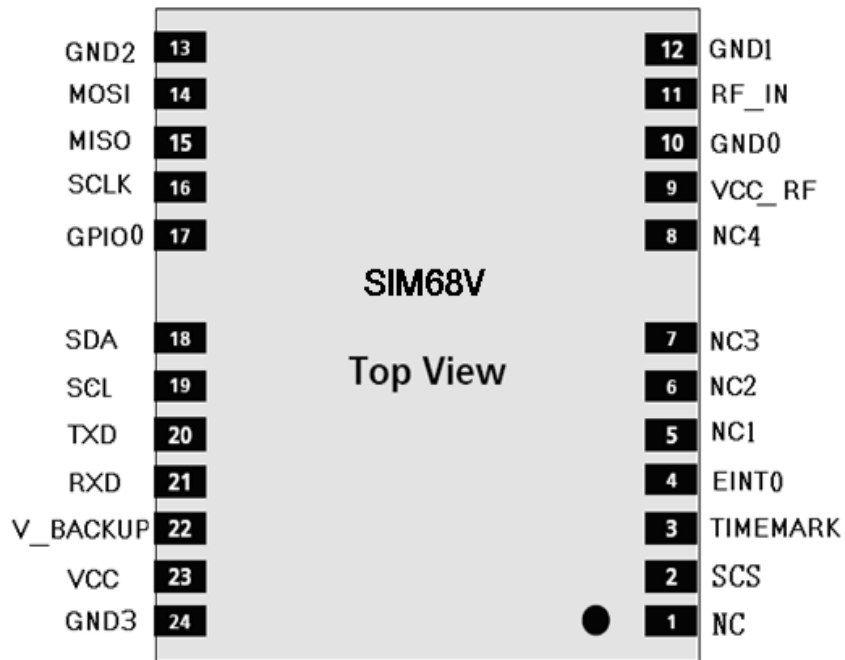

Figure 2: SIM68V pin out diagram (Top view)

3.2 Pin Description

Table 3: Pin description

Pin name	Pin number	I/O	Description	Comment
Power supply				
VCC	23	I	Main power input, which will be used to power the baseband and RF section internally.	Provide clean and stable power source to this pin. Add a 4.7uF capacitor to this pin for decoupling.
VCC_RF	9	O	2.8V output power supply for active antenna	If unused, keep open.
V_BACKUP	22	I/O	The backup battery input power supply for RTC	If unused, keep open.
GND	10,12,13,24		Ground	GND
Host port interface				
MISO	15	I	SPI MISO	If unused, keep open.
MOSI	14	O	SPI MOSI	
SCLK	16	O	SPI clock	
SCS	2	O	SPI slave select	
SDA	18	I/O	I ² C data	If unused, keep open.
SCL	19	I/O	I ² C Clock	
TXD	20	O	Serial output	
RXD	21	I	Serial input	
GPIOs				
EINT0	4	I	This interrupt source could act as wake up event during power saving mode. Provide an interrupt on either high or low logic level or edge-sensitive interrupt	If unused, keep open.
TIMEMARK	3	O	Time Mark outputs timing pulse related to receiver time	If unused, keep open.
GPIO0	17	I/O	GPIO can provide the developers signal or message outputs. GPIO lines support a simple control interface.	If unused, keep open.
RF interface				
RF_IN	11	I	Radio antenna connection	Impedence must be controlled to 50Ω.
Other interface				
NC	1,5,6,7,8		Not Connected	Keep floating

3.3 Package Dimensions

Following figure shows the Mechanical dimensions of SIM68V (top view, side view and bottom view).

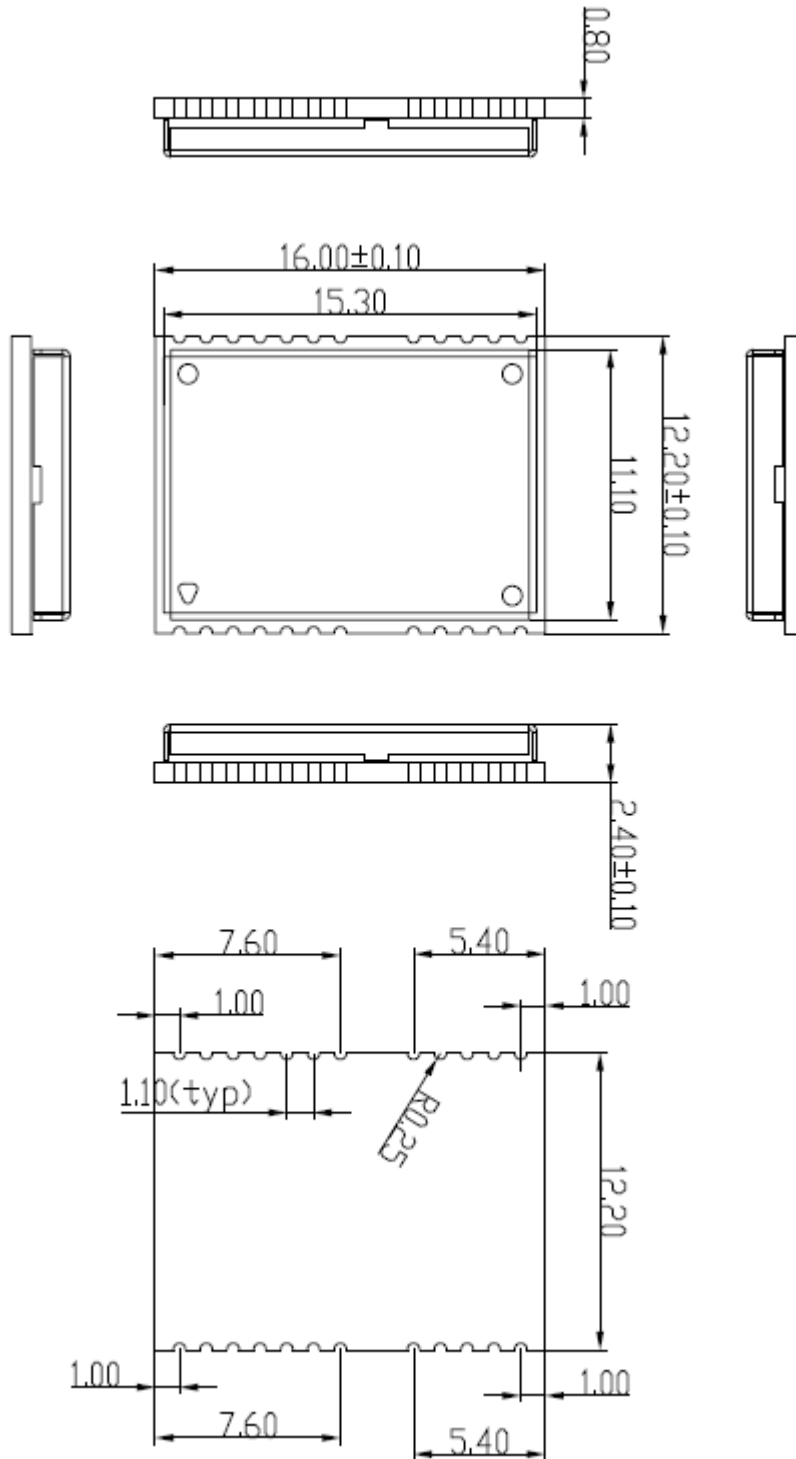

Figure 3: SIM68V mechanical dimensions (Unit: mm)

3.4 SIM68V Recommended PCB Decal

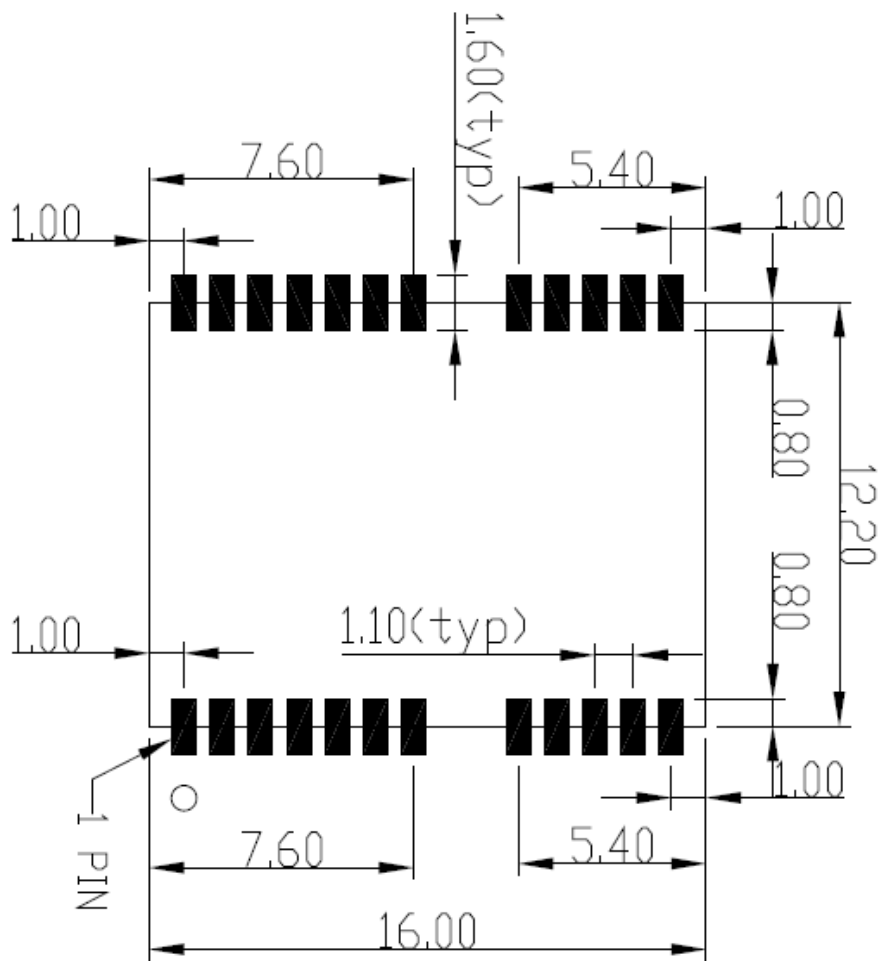

Figure 4: Recommended PCB decal (top view) (Unit: mm)

4 Application Interface

4.1 Power Management

4.1.1 Power Input

The power supply range of SIM68V is from 2.8V to 4.3V. The power supply should be able to provide sufficient current up to 100mA.

4.1.2 Starting SIM68V

For initial power up, the RTC must start oscillating to sequence the Finite State Machine. RTC startup time may vary, when power is first applied, SIM68V goes into operation mode.

4.1.3 Verification of SIM68V Start

System activity indication depends upon the chosen serial interface:

When it is activated, SIM68V will output messages at the selected UART speed, and message types. The default baud rate is 115200bps.

Note: the baud rate information can be found on the label.

4.1.4 Power Saving Modes

SIM68V supports power saving modes for reducing average power consumption like sleep mode, backup mode, periodic mode, and AlwaysLocate™ mode.

- **Sleep mode:** In this mode the receiver stays at full on power state. This mode can be waken up by the host by sending the command through the communication interface or external interrupt.
- **Backup mode:** In this mode the SIM68V must be supplied by the backup battery and it can help to count down the time for backup mode. Software on host side to send the command through the communication interface to into the backup mode.
- **Periodic mode:** In this mode the SIM68V enters tracking and backup modes according to the interval configured by users in the commands.
- **AlwaysLocate™ mode:** AlwaysLocate™ is an intelligent controller of SIM68V periodic mode. Depending on the environment and motion conditions, SIM68V can adaptive adjust the on/off time to achieve balance of positioning accuracy and power consumption.

Note: The modes mentioned above are operated by PMTK commands, users can refer to “SIM28 / 68R / 68V NMEA Messages Specification” for more information.

SIM68V provides very low leakage battery back up memory, which contains all the necessary GNSS information for quick start up and a small amount of user configuration variables. It needs a 3V power supply for V_BACKUP pin, and the stable operation region ranges from very light load to about 3mA.

4.1.5 Operating Mode

Table 4: Power supply and clock state according to operation mode

Mode	VCC	V_BACKUP	Internal LDO	Main clock	RTC clock
Full on	on	on	on	on	on
Sleep	on	on	on	off	on
Backup	on	on	off	off	on

4.1.5.1 Full on Mode

The module will enter full on mode after first power up with factory configuration settings. Power consumption will vary depending on the amount of satellite acquisitions and number of satellites in track. This mode is also referenced as Full on, Full Power or Navigation mode.

Navigation is available and any configuration settings are valid as long as the VCC power supply is active. When the power supply is off, settings are reset to factory configuration and receiver performs a cold start on next power up.

4.1.5.2 Sleep Mode

Sleep mode means a low quiescent (340uA type.) power state, non-volatile RTC, and backup RAM block is powered on. Other internal blocks like digital baseband and RF are internally powered off. The power supply input VCC shall be kept active all the time, even during sleep mode.

Waking up from and entering into sleep mode is controlled by UART interface, any byte typing-in will drag SIM68V out of sleep mode.

4.1.6 Operating Mode

VCC_RF is a 2.8V output for external active antenna, if the external active antenna works at 2.8V voltage supply domain, the user can use the VCC_RF directly. If the antenna's power is not 2.8V, customer should connect the right voltage to the V_ANT as Figure 9 shows. For passive antennas, VCC_RF should be open.

4.2 UART Interface

SIM68V includes one configurable UART interface for serial communication. This UART support NEMA output and PMTK command input. The baud rate is selectable and ranging from 4.8 to 921.6kbps. UART can provide the developers signal or message outputs.

Table 5: Host port multiplexed function pins

Pin name	Pin number	UART function
----------	------------	---------------

TXD	20	data transmit
RXD	21	data receive

4.3 SPI Interface

The SPI interface is for connection of external serial flash to save configuration and A-GPS data. The SCS chip select signal is available to select external slaves. External SPI serial flash up to 128Mbits is supported.

Table 6 : SPI function pins

Pin name	Pin number	SPI function
MISO	15	Master input
MOSI	14	Master output
SCLK	16	Clock output
SCS	2	Chip select

4.4 I²C Interface

The SCL and SDA can be connected to an external I2C interface EEPROM up to 1 Mbits for reading and writing data into EEPROM. This can be used to store configurations permanently.

Note: The EEPROM and flash can't be supported synchronously.

4.5 Timemark Output

The Timemark pin outputs pulse-per-second (1PPS) pulse signal for precise timing purposes after the position has been fixed. The Timemark signal can be provided through designated output pin for many external applications. This pulse is not only limited to be active every second but also allowed to set the required duration, frequency, and active high/low by programming user-defined settings.

The following figure is the typical application of the TIMEMARK function.

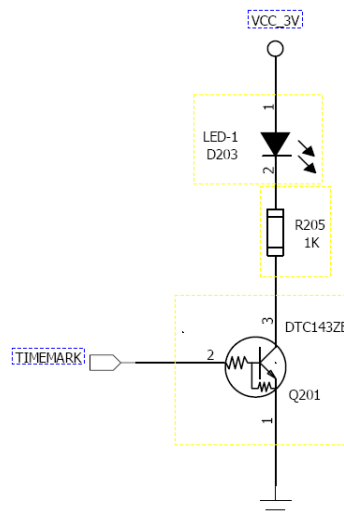

Figure 5: TIMEMARK application circuit

4.6 A-GPS

A-GPS is the meaning of Assisted GPS, which is a system that can under certain conditions improve the startup performance, or time-to-first-fix (TTFF) of a GPS satellite-based positioning system. SIM68V module supports EPO file, EASY mode and SBAS.

4.6.1 EPO

The SIM68V supports the EPO (Extended Prediction Orbit) data service. The EPO data service is supporting 7/14/30-day orbit predictions to customers. It needs occasional download from EPO server. Supply of aiding information like ephemeris, almanac, rough last position and time and satellite status and an optional time synchronization signal will reduce time to first fix significantly and improve the acquisition sensitivity.

The user should update the EPO files from the EPO server in the period of validity of EPO file through the internet. Then the EPO data should send to the SIM68V by the HOST side. SIM68V has the shorter cold TTFF and warm TTFF, when the A-GPS is used.

Note: For more information about EPO, please contact SIMCom sales.

4.6.2 EASY Mode

EASY is the abbreviation of Embedded Assist System, it works as embedded software which accelerates TTFF by predicting satellite navigation messages from received ephemeris.

No additional computing interval for EASY task. EASY is efficiently scheduled and computed in free time of every second after GPS navigation solution.

Easy function is conceptually designed to automatically engage for predicting after first receiving the broadcast ephemeris. After a while (generally tens of seconds), 3-day extensions will be completely generated then all EASY functions will be maintained at a standby condition. EASY assistance is going to be engaged when the GPS requests in new TTFF condition or re-generates again with another new received ephemeris. Meanwhile, TTFF will be benefited by EASY assistance.

Note: EASY function is default open and can be closed by PMTK command.

4.6.3 SBAS

SBAS is the abbreviation of Satellite Based Augmentation System. The SBAS concept is based on the transmission of differential corrections and integrity messages for navigation satellites that are within sight of a network of reference stations deployed across an entire continent. SBAS messages are broadcast via geostationary satellites able to cover vast areas.

Several countries have implemented their own satellite-based augmentation system. Europe has the European Geostationary Navigation Overlay Service (EGNOS) which covers Western Europe and beyond. The USA has its Wide Area Augmentation System (WAAS). Japan is covered by its Multi-functional Satellite Augmentation System (MSAS). India has launched its own SBAS program named GPS and GEO Augmented Navigation (GAGAN) to cover the Indian subcontinent.

4.7 Antenna

The antenna is the most critical item for successful GPS/GLONASS reception in a weak signal environment. Proper choice and placement of the antenna will ensure that satellites at all elevations can be seen, and therefore, accurate fix measurements are obtained.

It is recommended to use an active GPS/GLONASS antenna. In a typical application, SIM68V with an active antenna can get a tracking sensitivity about 3dB better than SIM68V with a passive antenna.

4.7.1 Antenna Interface

The SIM68V receives L1 band signals from GPS and GLONASS satellites at a nominal frequency of 1574~1606MHz . The RF signal is connected to the RF_IN pin. And the trace from RF_IN to antenna should be controlled to 50Ω impedance.

To suit the physical design of individual applications the RF interface pad can lead to two alternatives:

- Recommended approach: solderable RF coaxial cable assembly antenna connector, such as HRS' U.FL-R-SMT(10) connector or I-PEX's 20279-001E-01 RF connector.
- SMA connector.

4.7.2 Antenna Choice Consideration

To obtain excellent GNSS reception performance, a good antenna will always be required. Proper choice and placement of the antenna will ensure that satellites at all elevations can be seen, and therefore, accurate fix measurements are obtained.

It is suggested the active antenna should be chosen as following:

Table 7: Antenna Specifications

Parameter	Specification	Passive and active antenna
Active Antenna Recommendations	Frequency range	1574~1606MHz
	Polarization	RHCP
	Gain	>20dB (max 50 dB)
	Noise Figure	<1.5 dB

4.7.2.1 Passive Antenna

Passive antenna contains only the radiating element, e.g. the ceramic patch, the helix structure, and chip antennas. Sometimes it also contains a passive matching network to match the electrical connection to 50 Ohms impedance.

The most common antenna type for GPS/GLONASS application is the patch antenna. Patch antennas are flat, gen

erally have a ceramic and metal body and are mounted on a metal base plate.

Figure 6 shows a minimal setup for a GPS/GLONASS receiver with SIM68V module.

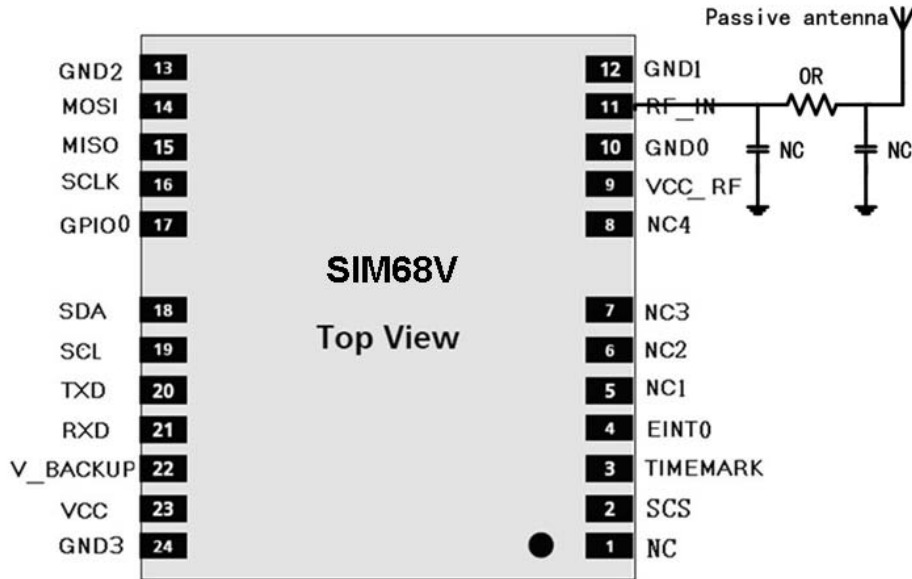

Figure 6: SIM68V passive antenna design

For best performance with passive antenna designs user can use an external LNA to increase the sensitivity up 3~4 dB. Please see Figure 7 and Figure 8.

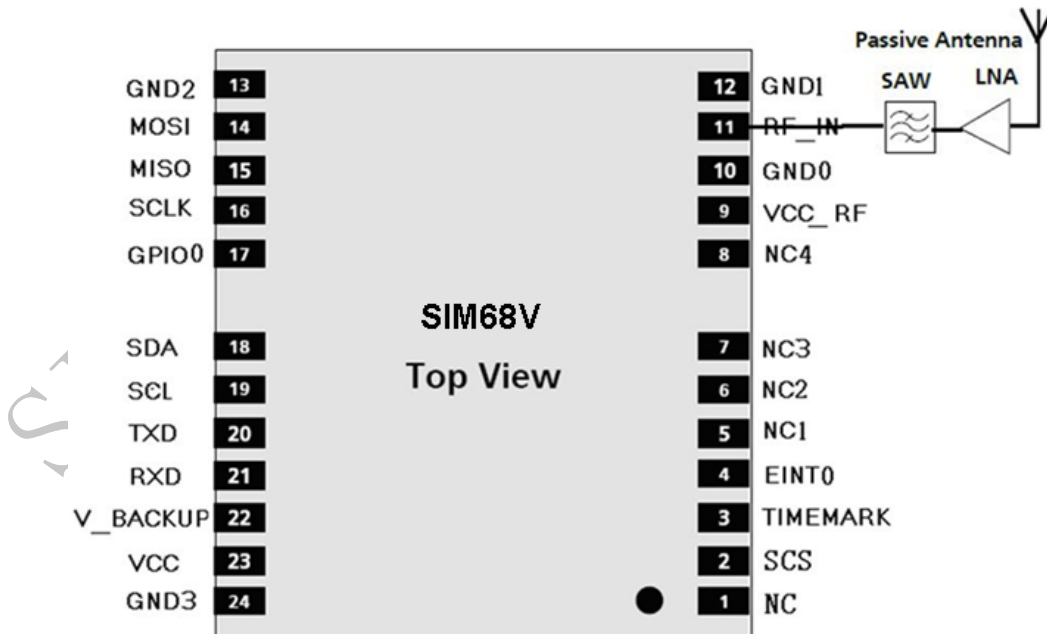

Figure 7: SIM68V passive antenna design (with external LNA and SAW)

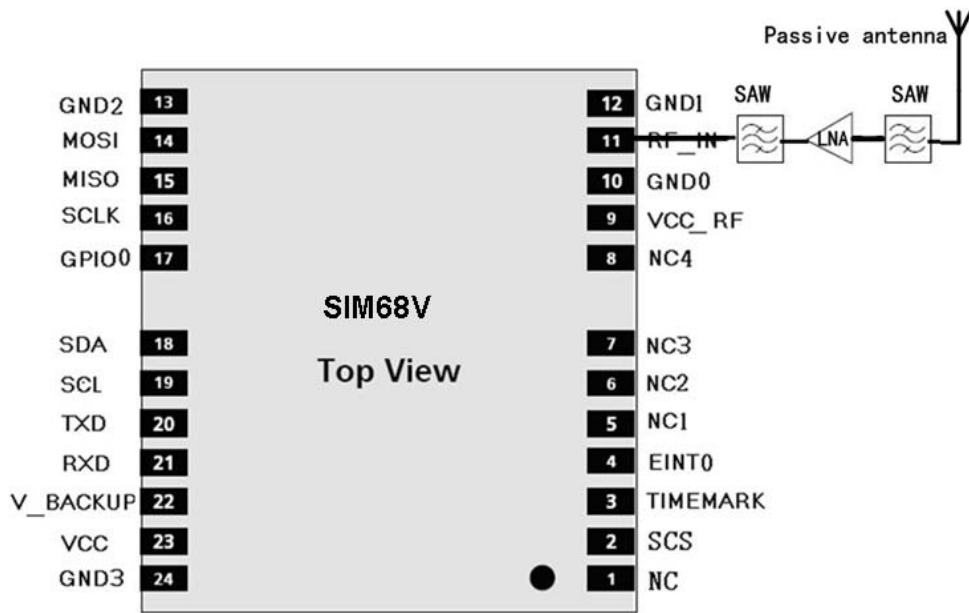

Figure 8: SIM68V passive antenna design for best performance and increased immunity

4.7.2.2 Active Antenna

Active antenna has an integrated Low-Noise Amplifier (LNA). Active antenna needs a power supply that will contribute to GNSS system power consumption.

Usually, the supply voltage is fed to the antenna through the coaxial RF cable shown as Figure 9. The output voltage of PIN 9 is 2.8V. If the supply voltage of active antenna is 2.8V, PIN 9 **VCC_RF** can be connected to **V_ANT** as figure 9 shows.

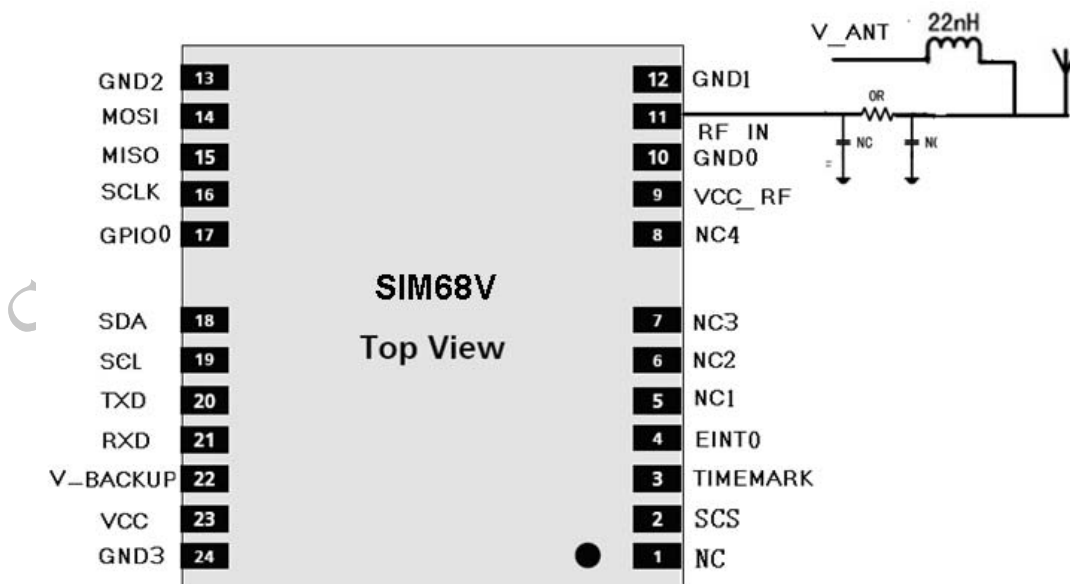

Figure 9: SIM68V active antenna design

If the customer’s design is for automotive applications, then an active antenna can be used and located on top of

the car in order to guarantee the best signal quality.

GNSS antenna choice should base on the designing product and other conditions. For detailed Antenna designing consideration, please refer to related antenna vendor's design recommendation. The antenna vendor will offer further technical support and tune their antenna characteristic to achieve successful GNSS reception performance depending on the customer's design.

SIMCOM CONFIDENTIAL FILE

5 Electrical, Reliability and Radio Characteristics

5.1 Absolute Maximum Ratings

The absolute maximum ratings stated in Table 8 are stress ratings under non-operating conditions. Stresses beyond any of these limits will cause permanent damage to SIM68V.

Table 8: Absolute maximum ratings

Parameter	Min	Max	Unit
VCC	-	4.3	V
RF_IN	-	TBD	V
V_BACKUP	2.3	4.6	V
I/O pin voltage	-	3.6	V
Storage temperature	-50	+125	°C
Operating Temperature	-40	+85	°C

Note: The absolute maximum rating of RF_IN please reference to the active antenna datasheet.

5.2 Recommended Operating Conditions

Table 9: SIM68V operating conditions

Parameter	Symbol	Min	Typ	Max	Unit
Operating temperature range		-40	+25	+85	°C
Main supply voltage	VCC	2.8	3	4.3	V
Active antenna supply voltage output	VCC_RF	2.7	2.8	2.9	V
	I _{max}			10	mA
Backup battery voltage	V_BACKUP	2.3		3.6	V

Table 10: SIM68V standard IO features

Parameter	Symbol	Min	Typ	Max	Unit
Low level output voltage Test conditions IOL = 2mA and 4.0mA	V _{ol}	-0.3		0.40	V
High level output voltage Test conditions IOL = 2mA and 4.0mA	V _{oh}	2.4		3.1	V
Low level input voltage	V _{il}	-0.3		0.8	V
High level input voltage	V _{ih}	2.0		3.6	V
Input Pull-up resistance	RPU	40		190	K Ω
Input Pull-down resistance	RPD	40		190	K Ω
Input capacitance	C _{in}		5		pF
Load capacitance	C _{load}			8	pF

Tri-state leakage current	IOZ	-10		10	uA
---------------------------	-----	-----	--	----	----

5.3 Electro-Static Discharge

The GPS engine is not protected against Electrostatic Discharge (ESD) in general. Therefore, it is subject to ESD handling precautions that typically apply to ESD sensitive components. Proper ESD handling and packaging procedures must be applied throughout the processing, handling and operation of any application using a SIM68V module.

Table 11: The ESD characteristics (Temperature: 25°C, Humidity: 45 %)

Pin	Contact discharge (KV)	Air discharge (KV)
VCC	±5	±10
GND	±4	±9
VCC_RF	±4	±10
RF_IN	±4	±10

SIMCOM CONFIDENTIAL

6 Manufacturing

6.1 Top and bottom View of SIM68V



Figure 10: Top and bottom view of SIM68V

6.2 Label information



Figure 11: Label of SIM68V

Table 12: illustration of module information

Item	Description
A	Logo of SIMCom
B	Module name
C	Module part number Hardware number and software number included; ex.S2-105A5 is hardware number Z0Z02 is software number
D	Module serial number The first number stands for factory code; The second number stands for year code; The third to eighth numbers is the SN number in hexadecimal numeric; The last two numbers stands for MNEA sentence baud rate, “11” stands for 115200, “96” stands for 9600;
E	Module bar code Stands for the first 6 numbers of SN number
F	PIN 1 Mark

6.3 Assembly and Soldering

The SIM68V module is intended for SMT assembly and soldering in a Pb-free reflow process on the top side of the PCB. Suggested solder paste stencil height is 150um minimum to ensure sufficient solder volume. If required paste mask pad openings can be increased to ensure proper soldering and solder wetting over pads.

The following figure is the Ramp-Soak-Spike Reflow Profile of SIM68V:

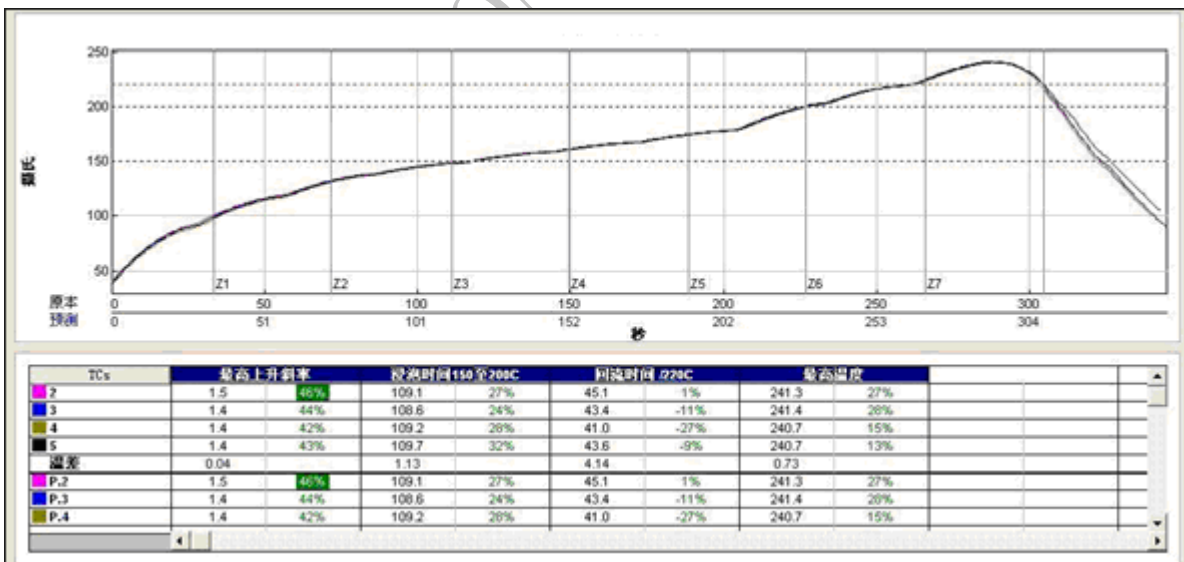

Figure 12: The Ramp-Soak-Spike reflow profile of SIM68V

SIM68V is Moisture Sensitive Devices (MSD), appropriate MSD handling instruction and precautions are summarized in Chapter 6.3.

SIM68V modules are also Electrostatic Sensitive Devices (ESD), handling SIM68V modules without proper ESD

protection may destroy or damage them permanently.

Avoid ultrasonic exposure due to internal crystal and SAW components.

6.4 Moisture sensitivity

SIM68V module is moisture sensitive at MSL level 3, dry packed according to IPC/JEDEC specification J-STD-020C. The calculated shelf life for dry packed SMD packages is a minimum of 12 months from the bag seal date, when stored in a non condensing atmospheric environment of <40°C/90% RH.

Table 12 lists floor life for different MSL levels in the IPC/JDEC specification:

Table 13: Moisture Classification Level and Floor Life

Level	Floor Life(out of bag)at factory ambient $\cong +30^{\circ}\text{C}/60\%\text{RH}$ or as stated
1	Unlimited at $\cong +30^{\circ}\text{C}/85\% \text{RH}$
2	1 year
2a	4 weeks
3	168 hours
4	72 hours
5	48 hours
5a	24 hours
6	Mandatory bake before use. After bake, module must be reflowed within the time limit specified on the label.

Factory floor life is 1 week for MSL 3, SIM68V must be processed and soldered within the time. If this time is exceeded, or the humidity indicator card in the sealed package indicates that they have been exposed to moisture, the devices need to be pre-baked before the reflow solder process.

Both encapsulate and substrate materials absorb moisture. IPC/JEDEC specification J-STD-020 must be observed to prevent cracking and delamination associated with the "popcorn" effect during reflow soldering. The popcorn effect can be described as miniature explosions of evaporating moisture. Baking before processing is required in the following cases:

- Humidity indicator card: At least one circular indicator is no longer blue
- Floor life or environmental requirements after opening the seal have been exceeded, e.g. exposure to excessive seasonal humidity.

Refer to Section 4 of IPC/JEDEC J-STD-033 for recommended baking procedures.

Note: Oxidation Risk: Baking SMD packages may cause oxidation and/or inter metallic growth of the terminations, which if excessive can result in solder ability problems during board assembly. The temperature and time for baking SMD packages are therefore limited by solder ability considerations. The cumulative bake time at a temperature greater than 90°C and up to 125°C shall not exceed 96 hours.

6.5 ESD handling precautions

SIM68V modules are Electrostatic Sensitive Devices (ESD). Observe precautions for handling! Failure to observe these precautions can result in severe damage to the GPS receiver!



GPS receivers are Electrostatic Sensitive Devices (ESD) and require special precautions when handling. Particular care must be exercised when handling patch antennas, due to the risk of electrostatic charges. In addition to standard ESD safety practices, the following measures should be taken into account whenever handling the receiver:

Unless there is a galvanic coupling between the local GND (i.e. the work Table) and the PCB GND, then the first point of contact when handling the PCB shall always be between the local GND and PCB GND.
Before mounting an antenna patch, connect ground of the device

When handling the RF pin, do not come into contact with any charged capacitors and be careful when contacting materials that can develop charges (e.g. patch antenna ~10pF, coax cable ~50-80pF/m, soldering iron, ...)
To prevent electrostatic discharge through the RF input, do not touch the mounted patch antenna.

When soldering RF connectors and patch antennas to the receiver's RF pin, the user must make sure to use an ESD safe soldering iron (tip).

6.6 Shipment

SIM68V is designed and packaged to be processed in an automatic assembly line, and it is now packaged in SIM68V tray.

7 Reference Design

Following figure is the typical application of SIM68V with active antenna which supplied by VCC_RF. If customer applies other kind of active antenna, keep PIN 9 floating and connect other voltage to the L101.

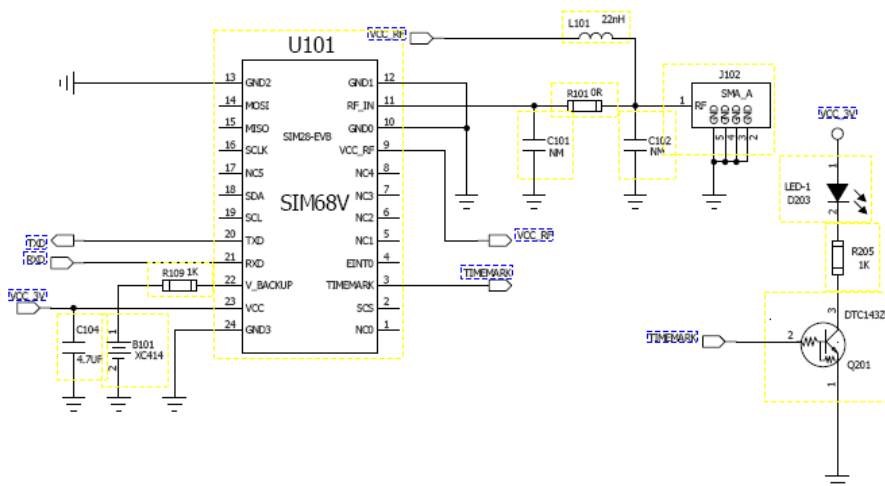

Figure 13: Example application schematic with UART

Note: The I/Os of SIM68V are 2.8V CMOS voltage level, attentions should be paid if the voltage level of the host controller not compatible.

Appendix

A. Related Documents

Table 14: Related documents

SN	Document name	Remark
[1]	SIM68V_EVB-UG	
[2]	SIM28 / 68R / 68V NMEA Messages SpecificationV1.01	

B. Terms and Abbreviations

Table 15: Terms and abbreviations

Abbreviation	Description
A-GPS	Assisted- Global Positioning System
CMOS	Complementary Metal Oxide Semiconductor
DGPS	Difference Global Positioning System
EASY	Embedded Assist System
EEPROM	Electrically Erasable Programmable Read Only Memory
EGNOS	Euro Geostationary Navigation Overlay Service
EPO	Extended Prediction Orbit
ESD	Electrostatic Sensitive Devices
FSM	Finite State Machine
GAGAN	The GPS Aided Geo Augmented Navigation
GPS	Global Positioning System
GNSS	Global Navigation Satellite System
I/O	Input/Output
IC	Integrated Circuit
Inorm	Normal Current
Imax	Maximum Load Current
kbps	Kilo bits per second
KA	Keep alive
LNA	Low Noise Amplifier
MSAS	Multi-Functional Satellite Augmentation
MSL	moisture sensitive level
NEMA	National Marine Electronics Association

QZSS	Quasi-Zenith Satellites System
SBAS	Satellite Based Augmentation Systems
WAAS	Wide Area Augmentation System

SIMCOM CONFIDENTIAL FILE

Contact us:**Shanghai SIMCom Wireless Solutions Ltd.**

Add: SIM Technology Building, No.633, Jinzhong Road, Changning District, Shanghai P.R. China
200335

Tel: +86 21 3235 3300

Fax: +86 21 3235 3301

URL: www.sim.com/wm

SIMCOM CONFIDENTIAL FILE