

TPS54531 5-A, 28-V Input, Step-Down SWIFT™ DC-DC Converter With Eco-mode™

1 Features

- 3.5 to 28-V Input Voltage Range
- Adjustable Output Voltage Down to 0.8 V
- Integrated 80-mΩ High-Side MOSFET Supports up to 5-A Continuous Output Current
- High Efficiency at Light Loads with a Pulse Skipping Eco-mode™
- Fixed 570kHz Switching Frequency
- Typical 1µA Shutdown Quiescent Current
- Adjustable Slow Start Limits Inrush Currents
- Programmable UVLO Threshold
- Overvoltage Transient Protection
- Cycle-by-Cycle Current-Limit, Frequency Fold Back, and Thermal Shutdown Protection
- Available in Easy-to-Use Thermally Enhanced 8-Pin SO PowerPAD™ Package

2 Applications

- Consumer Applications such as Set-Top Boxes, CPE Equipment, LCD Displays, Peripherals, and Battery Chargers
- Industrial and Car Audio Power Supplies
- 5-V, 12-V and 24-V Distributed Power Systems

4 Simplified Schematic

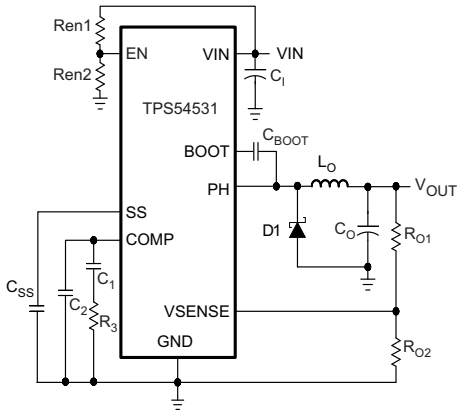

3 Description

The TPS54531 device is a 28-V, 5-A non-synchronous buck converter that integrates a low $R_{DS(on)}$ high-side MOSFET. To increase efficiency at light loads, a pulse skipping Eco-mode feature is automatically activated. Furthermore, the 1-µA shutdown supply current allows the device to be used in battery powered applications. Current mode control with internal slope compensation simplifies the external compensation calculations and reduces component count while allowing the use of ceramic output capacitors. A resistor divider programs the hysteresis of the input under-voltage lockout. An overvoltage transient protection circuit limits voltage overshoots during startup and transient conditions. A cycle-by-cycle current-limit scheme, frequency fold back, and thermal shutdown protect the device and the load in the event of an overload condition. The TPS54531 device is available in 8-pin SO PowerPAD™ package that has been internally optimized to improve thermal performance.

Device Information⁽¹⁾

PART NUMBER	PACKAGE	BODY SIZE (NOM)
TPS54531	SO PowerPAD (8)	4.90 mm x 3.90 mm

(1) For all available packages, see the orderable addendum at the end of the datasheet.

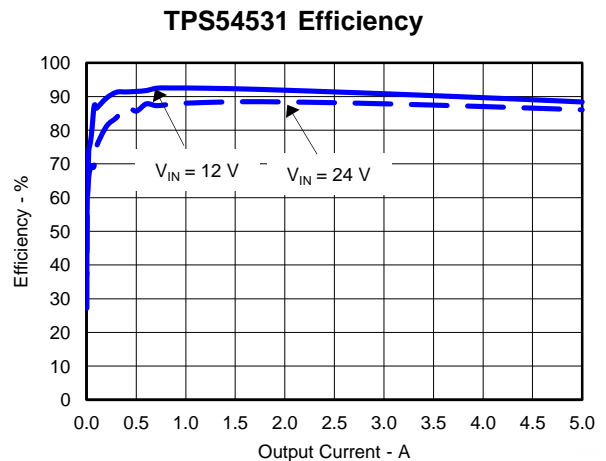

Table of Contents

1 Features	1	8.4 Device Functional Modes.....	12
2 Applications	1	9 Application and Implementation	13
3 Description	1	9.1 Application Information.....	13
4 Simplified Schematic	1	9.2 Typical Application	13
5 Revision History	2	10 Power Supply Recommendations	22
6 Pin Configuration and Functions	3	11 Layout	22
7 Specifications	4	11.1 Layout Guidelines	22
7.1 Absolute Maximum Ratings	4	11.2 Layout Example	23
7.2 Handling Ratings.....	4	11.3 Electromagnetic Interference (EMI) Considerations	23
7.3 Recommended Operating Conditions.....	4	12 Device and Documentation Support	24
7.4 Thermal Information	5	12.1 Device Support.....	24
7.5 Electrical Characteristics.....	5	12.2 Trademarks	24
7.6 Typical Characteristics.....	6	12.3 Electrostatic Discharge Caution.....	24
8 Detailed Description	8	12.4 Glossary	24
8.1 Overview	8	13 Mechanical, Packaging, and Orderable Information	24
8.2 Functional Block Diagram	9		
8.3 Feature Description.....	9		

5 Revision History

Changes from Original (May 2013) to Revision A

Page

- Added the *Handling Ratings* table, *Feature Description* section, *Device Functional Modes* section, *Application and Implementation* section, *Power Supply Recommendations* section, *Layout* section, *Device and Documentation Support* section, and *Mechanical, Packaging, and Orderable Information* section **1**
- Added equation for I_{ripple} in the *Inductor Selection* section **15**

6 Pin Configuration and Functions

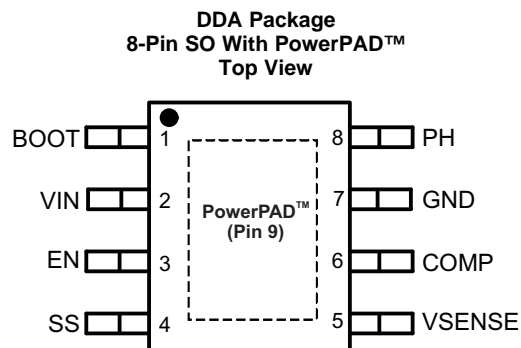

Pin Functions

PIN		I/O	DESCRIPTION
NO.	NAME		
1	BOOT	O	A 0.1- μ F bootstrap capacitor is required between the BOOT and PH pins. If the voltage on this capacitor falls below the minimum requirement, the high-side MOSFET is forced to switch off until the capacitor is refreshed.
2	VIN	I	This pin is the 3.5- to 28-V input supply voltage.
3	EN	I	This pin is the enable pin. To disable, pull below 1.25 V. Float this pin to enable. Programming the input undervoltage lockout with two resistors is recommended.
4	SS	I	This pin is slow-start pin. An external capacitor connected to this pin sets the output rise time.
5	VSENSE	I	This pin is the inverting node of the transconductance (gm) error amplifier.
6	COMP	O	This pin is the error-amplifier output and the input to the PWM comparator. Connect frequency compensation components to this pin.
7	GND	—	Ground pin
8	PH	O	The PH pin is the source of the internal high-side power MOSFET.
9	PowerPAD™	—	For proper operation, the GND pin must be connected to the exposed pad.

7 Specifications

7.1 Absolute Maximum Ratings⁽¹⁾

over operating free-air temperature range (unless otherwise noted)

		MIN	MAX	UNIT
Input Voltage	VIN	-0.3	30	V
	EN	-0.3	6	
	BOOT		38	
	VSENSE	-0.3	3	
	COMP	-0.3	3	
	SS	-0.3	3	
Output Voltage	BOOT-PH		8	V
	PH	-0.6	30	
	PH (10 ns transient from ground to negative peak)		-5	
Source Current	EN		100	μA
	BOOT		100	mA
	VSENSE		10	μA
	PH	Current Limit		A
Sink Current	VIN	Current Limit		A
	COMP		100	μA
	SS		200	
Operating Junction Temperature		-40	150	°C

- (1) Stresses beyond those listed under absolute maximum ratings may cause permanent damage to the device. These are stress ratings only, and functional operation of the device at these or any other conditions beyond those indicated under recommended operating conditions is not implied. Exposure to absolute-maximum-rated conditions for extended periods may affect device reliability.

7.2 Handling Ratings

		MIN	MAX	UNIT	
T _{stg}	Storage temperature range	-65	150	°C	
V _(ESD)	Electrostatic discharge	Human body model (HBM), per ANSI/ESDA/JEDEC JS-001, all pins ⁽¹⁾	-2	2	kV
		Charged device model (CDM), per JEDEC specification JESD22-C101, all pins ⁽²⁾	-1	1	

- (1) JEDEC document JEP155 states that 500-V HBM allows safe manufacturing with a standard ESD control process.
 (2) JEDEC document JEP157 states that 250-V CDM allows safe manufacturing with a standard ESD control process.

7.3 Recommended Operating Conditions

over operating free-air temperature range (unless otherwise noted)

		MIN	MAX	UNIT
	Operating Input Voltage on the VIN pin	3.5	28	V
T _J	Operating junction temperature	-40	150	°C

7.4 Thermal Information

THERMAL METRIC ⁽¹⁾		DDA 8 PINS	UNIT
R _{θJA}	Junction-to-ambient thermal resistance	55	°C/W
R _{θJC(top)}	Junction-to-case (top) thermal resistance	63.2	
R _{θJB}	Junction-to-board thermal resistance	31.5	
Ψ _{JT}	Junction-to-top characterization parameter	14.9	
Ψ _{JB}	Junction-to-board characterization parameter	31.4	
R _{θJC(bot)}	Junction-to-case (bottom) thermal resistance	8.3	

(1) For more information about traditional and new thermal metrics, see the *IC Package Thermal Metrics* application report, [SPRA953](#).

7.5 Electrical Characteristics

T_J = –40°C to 150°C, V_{IN} = 3.5V to 28V (unless otherwise noted)

PARAMETER	TEST CONDITIONS	MIN	TYP	MAX	UNIT
SUPPLY VOLTAGE (VIN PIN)					
Internal undervoltage lockout threshold	Rising and falling			3.5	V
Shutdown supply current	EN = 0V, V _{IN} = 12V, –40°C to 85°C		1	4	μA
Operating – non-switching supply current	V _{SENSE} = 0.85 V		110	190	μA
ENABLE AND UVLO (EN PIN)					
Enable threshold	Rising and falling		1.25	1.35	V
Input current	Enable threshold – 50 mV		–1		μA
Input current	Enable threshold + 50 mV		–4		μA
VOLTAGE REFERENCE					
Voltage reference		0.772	0.8	0.828	V
HIGH-SIDE MOSFET					
On resistance	BOOT-PH = 3 V, V _{IN} = 3.5 V		115	200	mΩ
	BOOT-PH = 6 V, V _{IN} = 12 V		80	150	
ERROR AMPLIFIER					
Error amplifier transconductance (gm)	–2 μA < I _(COMP) < 2 μA, V _(COMP) = 1 V		92		μmos
Error amplifier DC gain ⁽¹⁾	V _{SENSE} = 0.8 V		800		V/V
Error amplifier unity gain bandwidth ⁽¹⁾	5 pF capacitance from COMP to GND pins		2.7		MHz
Error amplifier source/sink current	V _(COMP) = 1 V, 100-mV overdrive		±7		μA
Switch current to COMP transconductance ⁽¹⁾	V _{IN} = 12 V		20		A/V
SWITCHING FREQUENCY					
Switching Frequency	V _{IN} = 12V, 25°C	456	570	684	kHz
Minimum controllable on time	V _{IN} = 12V, 25°C		105	130	ns
Maximum controllable duty ratio ⁽¹⁾	BOOT-PH = 6 V	90%	93%		
PULSE SKIPPING Eco-mode™					
Pulse skipping Eco-mode switch current threshold			160		mA
CURRENT LIMIT					
Current-limit threshold	V _{IN} = 12 V	6.3	10.5		A
THERMAL SHUTDOWN					
Thermal Shutdown			165		°C
SLOW START (SS PIN)					
Charge current	V _(SS) = 0.4 V		2		μA

(1) Specified by design

7.6 Typical Characteristics

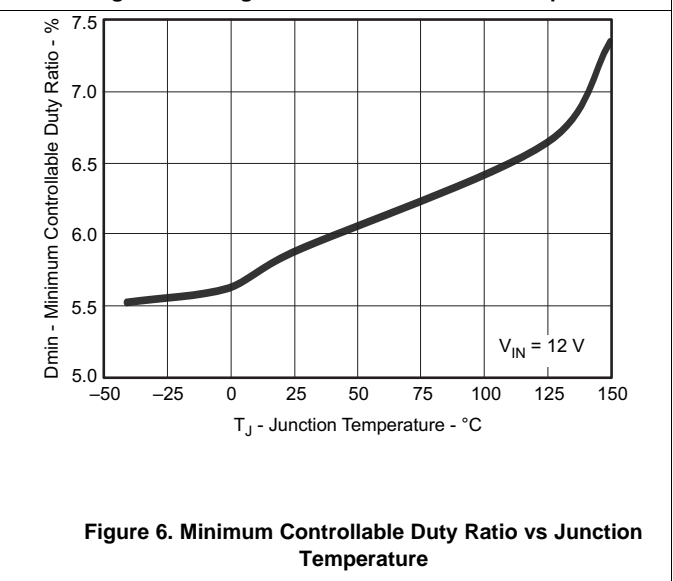
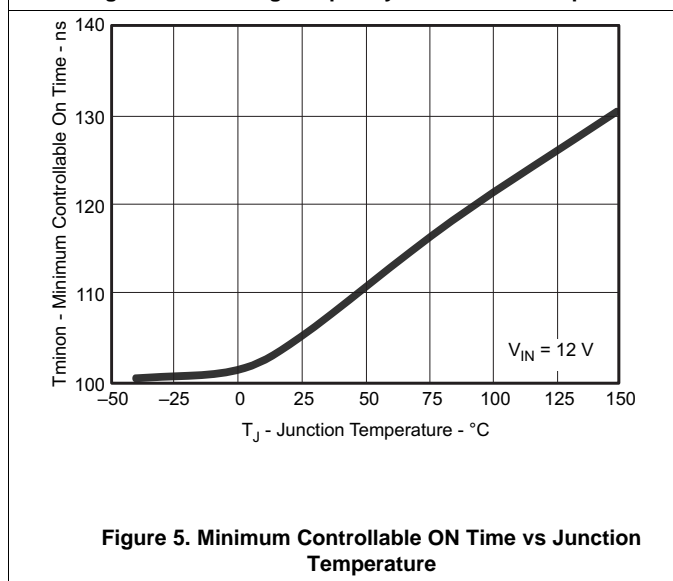
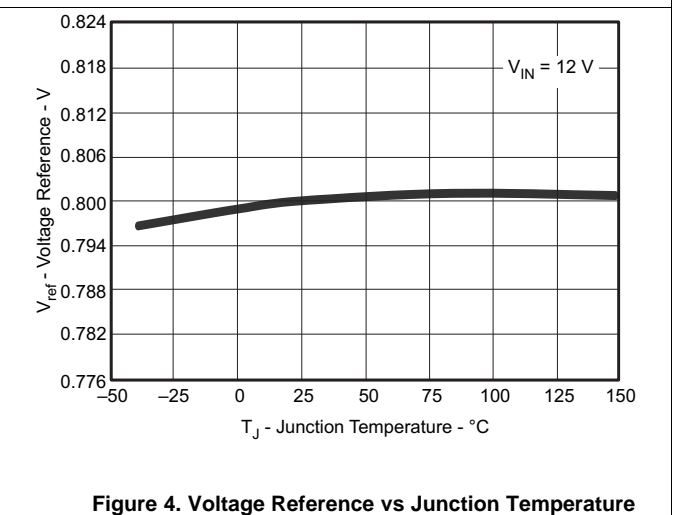
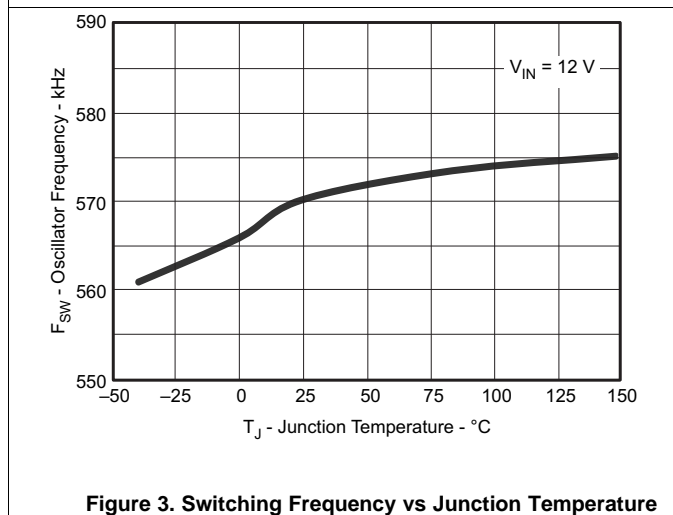
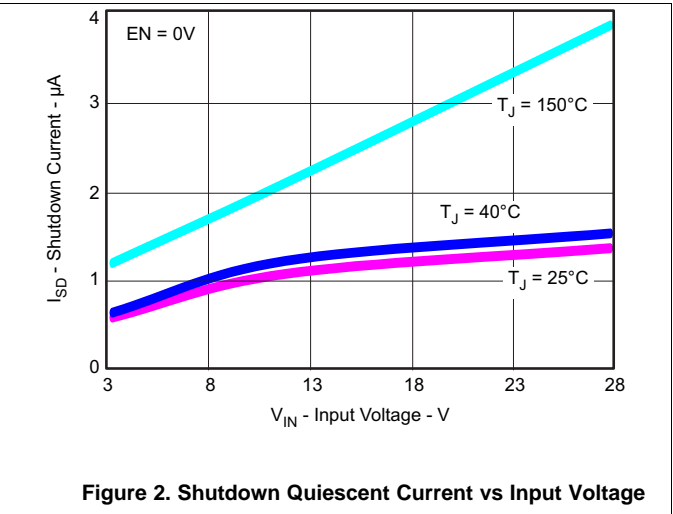
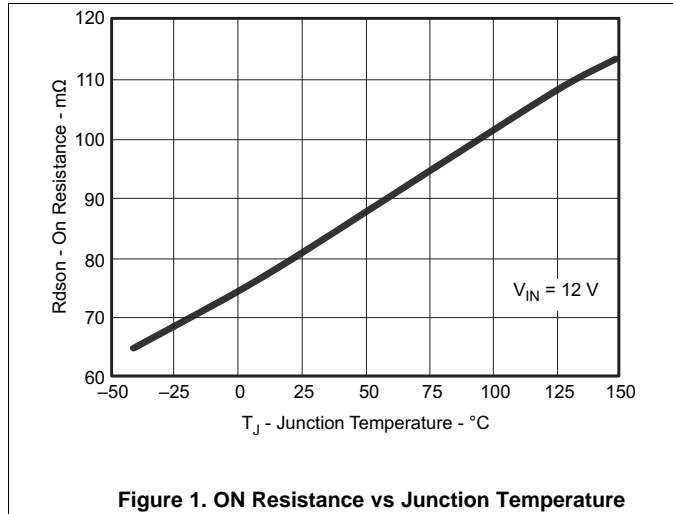

Typical Characteristics (continued)

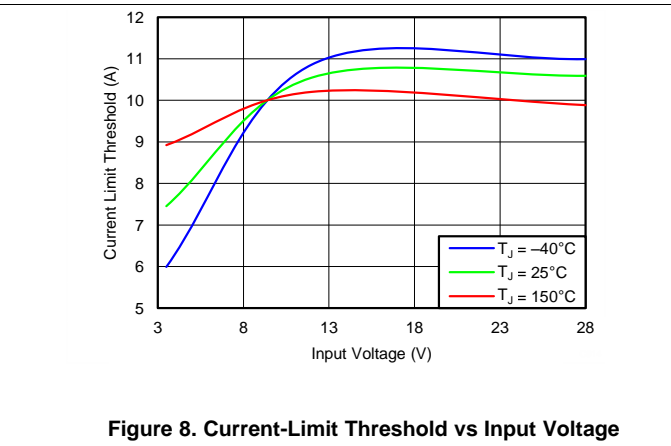
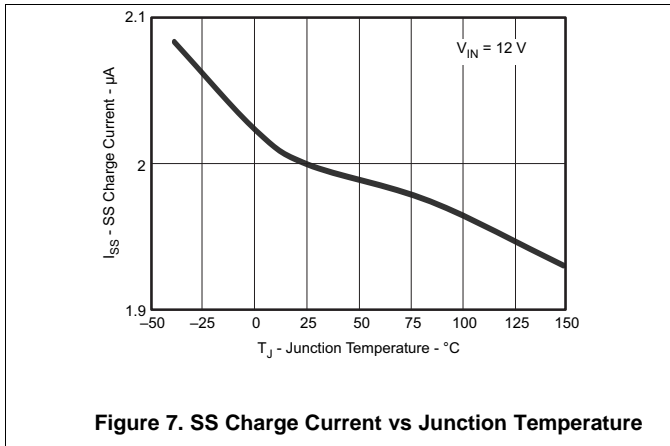

8 Detailed Description

8.1 Overview

The TPS54531 device is a 28-V, 5-A, step-down (buck) converter with an integrated high-side n-channel MOSFET. To improve performance during line and load transients, the device implements a constant-frequency, current mode control which reduces output capacitance and simplifies external frequency compensation design. The TPS54531 device has a preset switching frequency of 570 kHz.

The TPS54531 device requires a minimum input voltage of 3.5 V for normal operation. The EN pin has an internal pullup current source that can be used to adjust the input-voltage undervoltage lockout (UVLO) with two external resistors. In addition, the pullup current provides a default condition when the EN pin is floating for the device to operate. The operating current is 110 μ A (typical) when not switching and under no load. When the device is disabled, the supply current is 1 μ A (typical).

The integrated 80-m Ω high-side MOSFET allows for high-efficiency power-supply designs with continuous output currents up to 5 A.

The TPS54531 device reduces the external component count by integrating the boot recharge diode. The bias voltage for the integrated high-side MOSFET is supplied by an external capacitor on the BOOT to PH pin. The boot capacitor voltage is monitored by an UVLO circuit and turns the high-side MOSFET off when the voltage falls below a preset threshold of 2.1 V (typical). The output voltage can be stepped down to as low as the reference voltage.

By adding an external capacitor, the slow-start time of the TPS54531 device can be adjustable which enables flexible output filter selection.

To improve the efficiency at light load conditions, the TPS54531 device enters a special pulse skipping Eco-mode when the peak inductor current drops below 160 mA (typical).

The frequency foldback reduces the switching frequency during startup and overcurrent conditions to help control the inductor current. The thermal shut down provides the additional protection under fault conditions.

8.2 Functional Block Diagram

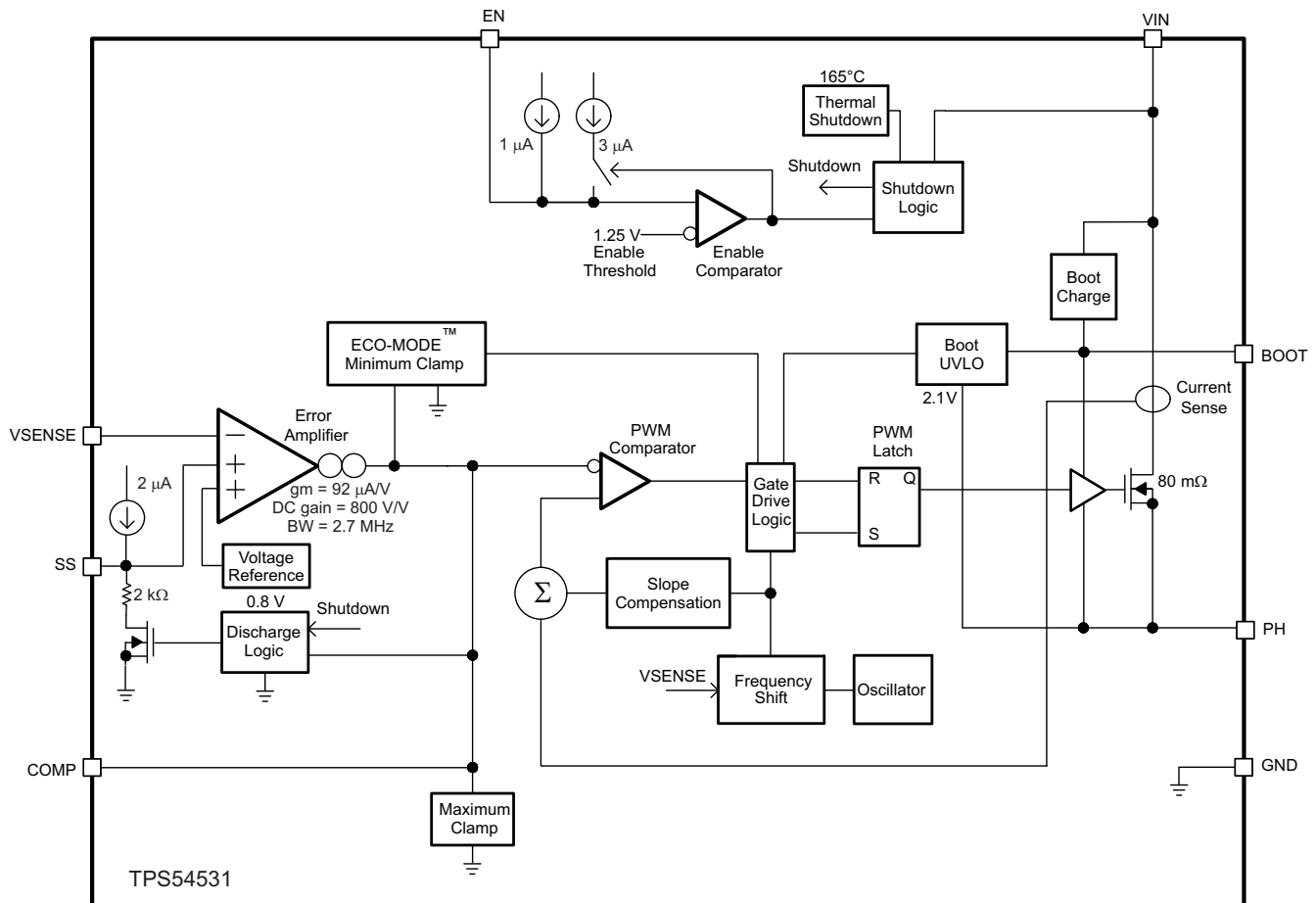

8.3 Feature Description

8.3.1 Fixed-Frequency PWM Control

The TPS54531 device uses a fixed-frequency, peak-current mode control. The internal switching frequency of the TPS54531 device is fixed at 570 kHz.

8.3.2 Voltage Reference (V_{ref})

The voltage reference system produces a $\pm 2\%$ initial accuracy voltage reference ($\pm 3.5\%$ over temperature) by scaling the output of a temperature stable bandgap circuit. The typical voltage reference is designed at 0.8 V.

8.3.3 Bootstrap Voltage (BOOT)

The TPS54531 device has an integrated boot regulator and requires a 0.1- μF ceramic capacitor between the BOOT and PH pins to provide the gate-drive voltage for the high-side MOSFET. A ceramic capacitor with an X7R- or X5R-grade dielectric is recommended because of the stable characteristics over temperature and voltage. To improve drop out, the TPS54531 device is designed to operate at 100% duty cycle as long as the BOOT-to-PH pin voltage is greater than 2.1 V (typical).

8.3.4 Enable and Adjustable Input Undervoltage Lockout (VIN UVLO)

The EN pin has an internal pullup current-source that provides the default condition of the TPS54531 device while operating when the EN pin floats.

Feature Description (continued)

8.3.6 Error Amplifier

The TPS54531 device has a transconductance amplifier for the error amplifier. The error amplifier compares the VSENSE voltage to the internal effective voltage reference presented at the input of the error amplifier. The transconductance of the error amplifier is 92 $\mu\text{A/V}$ during normal operation. Frequency compensation components are connected between the COMP pin and ground.

8.3.7 Slope Compensation

In order to prevent the sub-harmonic oscillations when operating the device at duty cycles greater than 50%, the TPS54531 device adds a built-in slope compensation which is a compensating ramp to the switch-current signal.

8.3.8 Current-Mode Compensation Design

The device is able to work with various types of output capacitors with appropriate compensation designs. For designs using ceramic output capacitors, proper derating of ceramic output capacitance is recommended when performing the stability analysis because the actual ceramic capacitance drops considerably from the nominal value when the applied voltage increases. For the detailed guidelines, see the [Detailed Design Procedure](#) section.

8.3.9 Overcurrent Protection and Frequency Shift

The TPS54531 device implements current mode control that uses the COMP pin voltage to turn off the high-side MOSFET on a cycle-by-cycle basis. During each cycle the switch current and the COMP pin voltage are compared. When the peak inductor current intersects the COMP pin voltage, the high-side switch is turned off. During overcurrent conditions that pull the output voltage low, the error amplifier responds by driving the COMP pin high, causing the switch current to increase. The COMP pin has a maximum clamp internally, which limits the output current.

The TPS54531 device provides robust protection during short circuits. Overcurrent runaway is possible in the output inductor during a short circuit at the output. The TPS54531 device solves this issue by increasing the off time during short-circuit conditions by lowering the switching frequency. The switching frequency is divided by 1, 2, 4, and 8 as the voltage ramps from 0 V to 0.8 V on VSENSE pin. The relationship between the switching frequency and the VSENSE pin voltage is listed in [Table 1](#).

Table 1. Switching Frequency Conditions

SWITCHING FREQUENCY	VSENSE PIN VOLTAGE
570 kHz	$V_{\text{SENSE}} \geq 0.6 \text{ V}$
570 kHz / 2	$0.6 \text{ V} > V_{\text{SENSE}} \geq 0.4 \text{ V}$
570 kHz / 4	$0.4 \text{ V} > V_{\text{SENSE}} \geq 0.2 \text{ V}$
570 kHz / 8	$0.2 \text{ V} > V_{\text{SENSE}}$

8.3.10 Overvoltage Transient Protection

The TPS54531 device incorporates an overvoltage transient-protection (OVTP) circuit to minimize output voltage overshoot when recovering from output fault conditions or strong unload transients. The OVTP circuit includes an overvoltage comparator to compare the VSENSE pin voltage and internal thresholds. When the VSENSE pin voltage goes above $109\% \times V_{\text{ref}}$, the high-side MOSFET is forced off. When the VSENSE pin voltage falls below $107\% \times V_{\text{ref}}$, the high-side MOSFET is enabled again.

8.3.11 Thermal Shutdown

The device implements an internal thermal shutdown to protect the device if the junction temperature exceeds 165°C. The thermal shutdown forces the device to stop switching when the junction temperature exceeds the thermal trip threshold. When the die temperature decreases below 165°C, the device reinitiates the power-up sequence.

8.4 Device Functional Modes

8.4.1 Eco-mode™

The TPS54531 is designed to operate in pulse skipping Eco-mode at light load currents to boost light load efficiency. When the peak inductor current is lower than 160 mA (typical), the COMP pin voltage falls to 0.5 V (typical) and the device enters Eco-mode. When the device is in Eco-mode, the COMP pin voltage is clamped at 0.5-V internally which prevents the high-side integrated MOSFET from switching. The peak inductor current must rise above 160 mA for the COMP pin voltage to rise above 0.5 V and exit Eco-mode. Because the integrated current comparator catches the peak inductor current only, the average load current entering Eco-mode varies with the applications and external output filters.

8.4.2 Operation With $V_{IN} < 3.5$ V

The device is recommended to operate with input voltages above 3.5 V. The typical VIN UVLO threshold is not specified and the device can operate at input voltages down to the UVLO voltage. At input voltages below the actual UVLO voltage, the device does not switch. If the EN pin is externally pulled up or left floating, the device becomes active when the VIN pin passes the UVLO threshold. Switching begins when the slow-start sequence is initiated.

8.4.3 Operation With EN Control

The enable threshold voltage is 1.25 V (typical). With the EN pin is held below that voltage the device is disabled and switching is inhibited even if the VIN pin is above the UVLO threshold. The IC quiescent current is reduced in this state. If the EN voltage increases above the threshold while the VIN pin is above the UVLO threshold, the device becomes active. Switching is enabled, and the slow-start sequence is initiated.

9 Application and Implementation

NOTE

Information in the following applications sections is not part of the TI component specification, and TI does not warrant its accuracy or completeness. TI's customers are responsible for determining suitability of components for their purposes. Customers should validate and test their design implementation to confirm system functionality.

9.1 Application Information

The TPS54531 device is typically used as a step-down converter, which converts a voltage from 3.5 V to 28 V to a lower voltage. WEBENCH® software is available to aid in the design and analysis of circuits.

For additional design needs, see the following devices:

	TPS54231	TPS54232	TPS54233	TPS54531	TPS54332
I(max)	2 A	2 A	2 A	5 A	3.5 A
Input voltage range	3.5 to 28 V	3.5 to 28 V	3.5 to 28 V	3.5 to 28 V	3.5 to 28 V
Switching frequency (typ)	570 kHz	1000 kHz	285 kHz	570 kHz	1000 kHz
Switch current limit (min)	2.3 A	2.3 A	2.3 A	5.5 A	4.2 A
Pin and package	8SOIC	8SOIC	8SOIC	8SO PowerPAD™	8SO PowerPAD™

9.2 Typical Application

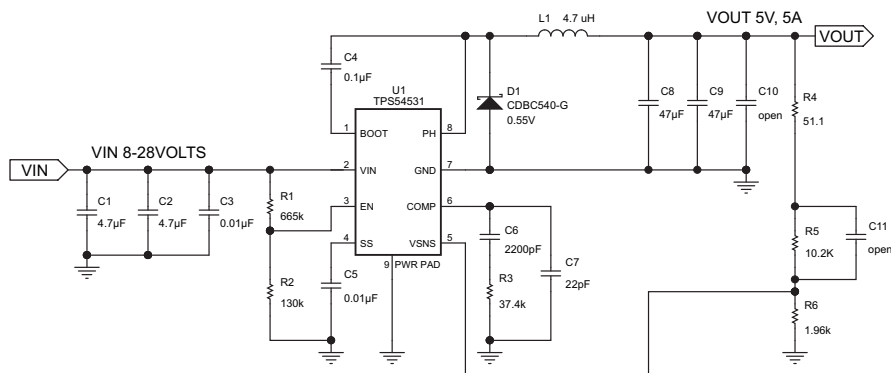

Figure 10. Typical Application Schematic

9.2.1 Design Requirements

For this design example, use the values listed in Table 2 as the input parameters

Table 2. Design Parameters

DESIGN PARAMETER	EXAMPLE VALUE
Input voltage range	8 to 28 V
Output voltage	5 V
Transient response, 2.5-A load step	$\Delta V_{OUT} = \pm 5\%$
Input ripple voltage	400 mV
Output ripple voltage	30 mV
Output current rating	5 A
Operating Frequency	570 kHz

9.2.2 Detailed Design Procedure

The following design procedure can be used to select component values for the TPS54531 device. Alternately, the WEBENCH software can be used to generate a complete design. The WEBENCH software uses an iterative design procedure and accesses a comprehensive database of components when generating a design. This section presents a simplified discussion of the design process.

9.2.2.1 Switching Frequency

The switching frequency for the TPS54531 is fixed at 570 kHz.

9.2.2.2 Output Voltage Set Point

The output voltage of the TPS54531 device is externally adjustable using a resistor divider network. As shown in [Figure 10](#), this divider network is comprised of R5 and R6. The relationship of the output voltage to the resistor divider is given by [Equation 4](#) and [Equation 5](#):

$$R6 = \frac{R5 \times V_{\text{ref}}}{V_{\text{OUT}} - V_{\text{ref}}} \quad (4)$$

$$V_{\text{OUT}} = V_{\text{ref}} \times \left[\frac{R5}{R6} + 1 \right] \quad (5)$$

Select a value of R5 to be approximately 10 kΩ. Slightly increasing or decreasing the value of R5 can result in closer output-voltage matching when using standard value resistors. In this design, R5 = 10.2 kΩ and R6 = 1.96 kΩ, resulting in a 4.96 V output voltage. The 51.1-Ω resistor, R4, is provided as a convenient location to break the control loop for stability testing.

9.2.2.3 Undervoltage Lockout Set Point

The undervoltage lockout (UVLO) can be adjusted using the external voltage divider network of R1 and R2. R1 is connected between the VIN and EN pins of the TPS54531 device and R2 is connected between the EN and GND pins. The UVLO has two thresholds, one for power up when the input voltage is rising and one for power down or brown outs when the input voltage is falling. For the design example, the minimum input voltage is 8 V. Therefore the start voltage threshold is set to 7 V with 2-V hysteresis. Use [Equation 1](#) and [Equation 2](#) to calculate the values for the upper and lower resistor values of R1 and R2.

9.2.2.4 Input Capacitors

The TPS54531 device requires an input decoupling capacitor and, depending on the application, a bulk input capacitor. The typical recommended value for the decoupling capacitor is 10 μF. A high-quality ceramic type X5R or X7R is recommended. The voltage rating should be greater than the maximum input voltage. A smaller value can be used as long as all other requirements are met; however 10 μF has been shown to work well in a wide variety of circuits. Additionally, some bulk capacitance may be required, especially if the TPS54531 circuit is not located within about 2 inches from the input voltage source. The value for this capacitor is not critical but should be rated to handle the maximum input voltage including ripple voltage, and should filter the output so that input ripple voltage is acceptable. For this design two 4.7-μF capacitors are used for the input decoupling capacitor. The capacitors are X7R dielectric rated for 50 V. The equivalent series resistance (ESR) is approximately 2 mΩ and the current rating is 3 A. Additionally, a small 0.01 μF capacitor is included for high frequency filtering.

Use [Equation 6](#) to calculate the input ripple voltage.

$$\Delta V_{\text{IN}} = \frac{I_{\text{O(MAX)}} \times 0.25}{C_{\text{BULK}} \times f_{\text{SW}}} + (I_{\text{O(MAX)}} \times \text{ESR}_{\text{MAX}})$$

where

- $I_{\text{O(MAX)}}$ is the maximum load current
 - C_{BULK} is the bulk capacitor value
 - f_{SW} is the switching frequency
 - ESR_{MAX} is the maximum series resistance of the bulk capacitor
- (6)

The maximum RMS ripple current must also be checked. For worst case conditions, use [Equation 7](#) to calculate the maximum-RMS input ripple current, $I_{CIN(RMS)}$.

$$I_{CIN(RMS)} = \frac{I_{O(MAX)}}{2} \quad (7)$$

In this case, the input ripple voltage is 243 mV and the RMS ripple current is 2.5 A.

NOTE

The actual input voltage ripple is greatly affected by parasitics associated with the layout and the output impedance of the voltage source.

The actual input voltage ripple for this circuit is listed in [Table 2](#) and is larger than the calculated value. This measured value is still below the specified input limit of 300 mV. The maximum voltage across the input capacitors would be $V_{IN(MAX)} + \Delta V_{IN} / 2$. The selected bulk and bypass capacitors are each rated for 50 V and the ripple current capacity is greater than 3 A, both providing ample margin. The maximum ratings for voltage and current must not be exceeded under any circumstance.

9.2.2.5 Output Filter Components

Two components must be selected for the output filter, L_{OUT} and C_{OUT} . Because the TPS54531 is an externally compensated device, a wide range of filter component types and values can be supported.

9.2.2.5.1 Inductor Selection

To calculate the minimum value of the output inductor, use [Equation 8](#)

$$L_{MIN} = \frac{V_{OUT} \times (V_{IN(MAX)} - V_{OUT})}{V_{IN(MAX)} \times K_{IND} \times I_{OUT} \times f_{SW}}$$

where

- K_{IND} is a coefficient that represents the amount of inductor ripple current relative to the maximum output current (8)

In general, this value is at the discretion of the designer; however, the following guidelines may be used. For designs using low-ESR output capacitors such as ceramics, a value as high as $K_{IND} = 0.3$ may be used. When using higher ESR output capacitors, $K_{IND} = 0.2$ yields better results.

For this design example, use $K_{IND} = 0.3$ and the minimum inductor value is calculated as 4.8 μ H. For this design, a close, standard value was chosen: 4.7 μ H.

For the output filter inductor, do not exceed the RMS current and saturation current ratings. Use [Equation 9](#) to calculate the inductor ripple current (I_{ripple}).

$$I_{ripple} = \frac{V_{OUT} \times (V_{IN(MAX)} - V_{OUT})}{V_{IN(MAX)} \times L_{OUT} \times f_{SW} \times 0.8} \quad (9)$$

Use [Equation 10](#) to calculate the RMS inductor current.

$$I_{L(RMS)} = \sqrt{I_{O(MAX)}^2 + \frac{1}{12} \times \left(\frac{V_{OUT} \times (V_{IN(MAX)} - V_{OUT})}{V_{IN(MAX)} \times L_{OUT} \times f_{SW} \times 0.8} \right)^2} \quad (10)$$

Use [Equation 11](#) to calculate the peak inductor current.

$$I_{L(PK)} = I_{O(MAX)} + \frac{V_{OUT} \times (V_{IN(MAX)} - V_{OUT})}{1.6 \times V_{IN(MAX)} \times L_{OUT} \times f_{SW}} \quad (11)$$

For this design, the RMS inductor current is 5.03 A and the peak inductor current is 5.96 A. The selected inductor is a Würth 4.7 μH . This inductor has a saturation current rating of 19 A and an RMS current rating of 7 A, which meets these requirements. Smaller or larger inductor values can be used depending on the amount of ripple current the designer wants to allow, so long as the other design requirements are met. Larger value inductors have lower AC current and result in lower output voltage ripple, while smaller inductor values will increase AC current and output voltage ripple. In general, inductor values for use with the TPS54531 device are in the range of 1 μH to 47 μH .

9.2.2.5.2 Capacitor Selection

Selecting the value of the output capacitor is based on three primary considerations. The output capacitor determines the modulator pole, the output voltage ripple, and how the regulator responds to a large change in load current. The output capacitance must be selected based on the more stringent of these three criteria.

The desired response to a large change in the load current is the first criteria. The output capacitor must supply the load with current when the regulator can not. This situation occurs if desired hold-up times occur for the regulator where the output capacitor must hold the output voltage above a certain level for a specified amount of time after the input power is removed. The regulator is also temporarily not able to supply sufficient output current if a large, fast increase occurs in the current needs of the load, such as a transition from no load to full load. The regulator usually requires two or more clock cycles for the control loop to respond to the change in load current and output voltage and adjust the duty cycle to react to the change. The output capacitor must be sized to supply the extra current to the load until the control loop responds to the load change. The output capacitance must be large enough to supply the difference in current for 2 clock cycles while only allowing a tolerable amount of drop in the output voltage. Use Equation 12 to calculate minimum output capacitance (C_O) required in this case.

$$C_O > \frac{2 \times \Delta I_{OUT}}{f_{SW} \times \Delta V_{OUT}}$$

where

- ΔI_{OUT} is the change in output current
 - f_{SW} is the switching frequency of the regulator
 - ΔV_{OUT} is the allowable change in the output voltage
- (12)

For this example, the transient load response is specified as a 5% change in V_{OUT} for a load step of 2.5 A. For this example, $\Delta I_{OUT} = 2.5$ A and $\Delta V_{OUT} = 0.05 \times 5 = 0.25$ V. Using these values results in a minimum capacitance of 35 μF . This value does not consider the ESR of the output capacitor in the output voltage change. For ceramic capacitors, the ESR is usually small enough to ignore in this calculation.

Use Equation 13 to calculate the minimum output capacitance needed to meet the output voltage ripple specification. In this case, the maximum output voltage ripple is 30 mV. Under this requirement Equation 13, yields 14 μF .

$$C_O > \frac{1}{8 \times f_{SW}} \times \frac{1}{\frac{V_{OUT\text{ripple}}}{I_{\text{ripple}}}}$$

where

- f_{SW} is the switching frequency
 - $V_{OUT\text{ripple}}$ is the maximum allowable output voltage ripple
 - I_{ripple} is the inductor ripple current
- (13)

Use Equation 14 to calculate the maximum ESR an output capacitor can have to meet the output-voltage ripple specification. Equation 14 indicates the ESR should be less than 15.6 m Ω . In this case, the ESR of the ceramic capacitor is much smaller than 15.6 m Ω .

$$R_{ESR} < \frac{V_{OUT\text{ripple}}}{I_{\text{ripple}}}$$
(14)

Additional capacitance deratings for aging, temperature, and DC bias should be considered which increases this minimum value. For this example, two 47- μ F 10-V X5R ceramic capacitors with 3 m Ω of ESR are used. Capacitors generally have limits to the amount of ripple current they can handle without failing or producing excess heat. An output capacitor that can support the inductor ripple current must be specified. Some capacitor data sheets specify the RMS (root mean square) value of the maximum ripple current. Use Equation 15 to calculate the RMS ripple current that the output capacitor must support. For this application, Equation 15 yields 554 mA.

$$I_{COUT(RMS)} = \frac{1}{\sqrt{12}} \times \left(\frac{V_{OUT} \times (V_{IN(MAX)} - V_{OUT})}{V_{IN(MAX)} \times L_{OUT} \times f_{SW} \times N_C} \right) \quad (15)$$

9.2.2.6 Compensation Components

Several possible methods exist to design closed loop compensation for DC-DC converters. For the ideal current mode control, the design equations can be easily simplified. The power stage gain is constant at low frequencies, and rolls off at -20 dB/decade above the modulator pole frequency. The power stage phase is 0 degrees at low frequencies and begins to fall one decade below the modulator pole frequency reaching a minimum of -90 degrees one decade above the modulator pole frequency. Use Equation 16 to calculate the modulator pole frequency.

$$f_{p_mod} = \frac{I_{O(MAX)}}{2\pi \times V_{OUT} \times C_{OUT}} \quad (16)$$

For the TPS54531 device, most circuits have relatively high amounts of slope compensation. As more slope compensation is applied, the power stage characteristics deviate from the ideal approximations. The phase loss of the power stage will now approach -180 degrees, making compensation more difficult. The power stage transfer function can be solved but it requires a tedious calculation. Use the PSpice model to accurately model the power-stage gain and phase so that a reliable compensation circuit can be designed. Alternately, a direct measurement of the power stage characteristics can be used. That is the technique used in this design procedure. For this design, the calculate values are as follows:

- L1 = 4.7 μ H
- C8 and C9 = 47 μ F (each)
- ESR = 3 m Ω

Figure 11 shows the power stage characteristics.

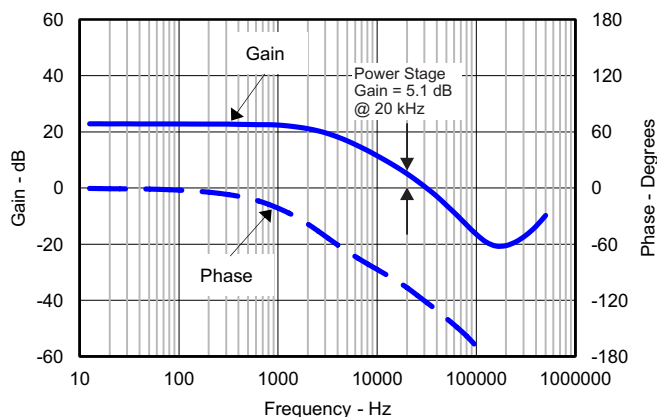

Figure 11. Power Stage Gain and Phase Characteristics

For this design, the intended crossover frequency is 20 kHz. From the power stage gain and phase plots, the gain at 20 kHz is 5.1 dB and the phase is about -100 degrees. For 60 degrees of phase margin, additional phase boost from a feed-forward capacitor in parallel with the upper resistor of the voltage set point divider is not needed. R3 sets the gain of the compensated error amplifier to be equal and opposite the power stage gain at crossover. Use Equation 17 to calculate the required value of R3.

$$R3 = \frac{10^{-\frac{G_{PWRSTG}}{20}}}{g_{m_{ea}}} \times \frac{V_{OUT}}{V_{ref}} \quad (17)$$

To maximize phase gain, the compensator zero is placed one decade below the crossover frequency of 20 kHz. Use [Equation 18](#) to calculate the required value for C6.

$$C6 = \frac{1}{2 \cdot \pi \cdot R3 \cdot \frac{F_{CO}}{10}} \quad (18)$$

To maximize phase gain the high frequency pole is placed one decade above the crossover frequency of 20 kHz. The pole can also be useful to offset the ESR of aluminum electrolytic output capacitors. Use [Equation 19](#) to calculate the value for C7.

$$C7 = \frac{1}{2 \cdot \pi \cdot R3 \cdot 10 \cdot F_{CO}} \quad (19)$$

For this design, the calculated values are as follows:

$$R3 = 37.4 \text{ k}\Omega$$

$$C6 = 2200 \text{ pF}$$

$$C7 = 22 \text{ pF}$$

9.2.2.7 Bootstrap Capacitor

Every TPS54531 design requires a bootstrap capacitor, C4. The bootstrap capacitor value must be 0.1 μF . The bootstrap capacitor is located between the PH and BOOT pins. The bootstrap capacitor should be a high-quality ceramic type with X7R or X5R grade dielectric for temperature stability.

9.2.2.8 Catch Diode

The TPS54531 device is designed to operate using an external catch diode between the PH and GND pins. The selected diode must meet the absolute maximum ratings for the application. The reverse voltage must be higher than the maximum voltage at the PH pin, which is $V_{IN(MAX)} + 0.5 \text{ V}$. Peak current must be greater than $I_{O(MAX)}$ plus one-half the peak-to-peak inductor current. The forward-voltage drop should be small for higher efficiencies. The catch diode conduction time is (typically) longer than the high-side FET on time, so attention paid to diode parameters can make a marked improvement in overall efficiency. Additionally, check that the selected device is capable of dissipating the power losses. For this design, a CDBC540-G was selected, with a reverse voltage of 40 V, forward current of 5 A, and a forward-voltage drop of 0.55 V.

9.2.2.9 Slow-Start Capacitor

The slow-start capacitor determines the minimum amount of time required for the output voltage to reach the nominal programmed value during power up which is useful if a load requires a controlled voltage slew rate. The slow-start capacitor is also used if the output capacitance is very large and requires large amounts of current to quickly charge the capacitor to the output voltage level. The large currents necessary to charge the capacitor may make the TPS54531 device reach the current limit. Excessive current draw from the input power supply may cause the input voltage rail to sag. Limiting the output voltage slew rate solves both of these problems. Use [Equation 3](#) to calculate the value of the slow-start capacitor. For the example circuit, the slow-start time is not too critical because the output capacitor value is $2 \times 47 \mu\text{F}$ which does not require much current to charge to 5 V. The example circuit has the slow-start time set to an arbitrary value of 4 ms which requires a 10-nF capacitor. For the TPS54531 device, I_{SS} is 2 μA and V_{ref} is 0.8 V.

9.2.2.10 Output Voltage Limitations

Because of the internal design of the TPS54531 device, any given voltage has both upper and lower output voltage limits for any given input voltage. The upper limit of the output-voltage set point is constrained by the maximum duty cycle of 91% and is calculated with [Equation 20](#). The equation assumes the maximum ON resistance for the internal high-side FET.

$$V_{O(MAX)} = 0.91 \times \left((V_{IN(MIN)} - I_{O(MAX)} \times R_{DS(on)max}) + V_D \right) - (I_{O(MAX)} \times R_L) - V_D$$

where

- $V_{IN(MIN)}$ = Minimum input voltage
 - $I_{O(MAX)}$ = Maximum load current
 - V_D = Catch diode forward voltage
 - R_L = Output inductor series resistance
- (20)

The lower limit is constrained by the minimum controllable on time which may be as high as 130 ns. The approximate minimum output voltage for a given input voltage and minimum load current is given by [Equation 21](#).

$$V_{O(MIN)} = 0.089 \times \left((V_{IN(MAX)} - I_{O(MIN)} \times R_{DS(on)min}) + V_D \right) - (I_{O(MIN)} \times R_L) - V_D$$

where

- $V_{IN(MAX)}$ = Maximum input voltage
 - $I_{O(MIN)}$ = Minimum load current
 - V_D = Catch diode forward voltage
 - R_L = Output inductor series resistance
- (21)

This equation assumes nominal on-resistance for the high-side FET and accounts for worst case variation of operating frequency set point. Any design operating near the operational limits of the device should be carefully checked to ensure proper functionality.

9.2.2.11 Power Dissipation Estimate

The following formulas show how to estimate the device power dissipation under continuous-conduction mode (CCM) operations. These formulas should not be used if the device is working in the discontinuous-conduction mode (DCM) or pulse-skipping Eco-mode™.

The device power dissipation includes:

1. Conduction loss:

$$P_{con} = I_{OUT}^2 \times R_{DS(on)} \times V_{OUT} / V_{IN}$$

where

- I_{OUT} is the output current (A)
- $R_{DS(on)}$ is the on-resistance of the high-side MOSFET (Ω)
- V_{OUT} is the output voltage (V)
- V_{IN} is the input voltage (V)

2. Switching loss:

$$P_{sw} = 0.5 \times 10^{-9} \times V_{IN}^2 \times I_{OUT} \times f_{sw}$$

where

- f_{sw} is the switching frequency (Hz)

3. Gate charge loss:

$$P_{gc} = 22.8 \times 10^{-9} \times f_{sw}$$

4. Quiescent current loss:

$$P_q = 0.11 \times 10^{-3} \times V_{IN}$$

Therefore:

$$P_{tot} = P_{con} + P_{sw} + P_{gc} + P_q$$

where

- P_{tot} is the total device power dissipation (W)

For given T_A :

$$T_J = T_A + R_{th} \times P_{tot}$$

where

- T_J is the junction temperature (°C)
- T_A is the ambient temperature (°C)
- R_{th} is the thermal resistance of the package (°C/W)

For given $T_{JMAX} = 150^\circ\text{C}$:

$$T_{AMAX} = T_{JMAX} - R_{th} \times P_{tot}$$

where

- T_{JMAX} is maximum junction temperature (°C)
- T_{AMAX} is maximum ambient temperature (°C)

9.2.3 Application Curves

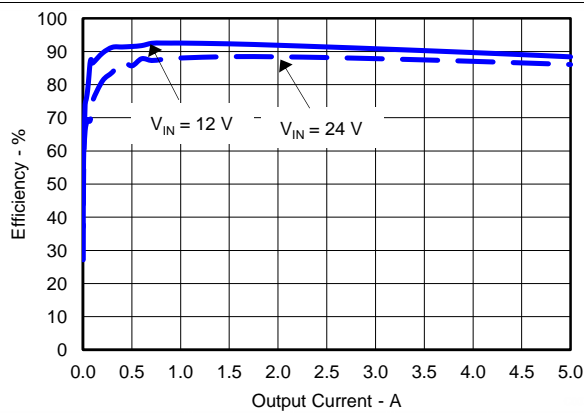

Figure 12. Efficiency

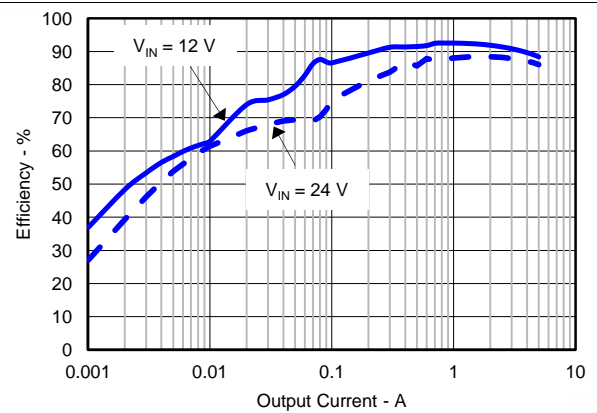

Figure 13. Low-Current Efficiency

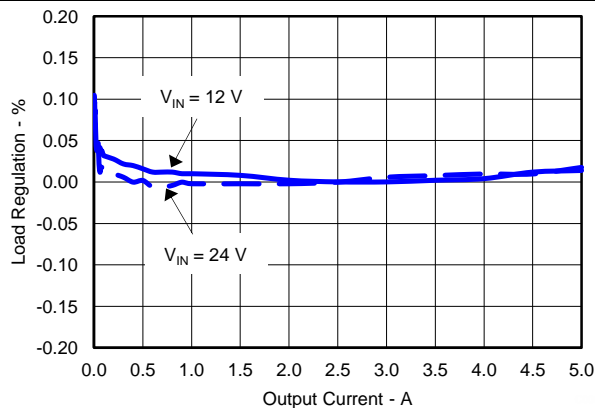

Figure 14. Load Regulation

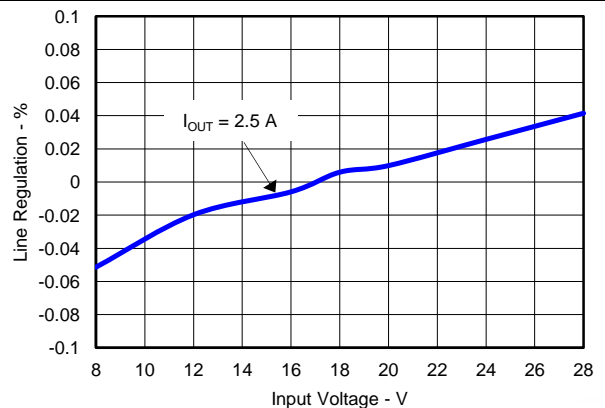

Figure 15. Line Regulation

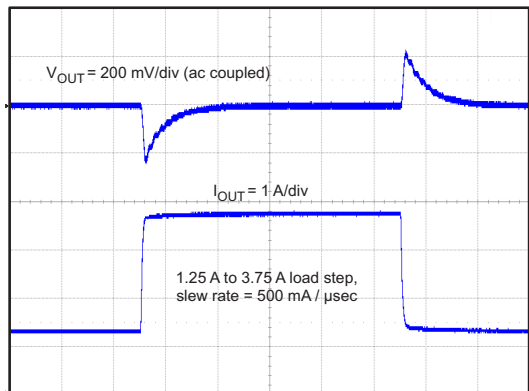

Figure 16. Transient Response

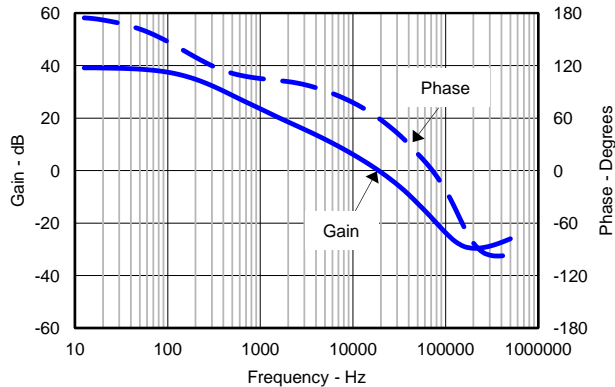

Figure 17. Loop Response

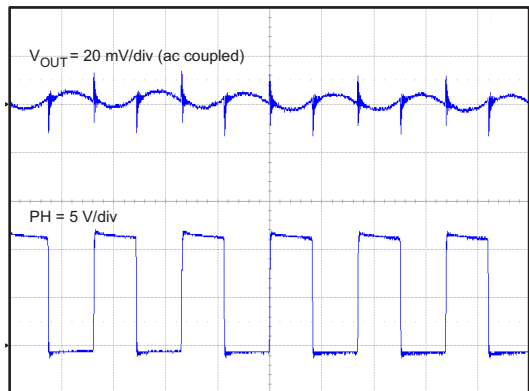

Figure 18. Full-Load Output Ripple

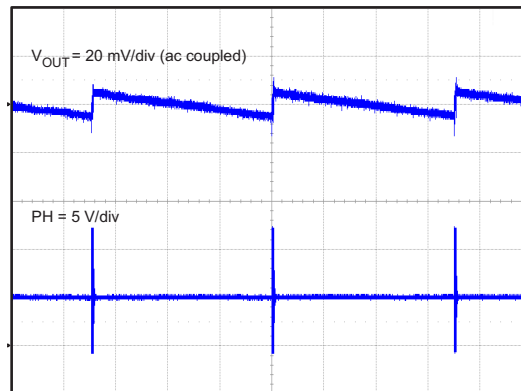

Figure 19. Eco-mode Output Ripple

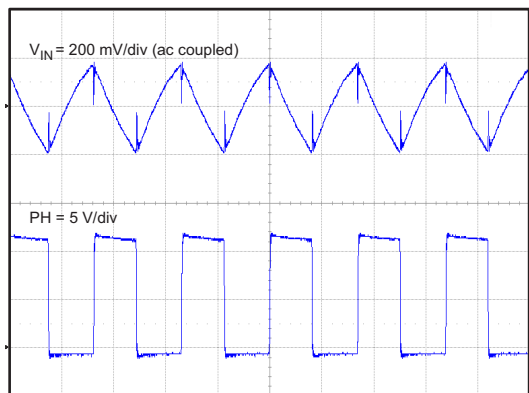

Figure 20. Full-Load Input Ripple

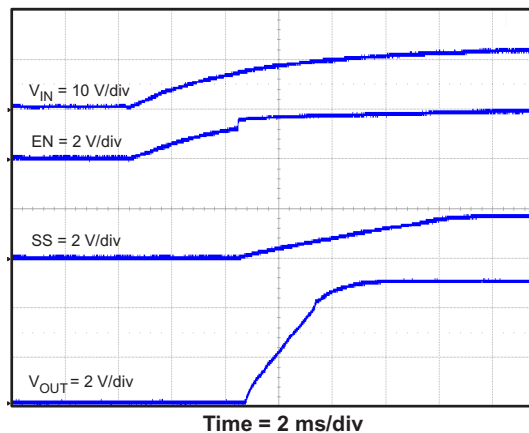
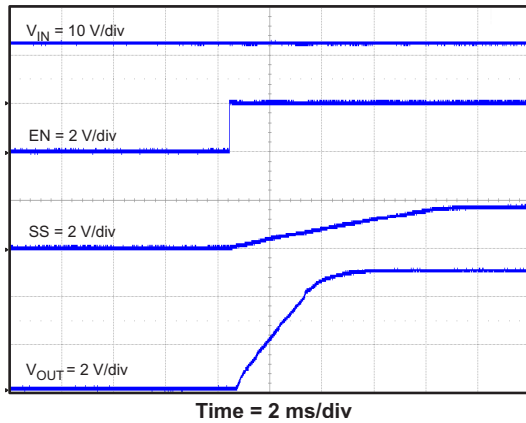
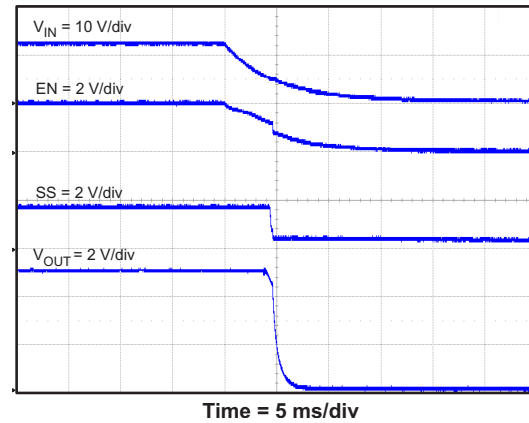
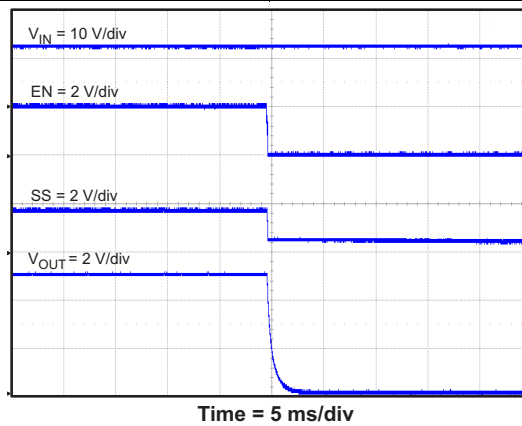

Figure 21. Startup Relative to VIN

Figure 22. Startup Relative to Enable

Figure 23. Shut Down Relative to VIN

Figure 24. Shut Down Relative to EN

10 Power Supply Recommendations

The device is designed to operate from an input-voltage supply range between 3.5 V and 28 V. This input supply should be well regulated. If the input supply is located more than a few inches from the converter additional bulk capacitance may be required in addition to the ceramic bypass capacitors. An electrolytic capacitor with a value of 100 μ F is a typical choice.

11 Layout

11.1 Layout Guidelines

The VIN pin should be bypassed to ground with a low-ESR ceramic bypass capacitor. Care should be taken to minimize the loop area formed by the bypass capacitor connections, the VIN pin, and the anode of the catch diode. The typical recommended bypass capacitance is 10- μ F ceramic with a X5R or X7R dielectric and the optimum placement is closest to the VIN pins and the source of the anode of the catch diode. [Figure 25](#) shows a PCB layout example. The GND pin should be tied to the PCB ground plane at the pin of the device. The PH pin should be routed to the cathode of the catch diode and to the output inductor. Because the PH connection is the switching node, the catch diode and output inductor should be located very close to the PH pins, and the area of the PCB conductor minimized to prevent excessive capacitive coupling. For operation at full rated load, the exposed thermal pad should be soldered directly to the top-side ground area under the device. Use thermal vias

Layout Guidelines (continued)

to connect the top-side ground area to an internal or bottom-layer ground plane. The total copper area must provide adequate heat dissipation. Additional vias adjacent to the device can be used to improve heat transfer to the internal or bottom-layer ground plane. The additional external components can be placed approximately as shown. Obtaining acceptable performance with alternate layout schemes may be possible, however this layout has been shown to produce good results and is intended as a guideline.

11.2 Layout Example

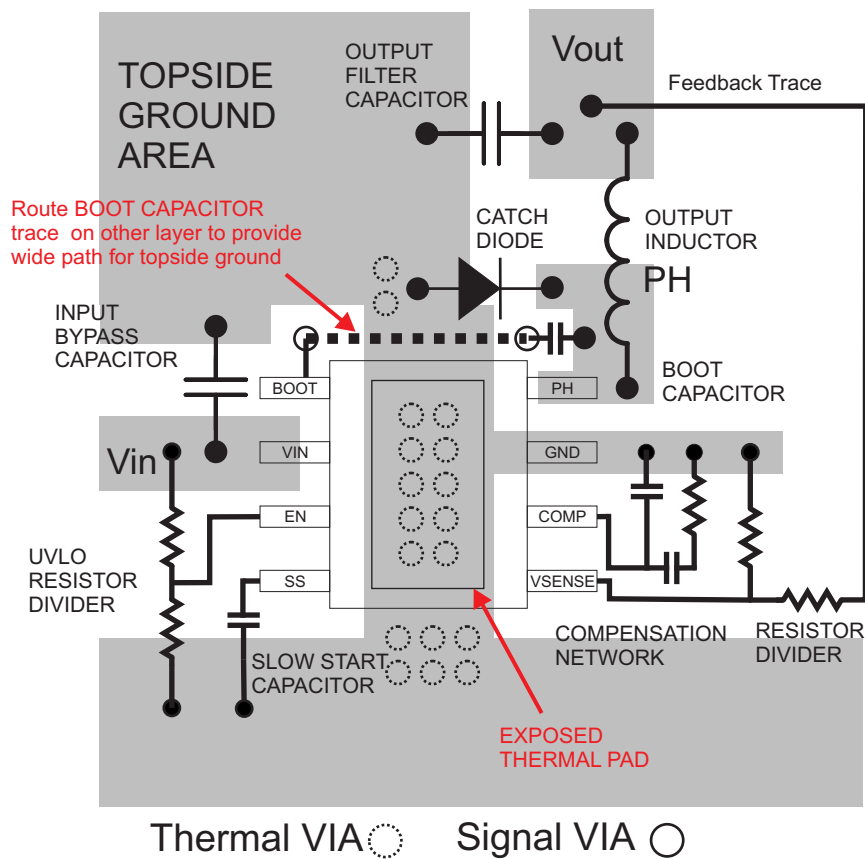

Figure 25. TPS54531DDA Board Layout

11.3 Electromagnetic Interference (EMI) Considerations

As EMI becomes a rising concern in more and more applications, the internal design of the TPS54531 device includes features to reduce the EMI. The high-side MOSFET gate drive is designed to reduce the PH pin voltage ringing. The internal IC rails are isolated to decrease the noise sensitivity. A package bond wire scheme is used to lower the parasitics effects.

To achieve the best EMI performance, external component selection and board layout are equally important. Follow the steps listed in the [Detailed Design Procedure](#) section to prevent potential EMI issues.

12 Device and Documentation Support

12.1 Device Support

12.1.1 Development Support

For the WEBENCH Software Tool, go to www.TI.com/WEBENCH.

12.2 Trademarks

Eco-mode, PowerPAD are trademarks of Texas Instruments.
WEBENCH is a registered trademark of Texas Instruments.
All other trademarks are the property of their respective owners.

12.3 Electrostatic Discharge Caution



These devices have limited built-in ESD protection. The leads should be shorted together or the device placed in conductive foam during storage or handling to prevent electrostatic damage to the MOS gates.

12.4 Glossary

[SLYZ022](#) — *TI Glossary*.

This glossary lists and explains terms, acronyms, and definitions.

13 Mechanical, Packaging, and Orderable Information

The following pages include mechanical, packaging, and orderable information. This information is the most current data available for the designated devices. This data is subject to change without notice and revision of this document. For browser-based versions of this data sheet, refer to the left-hand navigation.

PACKAGING INFORMATION

Orderable Device	Status (1)	Package Type	Package Drawing	Pins	Package Qty	Eco Plan (2)	Lead/Ball Finish (6)	MSL Peak Temp (3)	Op Temp (°C)	Device Marking (4/5)	Samples
TPS54531DDA	ACTIVE	SO PowerPAD	DDA	8	75	Green (RoHS & no Sb/Br)	CU NIPDAUAG	Level-2-260C-1 YEAR	-40 to 85	54531	Samples
TPS54531DDAR	ACTIVE	SO PowerPAD	DDA	8	2500	Green (RoHS & no Sb/Br)	CU NIPDAUAG	Level-2-260C-1 YEAR	-40 to 85	54531	Samples

(1) The marketing status values are defined as follows:

ACTIVE: Product device recommended for new designs.

LIFEBUY: TI has announced that the device will be discontinued, and a lifetime-buy period is in effect.

NRND: Not recommended for new designs. Device is in production to support existing customers, but TI does not recommend using this part in a new design.

PREVIEW: Device has been announced but is not in production. Samples may or may not be available.

OBSOLETE: TI has discontinued the production of the device.

(2) Eco Plan - The planned eco-friendly classification: Pb-Free (RoHS), Pb-Free (RoHS Exempt), or Green (RoHS & no Sb/Br) - please check <http://www.ti.com/productcontent> for the latest availability information and additional product content details.

TBD: The Pb-Free/Green conversion plan has not been defined.

Pb-Free (RoHS): TI's terms "Lead-Free" or "Pb-Free" mean semiconductor products that are compatible with the current RoHS requirements for all 6 substances, including the requirement that lead not exceed 0.1% by weight in homogeneous materials. Where designed to be soldered at high temperatures, TI Pb-Free products are suitable for use in specified lead-free processes.

Pb-Free (RoHS Exempt): This component has a RoHS exemption for either 1) lead-based flip-chip solder bumps used between the die and package, or 2) lead-based die adhesive used between the die and leadframe. The component is otherwise considered Pb-Free (RoHS compatible) as defined above.

Green (RoHS & no Sb/Br): TI defines "Green" to mean Pb-Free (RoHS compatible), and free of Bromine (Br) and Antimony (Sb) based flame retardants (Br or Sb do not exceed 0.1% by weight in homogeneous material)

(3) MSL, Peak Temp. - The Moisture Sensitivity Level rating according to the JEDEC industry standard classifications, and peak solder temperature.

(4) There may be additional marking, which relates to the logo, the lot trace code information, or the environmental category on the device.

(5) Multiple Device Markings will be inside parentheses. Only one Device Marking contained in parentheses and separated by a "~" will appear on a device. If a line is indented then it is a continuation of the previous line and the two combined represent the entire Device Marking for that device.

(6) Lead/Ball Finish - Orderable Devices may have multiple material finish options. Finish options are separated by a vertical ruled line. Lead/Ball Finish values may wrap to two lines if the finish value exceeds the maximum column width.

Important Information and Disclaimer: The information provided on this page represents TI's knowledge and belief as of the date that it is provided. TI bases its knowledge and belief on information provided by third parties, and makes no representation or warranty as to the accuracy of such information. Efforts are underway to better integrate information from third parties. TI has taken and continues to take reasonable steps to provide representative and accurate information but may not have conducted destructive testing or chemical analysis on incoming materials and chemicals. TI and TI suppliers consider certain information to be proprietary, and thus CAS numbers and other limited information may not be available for release.

In no event shall TI's liability arising out of such information exceed the total purchase price of the TI part(s) at issue in this document sold by TI to Customer on an annual basis.

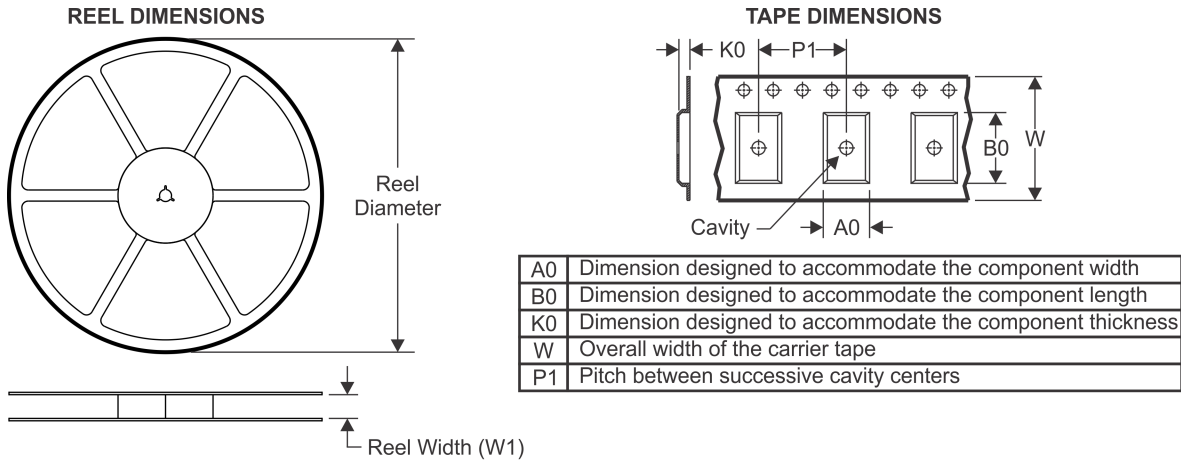
TAPE AND REEL INFORMATION

QUADRANT ASSIGNMENTS FOR PIN 1 ORIENTATION IN TAPE

*All dimensions are nominal

Device	Package Type	Package Drawing	Pins	SPQ	Reel Diameter (mm)	Reel Width W1 (mm)	A0 (mm)	B0 (mm)	K0 (mm)	P1 (mm)	W (mm)	Pin1 Quadrant
TPS54531DDAR	SO Power PAD	DDA	8	2500	330.0	12.8	6.4	5.2	2.1	8.0	12.0	Q1

TAPE AND REEL BOX DIMENSIONS



*All dimensions are nominal

Device	Package Type	Package Drawing	Pins	SPQ	Length (mm)	Width (mm)	Height (mm)
TPS54531DDAR	SO PowerPAD	DDA	8	2500	364.0	364.0	27.0



Images above are just a representation of the package family, actual package may vary.
Refer to the product data sheet for package details.

DDA (R-PDSO-G8)

PowerPAD™ PLASTIC SMALL OUTLINE

THERMAL INFORMATION

This PowerPAD™ package incorporates an exposed thermal pad that is designed to be attached to a printed circuit board (PCB). The thermal pad must be soldered directly to the PCB. After soldering, the PCB can be used as a heatsink. In addition, through the use of thermal vias, the thermal pad can be attached directly to the appropriate copper plane shown in the electrical schematic for the device, or alternatively, can be attached to a special heatsink structure designed into the PCB. This design optimizes the heat transfer from the integrated circuit (IC).

For additional information on the PowerPAD package and how to take advantage of its heat dissipating abilities, refer to Technical Brief, PowerPAD Thermally Enhanced Package, Texas Instruments Literature No. SLMA002 and Application Brief, PowerPAD Made Easy, Texas Instruments Literature No. SLMA004. Both documents are available at www.ti.com.

The exposed thermal pad dimensions for this package are shown in the following illustration.



Exposed Thermal Pad Dimensions

4206322-6/L 05/12

NOTE: A. All linear dimensions are in millimeters

PowerPAD is a trademark of Texas Instruments



- NOTES:
- A. All linear dimensions are in millimeters.
 - B. This drawing is subject to change without notice.
 - C. Publication IPC-7351 is recommended for alternate designs.
 - D. This package is designed to be soldered to a thermal pad on the board. Refer to Technical Brief, PowerPad Thermally Enhanced Package, Texas Instruments Literature No. SLMA002, SLMA004, and also the Product Data Sheets for specific thermal information, via requirements, and recommended board layout. These documents are available at www.ti.com <<http://www.ti.com>>. Publication IPC-7351 is recommended for alternate designs.
 - E. Laser cutting apertures with trapezoidal walls and also rounding corners will offer better paste release. Customers should contact their board assembly site for stencil design recommendations. Example stencil design based on a 50% volumetric metal load solder paste. Refer to IPC-7525 for other stencil recommendations.
 - F. Customers should contact their board fabrication site for solder mask tolerances between and around signal pads.

PowerPAD is a trademark of Texas Instruments.

IMPORTANT NOTICE

Texas Instruments Incorporated (TI) reserves the right to make corrections, enhancements, improvements and other changes to its semiconductor products and services per JESD46, latest issue, and to discontinue any product or service per JESD48, latest issue. Buyers should obtain the latest relevant information before placing orders and should verify that such information is current and complete.

TI's published terms of sale for semiconductor products (<http://www.ti.com/sc/docs/stdterms.htm>) apply to the sale of packaged integrated circuit products that TI has qualified and released to market. Additional terms may apply to the use or sale of other types of TI products and services.

Reproduction of significant portions of TI information in TI data sheets is permissible only if reproduction is without alteration and is accompanied by all associated warranties, conditions, limitations, and notices. TI is not responsible or liable for such reproduced documentation. Information of third parties may be subject to additional restrictions. Resale of TI products or services with statements different from or beyond the parameters stated by TI for that product or service voids all express and any implied warranties for the associated TI product or service and is an unfair and deceptive business practice. TI is not responsible or liable for any such statements.

Buyers and others who are developing systems that incorporate TI products (collectively, "Designers") understand and agree that Designers remain responsible for using their independent analysis, evaluation and judgment in designing their applications and that Designers have full and exclusive responsibility to assure the safety of Designers' applications and compliance of their applications (and of all TI products used in or for Designers' applications) with all applicable regulations, laws and other applicable requirements. Designer represents that, with respect to their applications, Designer has all the necessary expertise to create and implement safeguards that (1) anticipate dangerous consequences of failures, (2) monitor failures and their consequences, and (3) lessen the likelihood of failures that might cause harm and take appropriate actions. Designer agrees that prior to using or distributing any applications that include TI products, Designer will thoroughly test such applications and the functionality of such TI products as used in such applications.

TI's provision of technical, application or other design advice, quality characterization, reliability data or other services or information, including, but not limited to, reference designs and materials relating to evaluation modules, (collectively, "TI Resources") are intended to assist designers who are developing applications that incorporate TI products; by downloading, accessing or using TI Resources in any way, Designer (individually or, if Designer is acting on behalf of a company, Designer's company) agrees to use any particular TI Resource solely for this purpose and subject to the terms of this Notice.

TI's provision of TI Resources does not expand or otherwise alter TI's applicable published warranties or warranty disclaimers for TI products, and no additional obligations or liabilities arise from TI providing such TI Resources. TI reserves the right to make corrections, enhancements, improvements and other changes to its TI Resources. TI has not conducted any testing other than that specifically described in the published documentation for a particular TI Resource.

Designer is authorized to use, copy and modify any individual TI Resource only in connection with the development of applications that include the TI product(s) identified in such TI Resource. NO OTHER LICENSE, EXPRESS OR IMPLIED, BY ESTOPPEL OR OTHERWISE TO ANY OTHER TI INTELLECTUAL PROPERTY RIGHT, AND NO LICENSE TO ANY TECHNOLOGY OR INTELLECTUAL PROPERTY RIGHT OF TI OR ANY THIRD PARTY IS GRANTED HEREIN, including but not limited to any patent right, copyright, mask work right, or other intellectual property right relating to any combination, machine, or process in which TI products or services are used. Information regarding or referencing third-party products or services does not constitute a license to use such products or services, or a warranty or endorsement thereof. Use of TI Resources may require a license from a third party under the patents or other intellectual property of the third party, or a license from TI under the patents or other intellectual property of TI.

TI RESOURCES ARE PROVIDED "AS IS" AND WITH ALL FAULTS. TI DISCLAIMS ALL OTHER WARRANTIES OR REPRESENTATIONS, EXPRESS OR IMPLIED, REGARDING RESOURCES OR USE THEREOF, INCLUDING BUT NOT LIMITED TO ACCURACY OR COMPLETENESS, TITLE, ANY EPIDEMIC FAILURE WARRANTY AND ANY IMPLIED WARRANTIES OF MERCHANTABILITY, FITNESS FOR A PARTICULAR PURPOSE, AND NON-INFRINGEMENT OF ANY THIRD PARTY INTELLECTUAL PROPERTY RIGHTS. TI SHALL NOT BE LIABLE FOR AND SHALL NOT DEFEND OR INDEMNIFY DESIGNER AGAINST ANY CLAIM, INCLUDING BUT NOT LIMITED TO ANY INFRINGEMENT CLAIM THAT RELATES TO OR IS BASED ON ANY COMBINATION OF PRODUCTS EVEN IF DESCRIBED IN TI RESOURCES OR OTHERWISE. IN NO EVENT SHALL TI BE LIABLE FOR ANY ACTUAL, DIRECT, SPECIAL, COLLATERAL, INDIRECT, PUNITIVE, INCIDENTAL, CONSEQUENTIAL OR EXEMPLARY DAMAGES IN CONNECTION WITH OR ARISING OUT OF TI RESOURCES OR USE THEREOF, AND REGARDLESS OF WHETHER TI HAS BEEN ADVISED OF THE POSSIBILITY OF SUCH DAMAGES.

Unless TI has explicitly designated an individual product as meeting the requirements of a particular industry standard (e.g., ISO/TS 16949 and ISO 26262), TI is not responsible for any failure to meet such industry standard requirements.

Where TI specifically promotes products as facilitating functional safety or as compliant with industry functional safety standards, such products are intended to help enable customers to design and create their own applications that meet applicable functional safety standards and requirements. Using products in an application does not by itself establish any safety features in the application. Designers must ensure compliance with safety-related requirements and standards applicable to their applications. Designer may not use any TI products in life-critical medical equipment unless authorized officers of the parties have executed a special contract specifically governing such use. Life-critical medical equipment is medical equipment where failure of such equipment would cause serious bodily injury or death (e.g., life support, pacemakers, defibrillators, heart pumps, neurostimulators, and implantables). Such equipment includes, without limitation, all medical devices identified by the U.S. Food and Drug Administration as Class III devices and equivalent classifications outside the U.S.

TI may expressly designate certain products as completing a particular qualification (e.g., Q100, Military Grade, or Enhanced Product). Designers agree that it has the necessary expertise to select the product with the appropriate qualification designation for their applications and that proper product selection is at Designers' own risk. Designers are solely responsible for compliance with all legal and regulatory requirements in connection with such selection.

Designer will fully indemnify TI and its representatives against any damages, costs, losses, and/or liabilities arising out of Designer's non-compliance with the terms and provisions of this Notice.