

Data sheet

Commercial Art.No.: 96.232.2034.1

Cable assembly RST20i3K1-S 15 20SW

RST20i3 connection cable male - free end, 3 pole, assembled with shrinkage tube, application 250V with PE, 16A, cable type H07RN-F, length 2.0m, cross section 1.5mm², coding color black



Commercial Art.No.	96.232.2034.1
EAN	4015573761933
Order Unit	1

Certificates / Approvals



Technical data

General

Rated current	16 A
Rated voltage	250 V
Rated impulse voltage	4 kV
Pollution degree	3
Lockable	self-locking (unlocking by tool)
Color of coding/ contact carrier	black
Marking of poles	L, N, PE
Color of housing inclusive strain relief	black

Model

type of construction	Shrinkage tube
Connection type	Crimp
Nominal cross section conductor	1.5 mm ²
Degree of protection (IP)	IP66/68 (3m;2h)
Wire strip length	9 mm
sheath strip length	35 mm
Preparation of conductor ends	ultrasonically compressed wire ends
Cable type	H07RN-F
Cable color	black
Cable diameter min.	9.6 mm
Cable diameter max.	10 mm
Version of cable	male - free end
Type of cord set	connection cable

Version cable end 1	free end
Version cable end 2	male
Shielded	No

Material

Surface finish	Silver-plated
halogen free	No
Continuous temperature of cable	60 °C
Insulation components continuous temperature	100 °C
Fire load	1.334 kWh

Dimensions

Total length	2 m
--------------	-----

Classification

ECLASS 11	
ECLASS 8.1	27440604
ETIM 7.0	EC002587
ETIM 6.0	EC002587
ETIM 5.0	EC002587
ETIM 4.0	EC002587

Note

Note	The total length may vary up to + / - 3 %.
------	--

Product compliance

ROHS conformity status	Compliant/Exempted
ROHS exceptions	III-6(c)
REACH-SVHC conformity status	Duty-To-Declare
REACH-SVHC substances	Lead
REACH-SVHC CAS numbers	7439-92-1

These dimensions will be especially checked at delivery
Only inspection dimensions
With /E marked dimensions are only valid for internal use

Diese Maße werden bei Abnahme besonders geprüft
Ausschließlich Prüfmaße
Mit /E gekennzeichnete Maße sind nur für interne Zwecke gültig

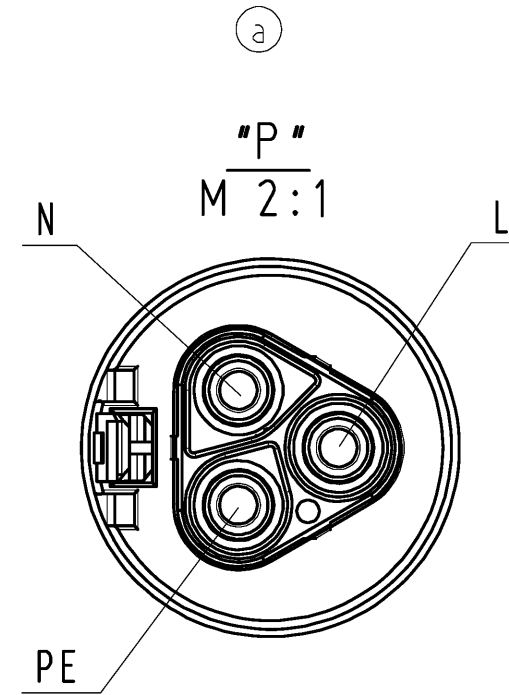
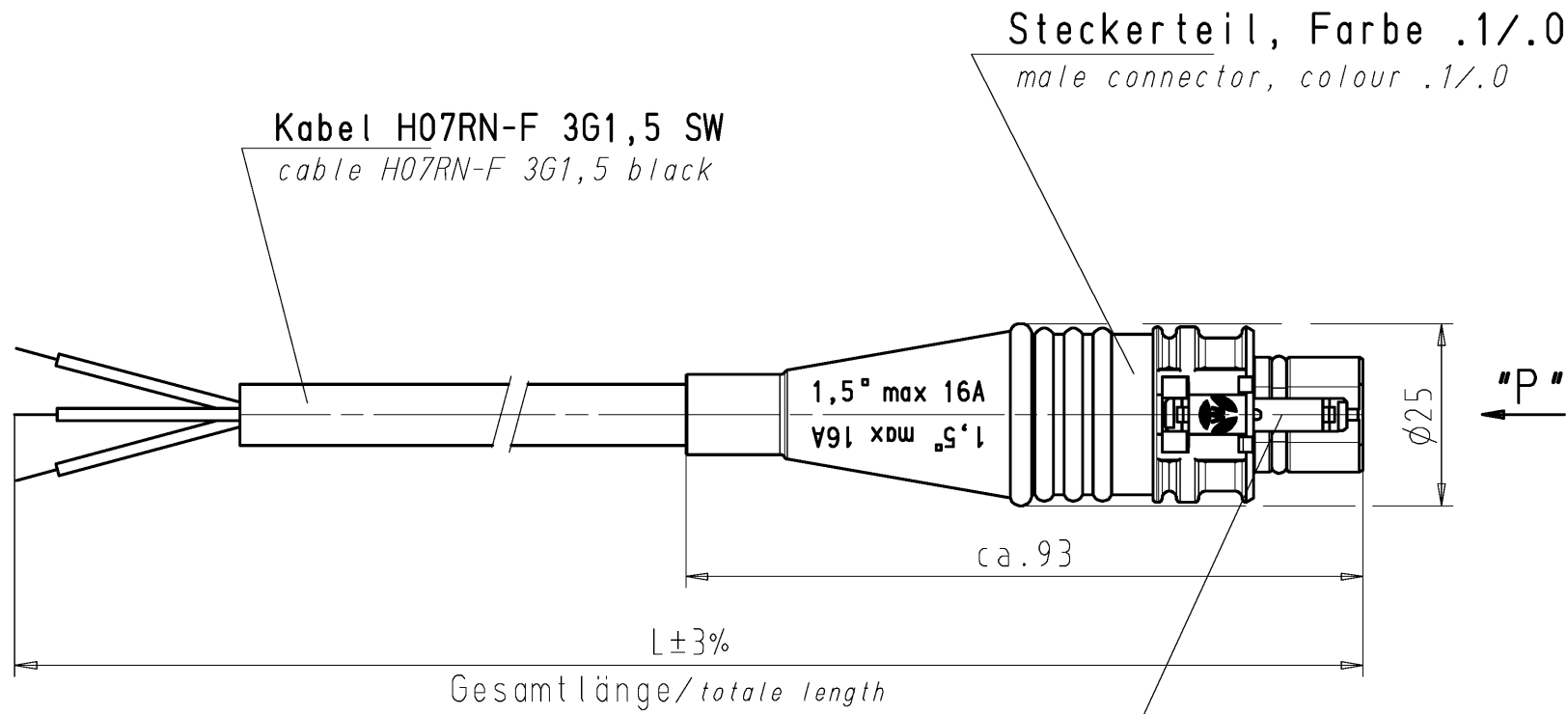

(a)

Weitere Daten siehe Katalog
further data see catalog

Farbe/colour	
schwarz/black	.1
lichtgrau/light grey	.0
betongrau/concrete grey	.3

Teile-Nr. part - no.	L	Beispiel (Farbe: schwarz, lichtgrau) example (colour: black, light grey)	Typ type
96.232.XX34.1	XX in dm-Schritten	96.232.1034.1 = 10dm/L= 1000mm	RST2013K1-S 15 10SW
96.232.XX34.0		96.232.1034.0	RST2013K1-S 15 10GL
U6.232.XX34.1	XX in m-Schritten	U6.232.1234.1 = 12 m/L=12000mm	RST2013K1-S 15 X12SW
U6.232.XX34.0		U6.232.1234.0	RST2013K1-S 15 X12GL

Tolerierung Size ISO 14405 (E)/Tolerance system Size ISO 14405 (E).
(This ISO-standard describes the envelope principle. According to the envelope principle the deviations of form and parallelism are limited by the size tolerances).
ja/yes Stoffverbots- und Deklarationsliste nach WN 5020.010 ist einzuhalten.
Conformity with Wieland document WN 5020.010 e (list of prohibited/declarable hazardous substances) to be declared!

Freitoleranz nach General tolerance CAD - Zeichnung, keine manuellen Änderungen CAD - drawing, no manual modifications allowed 1.Verwendung: First Use: Blatt: 1 von 1 Sheet: of 1

		Werkstoff/Material	2007	Tag/Date	Name	T	Zeichnung Nr./Drawing No.	Index
/	Maßstab/Scale		gezeichnet/drawn	22.02.	Kneitz			
/	x	Vol. mm ³ Of l./Surf. mm ²	geprüft/checked	-	-	Maße in mm/Dimensions are in mm		
/			Normgepr. Stand./check	-	-	Ersatz für/Replacement for: -		
a	15.10.2014/	wieland www.wieland-electric.com		Type	Benennung/Title			
Index	Datum / Blatt Date / Sheet			KONFEKT_LEITUNG freies Ende-Stecker Crimpausführung/free-end-male pre-assembled cable crimp design K1 250V				
Änderung/Revision								

Weitergabe sowie Vervielfältigung dieses Dokuments, Verwertung und Mitteilung seines Inhalts sind verboten, soweit nicht ausdrücklich gestattet.
The reproduction, distribution and utilization of this document as well as the communication of its contents to others without express authorization is prohibited.