

# 深圳市维拓精电科技有限公司

## WTL International Limited

### APPROVAL SHEET

|                         |                               |      |          |         |
|-------------------------|-------------------------------|------|----------|---------|
| DESCRIPTION :           | HC-49/SMD Crystal             |      |          |         |
| NOMINAL FREQ.:          | 7.37280MHz                    |      |          |         |
| WTL P/N:                | WTL9M85577FO                  |      |          |         |
| VERSION:                | 1                             |      |          |         |
| DATE:                   | 2023.04.18                    |      |          |         |
| Customer                | Customer P/N                  |      |          |         |
|                         | /                             |      |          |         |
| Customer Signature      | WTL                           |      |          |         |
|                         | Approved by: <i>Kevin Liu</i> |      |          |         |
|                         | Checked by: <i>Shu Ping</i>   |      |          |         |
|                         | Issued by: <i>Shengbiao</i>   |      |          |         |
| <b>REVISION HISTORY</b> |                               |      |          |         |
| Revised Page            | Revision Content              | Date | Ref. No. | Reviser |
|                         |                               |      |          |         |
|                         |                               |      |          |         |
|                         |                               |      |          |         |
|                         |                               |      |          |         |



## CONTENT CATALOG

|                            |      |
|----------------------------|------|
| APPROVAL SHEET             | P. 1 |
| CONTENT CATALOG            | P. 2 |
| ELECTRICAL SPECIFICATIONS  | P. 3 |
| DIMENSIONS                 | P. 4 |
| MARKING                    | P. 4 |
| STRUCTURE ILLUSTRATION     | P. 5 |
| RELIABILITY SPECIFICATIONS | P. 6 |
| SUGGESTED REFLOW PROFILE   | P. 6 |
| SUBSTANCES IN PRODUCT      | P. 7 |
| PACKING SPECIFICATIONS     | P. 8 |
| WTL PART NUMBER SYSTEM     | P. 9 |
|                            |      |
|                            |      |
|                            |      |
|                            |      |

Attachment(s):

- 1.Product Specification Sheet
- 2.Electrical Testing Report
- 3.Reliability Report
- 4.ICP Test Report (SGS)

**FEATURE**

- Height 4.0mm, compact unit for surface mount
- Able to by means of a metal case and completely sealed high solution characteristics
- Copes with high density mounting and is the optimum for mass production



**1、 ELECTRICAL SPECIFICATIONS**

|  |                              |
|--|------------------------------|
| Hold Style   | HC-49/SMD                    |
| Nominal Frequency  | 7.37280MHz                   |
| Modew  | Fundamental / AT             |
| Frequency Tolerance (at 25°C)                                  | ±50ppm                       |
| Frequency Stability Over Operating Temperature Characteristics | ±100ppm                      |
| Operating Temperature Range                                    | -40°C ~ +85°C                |
| Storage Temperature Range                                      | -40°C ~ +85°C                |
| Shunt Capacitance (C <sub>0</sub> )                            | 7.0pF Max                    |
| Driver Level (Typical)   | 100μW                        |
| Load Capacitance(C <sub>L</sub> )                              | 16 pF                        |
| ESR  | 60 Ohm Max                   |
| Insulation Resistance  | More than 500Mohms at DC100V |
| Aging @25°C 1 <sup>st</sup> year (Max)                         | ±5ppm/year                   |

**REMARK:** SPECIFICATIONS SUBJECT TO CHANGE WITHOUT PRIOR NOTICE. PLEASE CONFIRM WITH OUR SALES ENGINEER.

## 2、DIMENSIONS (Unit: mm)

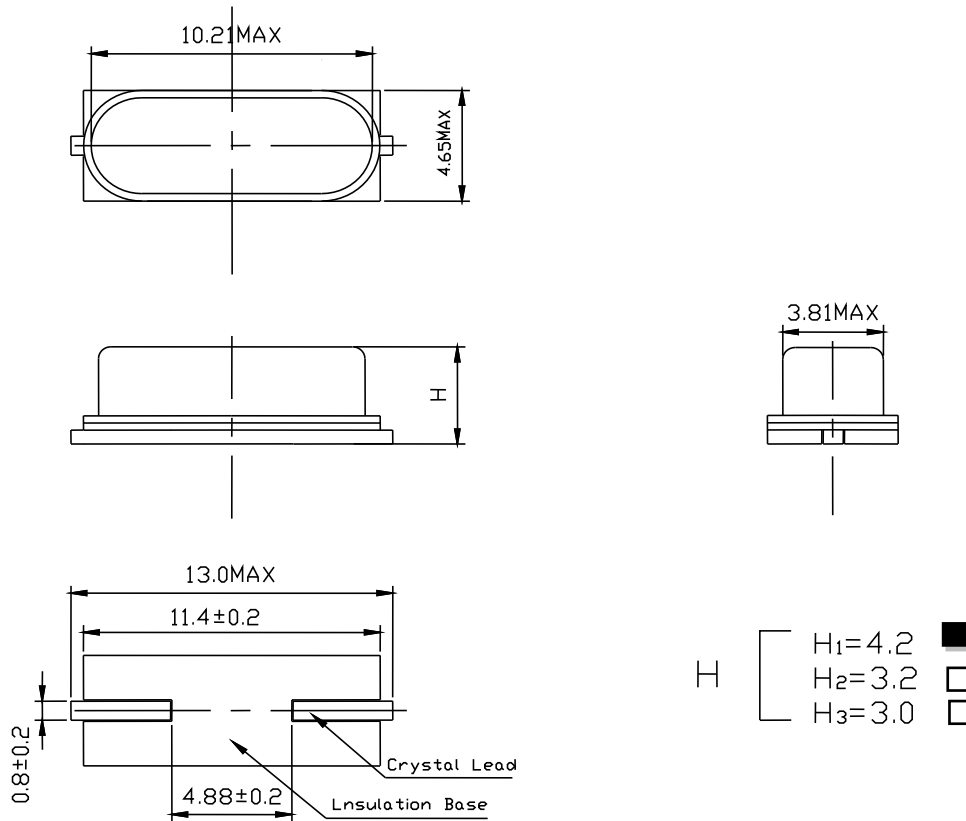

## 3、MARKING

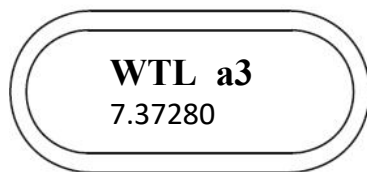

- WTL → Brand Logo
- 7.37280 → Frequency ( MHz )
- a → Week (a、b、c...z、A、B、C...Y、Z ,from 1 to 52week )
- 3 → YEAR (0=2020year, 1=2021year,2=2023year....)

### Marking Instruction :

The date code was marked on the crystal body, which will be easily traced back in case of quality issue.

#### 4、STRUCTURE ILLUSTRATION

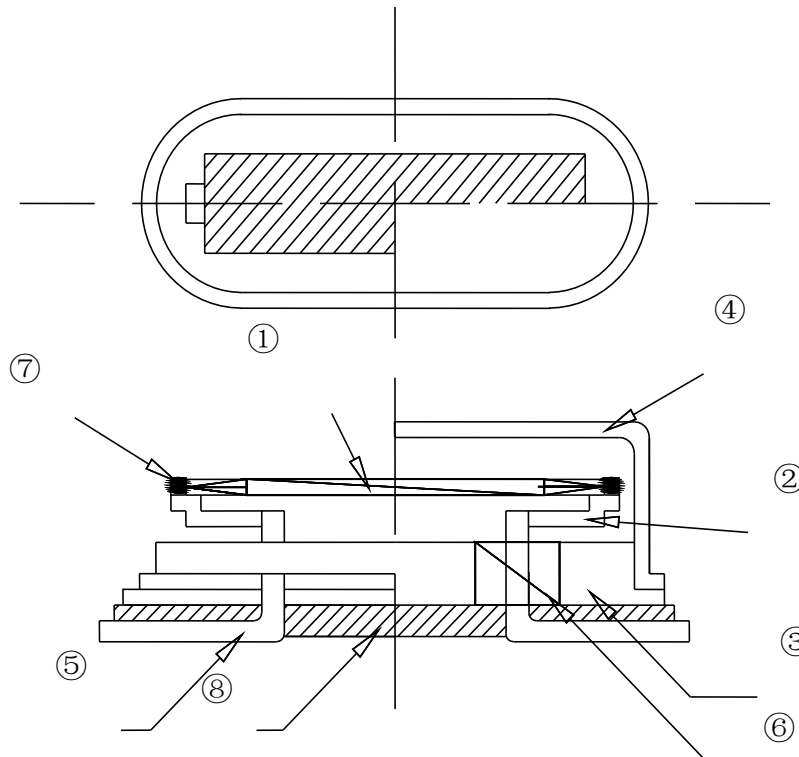

| NO | COMPONENT     | MATERIALS        | QTY | SURFACE                    |
|----|---------------|------------------|-----|----------------------------|
| ①  | CRYSTAL BLANK | SiO <sub>2</sub> | 1   | POLISH/ETCHED              |
| ②  | SUPPORTER     | COPPER           | 2   |                            |
| ③  | BASE          | Fe-NI            | 1   | NI PLATED                  |
| ④  | CAN           | NICKEL-COPPER    | 1   |                            |
| ⑤  | LEAD          | KOVAR            | 2   | NI PLATED+SOLDER<br>DIPPED |
| ⑥  | GLASS         | KOVER-GLASS      | 2   |                            |
| ⑦  | ADHESIVE GENT | Ag-URETHANE      | 2   |                            |
| ⑧  | INSULATOR     | PPS              | 1   |                            |

## 5、RELIABILITY SPECIFICATIONS

| Item                         | Conditions  | Result   |
|------------------------------|---|--|
| Low Temp. Storage            | Put the crystal into the $-40^{\circ}\text{C} \pm 2^{\circ}\text{C}$ constant temperature box for $500 \pm 2$ H , Measurement taken after 2 hour.   | $\Delta F \cong \pm 5$ PPM<br>$\Delta RR \cong \pm 15\%$ or<br>5 ohms                              |
| High Temp. Storage           | Put the crystal into the $+100^{\circ}\text{C} \pm 2^{\circ}\text{C}$ constant temperature box for $500 \pm 2$ H, Measurement taken after 2 hour.   | $\Delta F \cong \pm 5$ PPM<br>$\Delta RR \cong \pm 15\%$ or<br>5 ohms                              |
| High Temp & Humidity         | Put the crystal into the constant temperature & humid with the temperatures $85^{\circ}\text{C} \pm 3^{\circ}\text{C}$ and the humidity 98% for $500 \pm 2$ H. Measurement taken after 2 hour.  | $\Delta F \cong \pm 5$ PPM<br>$\Delta RR \cong \pm 15\%$ or<br>5 ohms                              |
| Thermal Shock                | Put the crystal into the constant temperature $-55^{\circ}\text{C} \pm 2^{\circ}\text{C}$ for $30 \pm 1$ M, then change the temperature to $+85^{\circ}\text{C} \pm 2^{\circ}\text{C}$ for $30 \pm 1$ M, the total is 100times. Measurement taken after 2 hour.   | $\Delta F \cong \pm 5$ PPM<br>$\Delta RR \cong \pm 15\%$ or<br>5 ohms                              |
| Resistance To Soldering Heat | Passed through the re-flow oven under the following condition. Preheat to $150^{\circ}\text{C} \pm 5^{\circ}\text{C}$ for 60 to 120 sec, and peak $265^{\circ}\text{C} \pm 5^{\circ}\text{C}$ for $10 \text{s} \pm 3 \text{sec}$ . Measurement taken after DUT being left at room temperature for at $24 \pm 2$ hours | $\Delta F \cong \pm 5$ PPM<br>$\Delta RR \cong \pm 15\%$ or<br>5 ohms                              |
| Drop Test                    | The crystal fall off the cement floor with the height $75 \text{cm} \pm 5 \text{cm}$ for 3 times . Measurement taken after 2 hour.  | $\Delta F \cong \pm 5$ PPM<br>$\Delta RR \cong \pm 15\%$ or<br>5 ohms                              |
| Vibration Test               | Apply 0.75mm vibration at sweep frequency $10 \sim 500$ Hz, for 2h. 10 cycles in each direction of 3 axis. Measurement taken after 2 hour.  | $\Delta F \cong \pm 5$ PPM<br>$\Delta RR \cong \pm 15\%$ or<br>5 ohms                              |
| Fine Leak                    | Take measurements with a helium leakage detector, or measure insulation resistance under pressure.  | $1 \times 10^{-2} \mu\text{Pa} \cdot \text{m}^3 / \text{s}$<br>Max or $IR \geq 500 \text{M}\Omega$ |
| Solder ability               | In $245 \pm 5^{\circ}\text{C}$ solder bath for $2 \pm 0.5$ seconds. 8-12X magnifier.  | Terminals shall be covered more then 95% with solder.  |

## 6、SUGGESTED REFLOW PROFILE

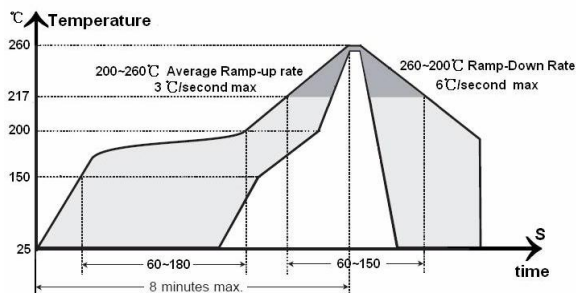

Peak temperature  $260^{\circ}\text{C} \pm 5^{\circ}\text{C}$  (10sec. max)

## 7、SUBSTANCES IN PRODUCT

| Drawing number | Disassembly Unit/component description | Homogeneous Material Name. | Substance Name | CAS No.    | Substance Mass. (mg) | Content Rate(%)per |
|----------------|--|----------------------------|----------------|------------|----------------------|--------------------|
| HC-49/SMD      | BASE                                   | Fe-NI                      | Fe             | 7439-89-6  | 290.9292             | 99.76%             |
|                |  |                            | C              | 7440-44-0  | 0.1458               | 0.05%              |
|                |  |                            | Mn             | 7439-96-5  | 0.4958               | 0.17%              |
|                |  |                            | P              | 7723-14-0  | 0.035                | 0.01%              |
|                |  |                            | Si             | 7440-21-3  | 0.0292               | 0.01%              |
|                | WIRE                                   | Kovar ring                 | Fe             | 7439-89-6  | 12.9626              | 37.38%             |
|                |  |                            | Cobal          | 7440-48-4  | 5.5091               | 15.89%             |
|                |  |                            | Nickel         | 7440-02-0  | 4.5369               | 13.08%             |
|                |  |                            | Copper         | 7440-50-8  | 10.3701              | 29.91%             |
|                |  |                            | Sn             | 7440-31-5  | 0.6481               | 1.87%              |
|                |  |                            | Ag             | 7440-22-4  | 0.6481               | 1.87%              |
|                | GLASS                                  | GLASS                      | SiO2           | 15468-32-3 | 27.083               | 70.00%             |
|                |  |                            | Al2O3          | 1344-28-1  | 3.4821               | 9.00%              |
|                |  |                            | B2O3           | 1303-86-2  | 3.0952               | 8.00%              |
|                |  |                            | Li2O           | 12057-24-8 | 0.4643               | 1.20%              |
|                |  |                            | Na2O           | 1313-59-3  | 3.869                | 10.00%             |
|                |  |                            | K2O            | 12136-45-7 | 0.5804               | 1.50%              |
|                | CAN                                    | Kovar                      | Copper         | 7440-50-8  | 97.8194              | 64.26%             |
|                |  |                            | Zn             | 7440-66-6  | 28.3137              | 18.60%             |
|                |  |                            | Nickel         | 7440-02-0  | 25.9543              | 17.05%             |
|                |  |                            | Fe             | 7439-89-6  | 0.137                | 0.09%              |
|                | Crystal Blank                          | Quartz                     | SiO2           | 14464-46-1 | 4.3658               | 100.00%            |
|                | Electrode                              | Ag                         | Ag             | 7440-22-4  | 0.3122               | 100.00%            |
|                | Sliver adhesive                        | Sliver adhesive            | Ag             | 7440-22-4  | 3                    | 75.00%             |
|                |  |                            | Xylene         | 1330-20-7  | 0.4                  | 10.00%             |
|                |  |                            | C6H12O3        | 111-15-9   | 0.152                | 3.80%              |
|                |  |                            | Isophorone     | 78-59-1    | 0.448                | 11.20%             |
|                | INSULATOR                              | INSULATOR                  | Poly           | 25212-74-2 | 10.40                | 40.00%             |
|                |  |                            | Glass Fiber    | 65997-17-3 | 10.40                | 40.00%             |
|                |  |                            | Filler         | 11097-59-9 | 4.42                 | 17.00%             |
|                |  |                            | Carbon Black   | 1333-86-4  | 0.78                 | 3.00%              |

All the products we provide meet the requirements of RoHS and Reach regulations, and we send SGS for ICP test every year.

8、PACKING SPECIFICATIONS (Unit: mm)

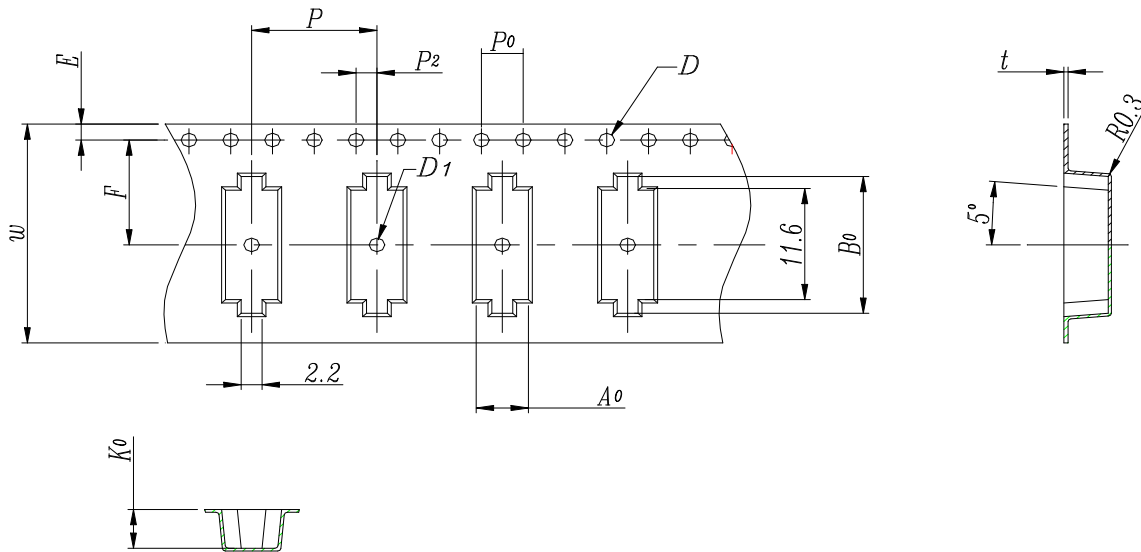

| Item | W      | A0      | B0       | K0       | E        | F        | P        | P0      | P2      | D    | D1   | t       |
|------|--------|---------|----------|----------|----------|----------|----------|---------|---------|------|------|---------|
| DIM  | 24±0.3 | 4.6±0.1 | 14.3±0.1 | 4.25±0.1 | 1.75±0.1 | 11.5±0.1 | 12.0±0.1 | 4.0±0.1 | 2.0±0.1 | ±1.5 | ±1.5 | 5.0±0.1 |

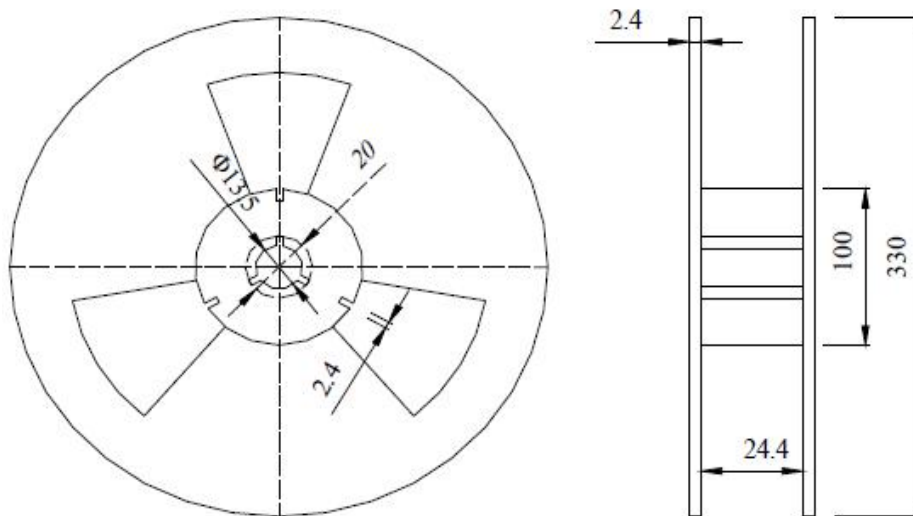

\*1000pcs/Reel



**9、WTL PART NUMBER SYSTEM :**

For example: WTL9M85577FO

[Instructions: for project management, WTL will trace back the part number to developer wherever it goes]

WTL - 9M - 855772 - FO

WTL: Brand

9M : Package Code

85577: Serial number , flow code , without any rules

FO: WTL Developer Code, for example: VH,CH,PZ,RZ,ML