

REVISION RECORD				
REV	ECN	DESCRIPTION	DRFT	DATE

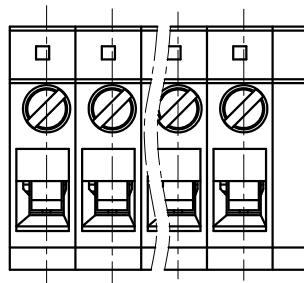

NOTES1:

UL Standard

- 1.Rated voltage/current : 300V / 20A
- 2.Torque value : M2.5 , 3.54Lb.in
- 3.Wire range : 30~12AWG

IEC Standard

- 1.Rated voltage/current : 250V / 24A
- 2.Torque value : M2.5 , 0.4N·m
- 3.Wire range : 0.5~2.5mm<sup>2</sup>

NOTES2:

- 1.Dimension shall be interpreted per ASME Y14.5-2009
- 2.Pitch : 5.0mm, Poles : N=01~24P
- 3.Stripping length : 12~13mm
- 4.Withstanding voltage : AC2000V/1Min
- 5.Operating temperature: -40°C~+105°C
- 6.Undimensioned tolerances:

Pitch range in mm		Nominal dimension range in mm				□	○	∠
To	Over	To	Over	To	Over	0.1/10		
6	10	10	24	30	60	60	100	150
±0.15	±0.20	±0.30	±0.30	±0.50	±0.70	±1.00	±1.30	±2'

7.RoHS Compliance

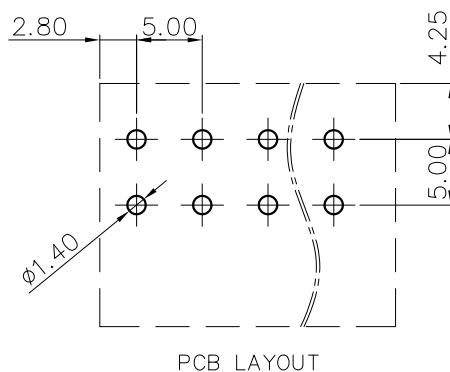
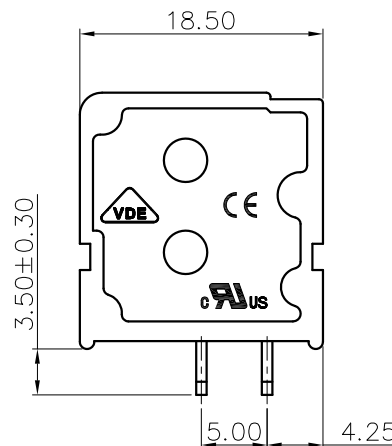
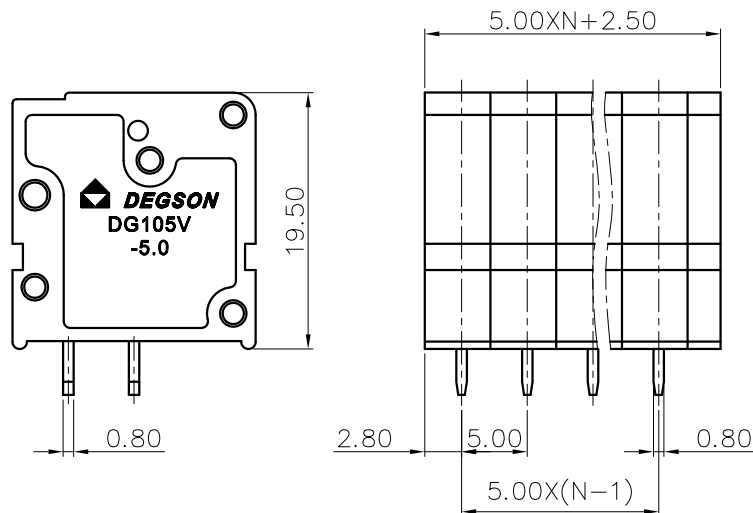

DG105V - 5.0 - XXP - 1Y - 00A (H)  
 (Series No.) (Pitch) (Poles) (Single Pitch) (Color):1.(Grey)2.(Blue)3.(Black)4.(Green)5.(Orange)6.(Red)7.(Transparent)8.(Yellow)9.(White)  
 (RoHS)  
 00A-(Standard)

DETACHED LISTS	PART NO.:	/			
	APPD:	/			
	CHKD:	/			
	DRFT:	/			
		 THIRD ANGLE PROJECTION		DRAWING NO.: / DO NOT SCALE DRAWING	
		NAME: NINGBO DEGSON ELECTRICAL CO., LTD DG105V-5.0-XXP-1Y-00A(H)		REV	DO
		TITLE: CUSTOMER DRAWING		SHEET	1/1
		SCALE		1:1	