

---

# conga-QMX6

Qseven® 2.1 Module with NXP® i.MX6 Processors

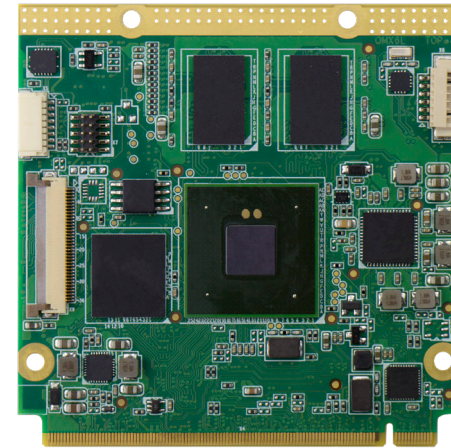

## *User's Guide*

Revision 1.6

# Revision History

Revision	Date (yyyy.mm.dd)	Author	Changes
0.1	2013.03.28	AEM	<ul style="list-style-type: none"><li>• Preliminary release</li></ul>
0.2	2013.11.05	AEM	<ul style="list-style-type: none"><li>• Corrected the LVDS data rates/resolutions supported in sections 2.1 "Feature List" and 5.8 "LVDS".</li><li>• Added information about the Atheros Quadcomm Ethernet PHY for conga-QMX6 revision B.0 in sections 2.1 "Feature List" and 5.3 "Gigabit Ethernet".</li><li>• Updated section 4 "Heatspreader". Added additional heatspreader variants.</li><li>• Updated section 5.2 "UART". Updated section 5.13 "Manufacturing/Jtag Interface".</li><li>• Added pin descriptions for the onboard UART connector and the RS-232 adapter cable in section 10.1 "UART/RS-232 Debug Port".</li><li>• Added section 10.3 "JTAG Interface".</li></ul>
0.3	2014.02.28	AEM	<ul style="list-style-type: none"><li>• Added the new Ethernet PHY (Qualcomm Atheros) for conga-QMX6 revision B.x to relevant sections.</li><li>• Changed the eMMC value of industrial variants from 2G to 4G.</li><li>• Deleted the row "RSVD" from table 23 "Manufacturing Signal Description".</li><li>• Edited section 5.2 "UART" and added caution statement.</li><li>• Corrected the pin number of signal DP_HDMI_HPD# in section 9.9 "DisplayPort".</li><li>• Updated the whole document.</li></ul>
1.0	2015.09.03	AEM	<ul style="list-style-type: none"><li>• Updated section 2.2 "Supported Operating Systems".</li><li>• Added note to table 7 "UART Signal Descriptions".</li><li>• Corrected the DP_HDMI_HPD# pin description in table 14 "DisplayPort".</li><li>• Corrected the LPC/GPIO6 (Pin 191) signal description in table 16 "LPC/GPIO".</li><li>• Changed Pin 56 from "RSVD" to "USB_VBUS_DRIVE" in various sections.</li><li>• Updated table 10 "USB 2.0 Signal Description" in compliance with the Qseven 2.0 Specification, Errata Document 1.0.</li><li>• Added table 28 "MIPI Signal Descriptions" and updated section 10.2 "MIPI/CMOS Camera".</li><li>• Updated document to revision B.x and C.x</li><li>• Official release</li></ul>
1.1	2016.05.04	AEM	<ul style="list-style-type: none"><li>• Updated the Options Information table in section 1 "Introduction". Also added Options Information table for revision C.x</li><li>• Updated section 2.3 "Mechanical Dimensions".</li><li>• Updated section 4 "Heatspreader".</li><li>• Replaced "Freescale" with "NXP" in the whole document.</li></ul>
1.2	2020.01.10	BEU	<ul style="list-style-type: none"><li>• Updated table references throughout the document</li><li>• Updated information about handling electrostatic sensitive devices in preface section</li><li>• Added new variant "PN:016318" to table 4</li><li>• Updated section 4 "Heatspreader"</li><li>• Updated reference to power supply design guide in section 5.14 "Power Control"</li><li>• Added note about min. pulse width to several button signals in table 23 and 24</li><li>• Added note about WDOOUT signal below table 25</li><li>• Updated section 11 "Industry Specifications"</li><li>• Added information and note to section 10.7 "eMMC"</li></ul>

1.3	2022.10.25	BEU	<ul style="list-style-type: none"> <li>• Updated document to revision D.x</li> <li>• Updated congatec AG to congatec GmbH throughout the document</li> <li>• Added software license information to preface section</li> <li>• Restructured preface section</li> <li>• Updated section 1 "Introduction"</li> <li>• Updated table 7 "Feature Summary"</li> <li>• Added module variant 016318 to table 8 "Cooling Solution Variants"</li> <li>• Updated supported operating systems in section 2.2 "Supported Operating Systems"</li> <li>• Added module variants to section 2.5 "Power Consumption"</li> <li>• Updated storage temperature for commercial variants in section 2.7 "Environmental Specifications"</li> <li>• Updated block diagram in section 3 "Block Diagram"</li> <li>• Added note about revision D.x onboard PCIe clock generator in section 5.1 "PCI Express™"</li> <li>• Added revision D.x transceiver in section 5.3 "Gigabit Ethernet"</li> <li>• Added UART0_RTS# and UART0_CTS# assembly options to table 10 "Edge Finger Pinout"</li> <li>• Added revision D.x UART0_CTS# and UART0_RTS# information to note below table 12 "UART Signal Descriptions"</li> <li>• Updated USB_ID and USB_OTG_PEN signals descriptions in table 15</li> <li>• Added revision D.x information to section 10.2 "MIPI/CMOS Camera"</li> <li>• Renamed section 10.6 "DDR3 Memory" to "DD3RL Memory" and updated it</li> <li>• Added revision D.x support for 1.8V micro SD cards to section 10.2 "Micro SD"</li> <li>• Removed section 11 "Industry Specifications"</li> </ul>
1.4	2023.12.23	BEU	<ul style="list-style-type: none"> <li>• Updated title page</li> <li>• Updated RoHS Directive in preface section</li> <li>• Removed revision D.x throughout the document</li> <li>• Added E.x to note in section 1 "Introduction"</li> <li>• Removed Gen 2 from PCIe in section 2.1 "Feature List" and 3 "Block Diagram"</li> <li>• Added note regarding long-term storage to section 2.7 "Environmental Specifications"</li> <li>• Added note regarding long-term storage to section 4 "Heatspreader"</li> <li>• Updated section 5.1 "PCI Express"</li> <li>• Added revision E.x to section 5.3 "Gigabit Ethernet"</li> <li>• Added comment for PCIe Clock signals to table 11</li> <li>• Added revision E.x to note under table 12 "UART Signal Descriptions"</li> <li>• Added revision E.x to section 10.2 "MIPI/CMOS Camera"</li> <li>• Added revision E.x to section 10.7 "eMMC"</li> <li>• Added revision E.x to section 10.8 "Micro SD"</li> </ul>
1.5	2025.01.31	RVI	<ul style="list-style-type: none"> <li>• Updated the preface section</li> <li>• Added WEEE Compliance Declaration</li> <li>• Added a note to section 2.3 "Mechanical Dimensions"</li> <li>• Updated section 2.7 "Environmental Specifications"</li> <li>• Added a new section 2.8 "Storage Specifications"</li> </ul>
1.6	2026.03.09	HSU	<ul style="list-style-type: none"> <li>• Updated additional reference sources in the Preface section</li> <li>• Updated links for application notes and PDFs to point to the conga-wiki pages</li> </ul>

---

# Preface

---

This user's guide provides information about the components, features, connectors and signals available on the conga-QMX6 Revision E.x. It is one of four documents that you should refer to when designing an NXP® i.MX6 based Qseven® application. The other reference documents that should be used include the following:

Qseven® Design Guide

Qseven® Specification

NXP® i.MX6 Applications Processor Reference Manual (available at [www.nxp.com](http://www.nxp.com))

The links to these documents can be found on the congatec GmbH website at [www.congatec.com](http://www.congatec.com).

Ensure regular consultation of the customer login area at [www.congatec.com](http://www.congatec.com) and the congatec customer knowledge base at [wiki.congatec.com](http://wiki.congatec.com) for the most recent and legally binding product-related documents—such as errata sheets, known issues, and Product Change Notifications (PCNs).

Additionally, refer to the official websites of the respective silicon vendors for further information, including general chip limitations, errata sheets, sighting reports, and other technical or regulatory updates. These documents may contain mandatory and legally relevant information concerning product usage, compliance, and performance.

## Software Licenses

### Notice Regarding Open Source Software

The congatec products contain Open Source software that has been released by programmers under specific licensing requirements such as the “General Public License” (GPL) Version 2 or 3, the “Lesser General Public License” (LGPL), the “ApacheLicense” or similar licenses.

You can find the specific details at <https://www.congatec.com/en/licenses/>.

Enter the following command “license” in the bootloader to get the complete product related license information.

To the extent that any accompanying material such as instruction manuals, handbooks etc. contain copyright notices, conditions of use or licensing requirements that contradict any applicable Open Source license, these conditions are inapplicable. The use and distribution of any Open Source software contained in the product is exclusively governed by the respective Open Source license.

The Open Source software is provided by its programmers without ANY WARRANTY, whether implied or expressed, of any fitness for a particular purpose, and the programmers DECLINE ALL LIABILITY for damages, direct or indirect, that result from the use of this software.

congatec's liability with regards to the open source Software is as set out in congatec's Software License Information.

---

## Disclaimer

The information contained within this user's guide, including but not limited to any product specification, is subject to change without notice.

congatec GmbH provides no warranty with regard to this user's guide or any other information contained herein and hereby expressly disclaims any implied warranties of merchantability or fitness for any particular purpose with regard to any of the foregoing. congatec GmbH assumes no liability for any damages incurred directly or indirectly from any technical or typographical errors or omissions contained herein or for discrepancies between the product and the user's guide. In no event shall congatec GmbH be liable for any incidental, consequential, special, or exemplary damages, whether based on tort, contract or otherwise, arising out of or in connection with this user's guide or any other information contained herein or the use thereof.

## Intended Audience

This user's guide is intended for technically qualified personnel. It is not intended for general audiences.

## RoHS Directive

All congatec GmbH designs comply with EU RoHS Directive 2011/65/EU and Delegated Directive 2015/863.

## WEEE Directive



To comply with Directive 2012/19/EU on Waste Electrical and Electronic Equipment (WEEE), ensure that this product is disposed of correctly at the end of its lifecycle. Customers are required to take electrical and electronic equipment to designated collection facilities separate from unsorted municipal waste, following applicable regional laws.

Proper disposal through designated collection points allows for the recycling, recovery, and reuse of valuable materials, supporting a more efficient use of resources and reducing environmental impact.



**Note**  
*Standalone congatec components, such as modules, carrier boards, and cooling solutions are designed to function only within other products. WEEE registration for the complete product must be completed by the entity placing the final product on the market.*

---

## Electrostatic Sensitive Device



All congatec GmbH products are electrostatic sensitive devices. They are enclosed in static shielding bags, and shipped enclosed in secondary packaging (protective packaging). The secondary packaging does not provide electrostatic protection.

Do not remove the device from the static shielding bag or handle it, except at an electrostatic-free workstation. Also, do not ship or store electronic devices near strong electrostatic, electromagnetic, magnetic, or radioactive fields unless the device is contained within its original packaging. Be aware that failure to comply with these guidelines will void the congatec GmbH Limited Warranty.

## Symbols

The following symbols are used in this user's guide:



### Warning

*Warnings indicate conditions that, if not observed, can cause personal injury.*



### Caution

*Cautions warn the user about how to prevent damage to hardware or loss of data.*



### Note

*Notes call attention to important information that should be observed.*

## Copyright Notice

Copyright © 2013, congatec GmbH. All rights reserved. All text, pictures and graphics are protected by copyrights. No copying is permitted without written permission from congatec GmbH.

congatec GmbH has made every attempt to ensure that the information in this document is accurate yet the information contained within is supplied "as-is".

---

## Trademarks

Product names, logos, brands, and other trademarks featured or referred to within this user's guide, or the congatec website, are the property of their respective trademark holders. These trademark holders are not affiliated with congatec GmbH, our products, or our website.

## Warranty

congatec GmbH makes no representation, warranty or guaranty, express or implied regarding the products except its standard form of limited warranty ("Limited Warranty") per the terms and conditions of the congatec entity, which the product is delivered from. These terms and conditions can be downloaded from [www.congatec.com](http://www.congatec.com). congatec GmbH may in its sole discretion modify its Limited Warranty at any time and from time to time.

The products may include software. Use of the software is subject to the terms and conditions set out in the respective owner's license agreements, which are available at [www.congatec.com](http://www.congatec.com) and/or upon request.

Beginning on the date of shipment to its direct customer and continuing for the published warranty period, congatec GmbH represents that the products are new and warrants that each product failing to function properly under normal use, due to a defect in materials or workmanship or due to non conformance to the agreed upon specifications, will be repaired or exchanged, at congatec's option and expense.

Customer will obtain a Return Material Authorization ("RMA") number from congatec GmbH prior to returning the non conforming product freight prepaid. congatec GmbH will pay for transporting the repaired or exchanged product to the customer.

Repaired, replaced or exchanged product will be warranted for the repair warranty period in effect as of the date the repaired, exchanged or replaced product is shipped by congatec, or the remainder of the original warranty, whichever is longer. This Limited Warranty extends to congatec's direct customer only and is not assignable or transferable.

Except as set forth in writing in the Limited Warranty, congatec makes no performance representations, warranties, or guarantees, either express or implied, oral or written, with respect to the products, including without limitation any implied warranty (a) of merchantability, (b) of fitness for a particular purpose, or (c) arising from course of performance, course of dealing, or usage of trade.

congatec GmbH shall in no event be liable to the end user for collateral or consequential damages of any kind. congatec shall not otherwise be liable for loss, damage or expense directly or indirectly arising from the use of the product or from any other cause. The sole and exclusive remedy against congatec, whether a claim sound in contract, warranty, tort or any other legal theory, shall be repair or replacement of the product only.

---

## Certification

congatec GmbH is certified to DIN EN ISO 9001 standard.



## Technical Support

congatec GmbH technicians and engineers are committed to providing the best possible technical support for our customers so that our products can be easily used and implemented. We request that you first visit our website at [www.congatec.com](http://www.congatec.com) for the latest documentation, utilities and drivers, which have been made available to assist you. If you still require assistance after visiting our website then contact our technical support department by email at [support@congatec.com](mailto:support@congatec.com).

## Terminology

Term	Description
PCI Express (PCIe)	Peripheral Component Interface Express – next-generation high speed Serialized I/O bus
ARM	Advanced RISC Machine
JTAG	Joint Test Action Group
eCSPI	Enhanced Configurable Serial Peripheral Interface
MIPI	Mobile Industry CPU Interface
GPIO	General Purpose Input Output
RGMII	Reduced Gigabit Media Independent Interface
PCI Express Lane	One PCI Express Lane is a set of 4 signals that contains two differential lines for transmitting and two differential lines for Receiving. Clocking information is embedded into the data stream.
PCI Express Mini Card	PCI Express Mini Card add-in card is a small size unique form factor optimized for mobile computing platforms.
eMMC	Embedded Multi Media Card is a non-volatile memory system, which frees the processor from low level flash memory management.
SDIO card	SDIO (Secure Digital Input Output) is a non-volatile memory card format developed for use in portable devices.
USB	Universal Serial Bus
SATA	Serial AT Attachment: serial-interface standard for hard disks
HDA	High Definition Audio
HDMI	High Definition Multimedia Interface. HDMI supports standard, enhanced, or high-definition video, plus multi-channel digital audio on a single cable.
TMDS	Transition Minimized Differential Signaling. TMDS is a signaling interface defined by Silicon Image that is used for DVI and HDMI.
DVI	Digital Visual Interface is a video interface standard developed by the Digital Display Working Group (DDWG).
I <sup>2</sup> C Bus	Inter-Integrated Circuit Bus: is a simple two-wire bus with a software-defined protocol that was developed to provide the communications link between integrated circuits in a system.
SM Bus	System Management Bus: is a popular derivative of the I <sup>2</sup> C-bus.
SPI Bus	Serial Peripheral Interface is a synchronous serial data link standard named by Motorola that operates in full duplex mode.
CAN Bus	Controller-area network is a vehicle bus standard designed to allow microcontrollers and devices to communicate with each other within a vehicle without a host computer.
AMBA	Advanced Microcontroller Bus Architecture
IOMUX	Input Output Multiplexer
GbE	Gigabit Ethernet
LVDS	Low-Voltage Differential Signaling
DDC	Display Data Channel is an I <sup>2</sup> C bus interface between a display and a graphics adapter.
N.C.	Not connected
N.A.	Not available
T.B.D.	To be determined

# Contents

1	INTRODUCTION.....	13	4.1	Heatspreader Dimensions.....	29
2	Specifications.....	17	5	Connector Subsystems.....	31
2.1	Feature List.....	17	5.1	PCI Express.....	32
2.2	Supported Operating Systems.....	18	5.2	UART/RS-232.....	32
2.3	Mechanical Dimensions.....	18	5.3	Gigabit Ethernet.....	33
2.4	Supply Voltage Standard Power.....	19	5.4	SATA.....	33
2.4.1	Electrical Characteristics.....	19	5.5	USB 2.0.....	34
2.4.2	Rise Time.....	19	5.6	SD/SDIO/MMC.....	34
2.5	Power Consumption.....	20	5.7	HDA/I2S/AC'97.....	34
2.5.1	NXP® i.MX6 Cortex A9 1.0 GHz Single Core 512kB L2 cache	21	5.8	LVDS.....	35
2.5.2	NXP® i.MX6 Cortex A9 1.0 GHz Dual Lite 512kB L2 cache.....	21	5.9	HDMI®.....	35
2.5.3	NXP® i.MX6 Cortex A9 1.0 GHz Dual Core 1MB L2 cache.....	21	5.10	LPC/GPIO.....	36
2.5.4	NXP® i.MX6 Cortex A9 1.0 GHz Quad Core 1MB L2 cache.....	22	5.11	SPI.....	36
2.5.5	NXP® i.MX6 Cortex A9 1.0 GHz Quad Core 1MB L2 cache.....	22	5.12	CAN Bus.....	36
2.5.6	NXP® i.MX6 Cortex A9 800 MHz Single Core 512kB L2 cache (2GB eMMC).....	22	5.13	Manufacturing/JTAG Interface.....	36
2.5.7	NXP® i.MX6 Cortex A9 800 MHz Dual Lite 512kB L2 cache (2GB eMMC).....	23	5.14	Power Control.....	37
2.5.8	NXP® i.MX6 Cortex A9 800 MHz Dual Core 1MB L2 cache (2GB eMMC).....	23	5.15	Power Management.....	38
2.5.9	NXP® i.MX6 Cortex A9 800 MHz Quad Core 1MB L2 cache (2GB eMMC).....	23	5.16	Watchdog.....	39
2.5.10	NXP® i.MX6 Cortex A9 800 MHz Quad Core 1MB L2 cache (4GB eMMC).....	24	5.17	I2C Bus.....	39
2.6	Supply Voltage Battery Power.....	24	6	Additional Features.....	40
2.6.1	CMOS Battery Power Consumption.....	24	6.1	High Assurance Boot (HAB).....	40
2.7	Environmental Specifications.....	24	6.2	Dedicated Hardware Accelerators.....	40
2.8	Storage Specifications.....	25	6.3	Power Management.....	40
2.8.1	Module.....	25	6.4	Dynamic Voltage and Frequency Scaling.....	40
2.8.2	Cooling Solution.....	26	6.5	Smart Speed Technology.....	41
3	Block Diagram.....	27	6.6	Suspend Mode.....	41
4	Heatspreader.....	28	7	ARM Technologies.....	42
			7.1	Media Processing Engine (MPE-NEON).....	42
			7.2	Jazelle DBX.....	42
			7.3	TrustZone.....	42
			7.4	Floating Point Unit.....	42
			8	conga Tech Notes.....	43

---

8.1	NXP® i.MX6 Processor Features.....	43
8.1.1	Temperature Monitor (TEMPMON).....	43
8.2	Thermal Management .....	43
8.3	Audio Mux .....	44
8.4	LVDS Bridge .....	44
8.5	USB Port Connections.....	44
9	Interface - Signal Descriptions and Pinout Tables.....	46
9.1	Bootstrap Signals .....	62
10	Onboard Interfaces and Devices .....	63
10.1	UART/RS-232 Debug Port.....	63
10.2	MIPI/CMOS Camera .....	64
10.3	JTAG Interface .....	66
10.4	SPI Flash.....	66
10.5	Android Buttons.....	67
10.6	DDR3L Memory .....	67
10.7	eMMC .....	67
10.8	Micro SD .....	67

# List of Tables

---

Table 1	Commercial variants .....	14
Table 2	Industrial Variants.....	14
Table 3	Commercial Variants .....	15
Table 4	Industrial Variants.....	15
Table 5	Commercial Variants .....	16
Table 6	Industrial Variants.....	16
Table 7	Feature Summary.....	17
Table 8	Cooling Solution Variants.....	28
Table 9	Signal Tables Terminology Descriptions .....	46
Table 10	Edge Finger Pinout.....	47
Table 11	PCI Express Signal Descriptions .....	50
Table 12	UART Signal Descriptions .....	50
Table 13	Ethernet Signal Descriptions.....	51
Table 14	SATA Signal Descriptions.....	52
Table 15	USB 2.0 Signal Descriptions.....	52
Table 16	SDIO/MMC Signal Descriptions .....	53
Table 17	HDA/I2S/SPDIF Signal Descriptions .....	54
Table 18	LVDS Signal Descriptions.....	54
Table 19	DisplayPort Signal Descriptions.....	56
Table 20	HDMI® Signal Descriptions .....	56
Table 21	LPC/GPIO Signal Descriptions.....	57
Table 22	SPI Interface Signal Descriptions .....	57
Table 23	CAN Bus Signal Descriptions.....	58
Table 24	Input Power Signal Descriptions.....	58
Table 25	Power Control Signal Descriptions .....	58
Table 26	Power Management Signal Descriptions.....	59
Table 27	Miscellaneous Signal Descriptions.....	59
Table 28	Manufacturing/JTAG Signal Descriptions.....	60
Table 29	Thermal Management Signal Descriptions.....	61
Table 30	Fan Control Signal Descriptions .....	61
Table 31	Bootstrap Signal Descriptions.....	62
Table 32	UART Signal Descriptions .....	63
Table 33	MIPI Signal Descriptions .....	64
Table 34	JTAG Interface Signal Descriptions .....	66
Table 35	Android Button Signal Descriptions.....	67

# 1 INTRODUCTION

---

## Qseven® Concept

The Qseven® concept is an off-the-shelf, multi vendor, Computer-On-Module that integrates all the core components of a common PC and is mounted onto an application specific carrier board. Qseven® modules have a standardized form factor of 70mm x 70mm and a specified pinout based on the high speed MXM system connector. The pinout remains the same regardless of the vendor. The Qseven® module provides the functional requirements for an embedded application. These functions include, but are not limited to, graphics, sound, mass storage, network interface and multiple USB ports.

A single ruggedized MXM connector provides the carrier board interface to carry all the I/O signals to and from the Qseven® module. This MXM connector is a well known and proven high speed signal interface connector that is commonly used for high speed PCI Express® graphics cards in notebooks.

Carrier board designers can use as little or as many of the I/O interfaces as deemed necessary. The carrier board can therefore provide all the interface connectors required to attach the system to the application specific peripherals. This versatility allows the designer to create a dense and optimized package, which results in a more reliable product while simplifying system integration.

The conga-QEVAL/Qseven® 2.0 evaluation carrier board provides carrier board designers with a reference design platform and the opportunity to test all the Qseven® I/O interfaces available and then choose what are suitable for their application. Qseven® applications are scalable, which means once a carrier board has been created there is the ability to diversify the product range through the use of different performance class Qseven® modules. Simply unplug one module and replace it with another, no need to redesign the carrier board.



### Note

*The conga-QMX6 B.x and later revisions are designed based on the Qseven Specification 2.0. Revision C.x follows the Qseven Specification 2.0 Errata. Revision E.x follows the Qseven Specification 2.1.*

## conga-QMX6 Options Information (Revision B.x)

The conga-QMX6 revision B.x was available in eleven variants (seven commercial and four industrial). Below you will find an order table showing the base configuration modules that were offered by congatec GmbH. The part numbers are obsolete as of revision C.x. For more information about additional conga-QMX6 variants offered by congatec, contact your local congatec sales representative or visit the congatec website at [www.congatec.com](http://www.congatec.com).

Table 1 Commercial variants

Part-No.	016100	016101	016102	016103	016104	016105	016106
Processor	NXP® i.MX6 Cortex A9 1.0 GHz Single Core	NXP® i.MX6 Cortex A9 1.0 GHz Dual Lite	NXP® i.MX6 Cortex A9 1.0 GHz Dual Core	NXP® i.MX6 Cortex A9 1.0 GHz Quad Core	NXP® i.MX6 Cortex A9 1.0 GHz Quad Core	NXP® i.MX6 Cortex A9 1.0 GHz Quad Core	NXP® i.MX6 Cortex A9 1.0 GHz Quad Core
L2 Cache	512 kB	512 kB	1 MB	1 MB	1 MB	1 MB	1 MB
Onboard Memory	1GB DDR3L	1GB DDR3L	1GB DDR3L	1GB DDR3L	2GB DDR3L	2GB DDR3L	1GB DDR3L
eMMC up to 8GB	4GB	4GB	4GB	4GB	4GB	8GB	8GB
PCI Express Lane	Yes	Yes	Yes	Yes	Yes	Yes	Yes
CAN Bus	Yes	Yes	Yes	Yes	Yes	Yes	Yes
Gigabit Ethernet	Yes	Yes	Yes	Yes	Yes	Yes	Yes
SATA	No	No	Yes	Yes	Yes	Yes	Yes

Table 2 Industrial Variants

Part-No.	016110	016111	016112	016113
Processor	NXP® i.MX6 Cortex A9 800 MHz Single Core	NXP® i.MX6 Cortex A9 800 MHz Dual Lite	NXP® i.MX6 Cortex A9 800 MHz Dual Core	NXP® i.MX6 Cortex A9 800 MHz Quad Core
L2 Cache	512 kB	512 kB	1 MB	1 MB
Onboard Memory	1GB DDR3L	1GB DDR3L	1GB DDR3L	1GB DDR3L
eMMC up to 8GB	4GB	4GB	4GB	4GB
PCI Express Lane	Yes	Yes	Yes	Yes
CAN Bus	Yes	Yes	Yes	Yes
Gigabit Ethernet	Yes	Yes	Yes	Yes
SATA	No	No	Yes	Yes



### Caution

*Do not alter the conga-QMX6 boot fuse settings. These fuse settings are already programmed during production process and are not protected against alteration. Changing the boot fuse settings will void the congatec GmbH warranty.*

## conga-QMX6 Options Information (Revision C.x)

Revision C.x of the conga-QMX6 was available in twelve variants (seven commercial and five industrial). Below you will find an order table showing the base configuration modules that were offered by congatec GmbH. For more information about additional conga-QMX6 variants offered by congatec, contact your local congatec sales representative or visit the congatec website at [www.congatec.com](http://www.congatec.com).

Table 3 Commercial Variants

Part-No.	016300	016301	016302	016303	016304	016305	016306
Processor	NXP® i.MX6 Cortex A9 1.0 GHz Single Core	NXP® i.MX6 Cortex A9 1.0 GHz Dual Lite	NXP® i.MX6 Cortex A9 1.0 GHz Dual Core	NXP® i.MX6 Cortex A9 1.0 GHz Quad Core	NXP® i.MX6 Cortex A9 1.0 GHz Quad Core	NXP® i.MX6 Cortex A9 1.0 GHz Quad Core	NXP® i.MX6 Cortex A9 1.0 GHz Quad Core
L2 Cache	512 kB	512 kB	1 MB	1 MB	1 MB	1 MB	1 MB
Onboard Memory	1GB DDR3L	1GB DDR3L	1GB DDR3L	1GB DDR3L	2GB DDR3L	2GB DDR3L	1GB DDR3L
eMMC up to 8GB	4GB	4GB	4GB	4GB	4GB	8GB	8GB
PCI Express Lane	Yes	Yes	Yes	Yes	Yes	Yes	Yes
CAN Bus	Yes	Yes	Yes	Yes	Yes	Yes	Yes
Gigabit Ethernet	Yes	Yes	Yes	Yes	Yes	Yes	Yes
SATA	No	No	Yes	Yes	Yes	Yes	Yes

Table 4 Industrial Variants

Part-No.	016310	016311	016312	016313	016318
Processor	NXP® i.MX6 Cortex A9 800 MHz Single Core	NXP® i.MX6 Cortex A9 800 MHz Dual Lite	NXP® i.MX6 Cortex A9 800 MHz Dual Core	NXP® i.MX6 Cortex A9 800 MHz Quad Core	NXP® i.MX6 Cortex A9 800 MHz Quad Core
L2 Cache	512 kB	512 kB	1 MB	1 MB	1 MB
Onboard Memory	1GB DDR3L	1GB DDR3L	1GB DDR3L	1GB DDR3L	4GB DDR3L
eMMC up to 8GB	4GB	4GB	4GB	4GB	4GB
PCI Express Lane	Yes	Yes	Yes	Yes	Yes
CAN Bus	Yes	Yes	Yes	Yes	Yes
Gigabit Ethernet	Yes	Yes	Yes	Yes	Yes
SATA	No	No	Yes	Yes	Yes



### Caution

*Do not alter the conga-QMX6 boot fuse settings. These fuse settings are already programmed during production process and are not protected against alteration. Changing the boot fuse settings will void the congatec GmbH warranty.*

## conga-QMX6 Options Information (Revision E.x)

Revision E.x of the conga-QMX6 is currently available in ten variants (five commercial and five industrial). Below you will find an order table showing the base configuration modules that are currently offered by congatec GmbH. For more information about additional conga-QMX6 variants offered by congatec, contact your local congatec sales representative or visit the congatec website at [www.congatec.com](http://www.congatec.com).

Table 5 Commercial Variants

Part-No.	016300	016301	016302	016303	016304
Processor	NXP® i.MX6 Cortex A9 1.0 GHz Single Core	NXP® i.MX6 Cortex A9 1.0 GHz Dual Lite	NXP® i.MX6 Cortex A9 1.0 GHz Dual Core	NXP® i.MX6 Cortex A9 1.0 GHz Quad Core	NXP® i.MX6 Cortex A9 1.0 GHz Quad Core
L2 Cache	512 kB	512 kB	1 MB	1 MB	1 MB
Onboard Memory	1GB DDR3L	1GB DDR3L	1GB DDR3L	1GB DDR3L	2GB DDR3L
eMMC	32GB	32GB	32GB	32GB	32GB
PCI Express Lane	Yes	Yes	Yes	Yes	Yes
CAN Bus	Yes	Yes	Yes	Yes	Yes
Gigabit Ethernet	Yes	Yes	Yes	Yes	Yes
SATA	No	No	Yes	Yes	Yes

Table 6 Industrial Variants

Part-No.	016310	016311	016312	016313	016318
Processor	NXP® i.MX6 Cortex A9 800 MHz Single Core	NXP® i.MX6 Cortex A9 800 MHz Dual Lite	NXP® i.MX6 Cortex A9 800 MHz Dual Core	NXP® i.MX6 Cortex A9 800 MHz Quad Core	NXP® i.MX6 Cortex A9 800 MHz Quad Core
L2 Cache	512 kB	512 kB	1 MB	1 MB	1 MB
Onboard Memory	1GB DDR3L	1GB DDR3L	1GB DDR3L	1GB DDR3L	4GB DDR3L
eMMC	32GB	32GB	32GB	32GB	32GB
PCI Express Lane	Yes	Yes	Yes	Yes	Yes
CAN Bus	Yes	Yes	Yes	Yes	Yes
Gigabit Ethernet	Yes	Yes	Yes	Yes	Yes
SATA	No	No	Yes	Yes	Yes



### Caution

*Do not alter the conga-QMX6 boot fuse settings. These fuse settings are already programmed during production process and are not protected against alteration. Changing the boot fuse settings will void the congatec GmbH warranty.*

## 2 Specifications

### 2.1 Feature List

Table 7 Feature Summary

Form Factor	Qseven   70x70mm
Processor	NXP® i.MX6 Cortex A9
DRAM	Up to 4 GByte onboard DDR3L memory   1066 MT/s
Ethernet	1x Gbit Ethernet
I/O Interfaces	5x USB 2.0 (shared with 1x USB OTG client)   SATA (only i.MX6 Dual/Quad)   1x SDIO   1x PCIe   I <sup>2</sup> C Bus   CAN Bus   SPI
Mass Storage	eMMC up to 32 GByte   Onboard MicroSD socket
Sound	1x I <sup>2</sup> S
Graphics	Integrated in NXP i.MX6   Video (VPU)   2D Graphics (GPU2D) and 3D Graphics (GPU3D)   3D graphics with 4 shaders up to 200MT/s dual stream 1080p/720p decoder/encoder   OpenGL   OpenCL   OpenVG 1.1
Video Interfaces	HDMI v1.4 support supported by Qseven specification. 2x LVDS (2x 24 bit)   1x LVDS (1x 24 bit) up to WUXGA resolution   1920x1200 pixel and HD1080   Supports 18bit and 24bit dual channel up to WUXGA 1920x1200
Features	Watchdog Timer   JTAG debug interface   MIPI CSI-2 camera interface on flat foil connector   High Precision Real Time Clock
Security	High Assurance Boot support   TrustZone®   RNG
Boot Loader	U-Boot boot loader
Operating Systems	Linux   Android
Power Consumption	Typical application 3-5W @ 5V
Temperature Range	Operating Temperature Range: 0 to +60°C commercial grade -40 to +85°C industrial grade Storage Temperature Range: -40 to +85°C
Humidity	Operating: 10 - 90% r. H. non cond. Storage: 5 - 95% r. H. non cond.



#### Note

Some of the features mentioned in the above feature summary are optional. Check the article number of your module and compare it to the conga-QMX6 options information list on page 12 of this user's guide to determine what options are available on your particular module.

## 2.2 Supported Operating Systems

The conga-QMX6 supports the following operating systems.

- Android
- Linux

## 2.3 Mechanical Dimensions

- 70.0 mm x 70.0 mm @ (2 ¾" x 2 ¾")
- The Qseven™ module, including the heatspreader plate, PCB thickness and bottom components, is up to approximately 12mm thick.

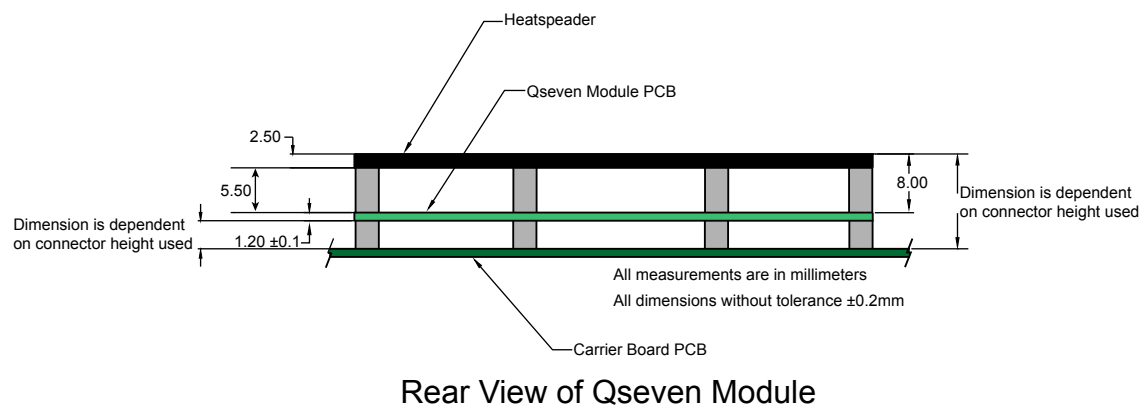

### Note

3D models of congatec products are available at [www.congatec.com/login](http://www.congatec.com/login). These models indicate the overall length, height and width of each product. If you need login access, contact your local sales representative.

## 2.4 Supply Voltage Standard Power

- 5V DC  $\pm$  5%

The dynamic range shall not exceed the static range.

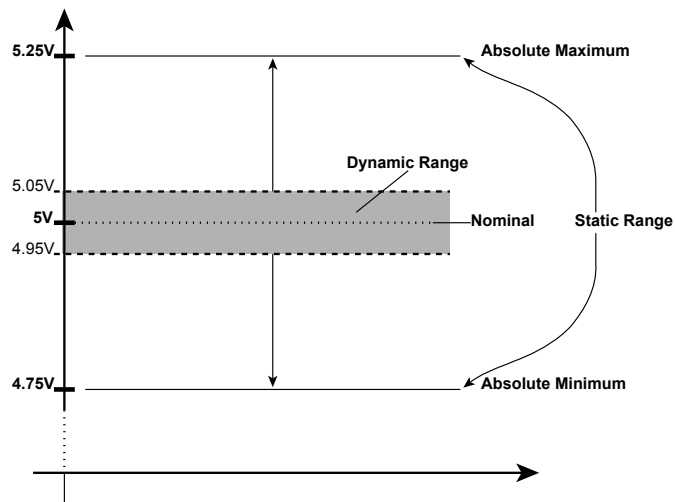

### 2.4.1 Electrical Characteristics

Characteristics			Min.	Typ.	Max.	Units	Comment
5V	Voltage	$\pm$ 5%	4.75	5.00	5.25	Vdc	
	Ripple		-	-	$\pm$ 50	mV <sub>pp</sub>	0-20MHz
	Current						
5V_SB	Voltage	$\pm$ 5%	4.75	5.00	5.25	Vdc	
	Ripple				$\pm$ 50	mV <sub>pp</sub>	

### 2.4.2 Rise Time

The input voltages shall rise from 10% of nominal to 90% of nominal at a minimum slope of 250V/s. The smooth turn-on requires that during the 10% to 90% portion of the rise time, the slope of the turn-on waveform must be positive.



*For information about the input power sequencing of the Qseven® module, refer to the Qseven® specification.*

---

## 2.5 Power Consumption

The power consumption values listed in this section were measured under a controlled environment. The hardware used for testing includes a conga-QMX6 module, carrier board for Qseven ARM, TFT monitor, micro-SD card and USB keyboard. The carrier board was powered externally by a power supply unit so that it does not influence the power consumption value that is measured for the module. The USB keyboard was detached once the module was configured within the OS. All recorded values were averaged over a 30 second time period. The modules were cooled by the heatspreader specific to the module variants

Each module was measured while running 32 bit Linaro Ubuntu 11.10. To measure the worst case power consumption, the cooling solution was removed and the CPU core temperature was allowed to run between 95° and 100°C at 100% workload. The peak current value was then recorded. This value should be taken into consideration when designing the system's power supply to ensure that the power supply is sufficient during worst case scenarios.

Power consumption values were recorded during the following stages:

Linaro Ubuntu 11.10 (32 bit)

- Desktop Idle
- 100% CPU workload
- 100% CPU workload at approximately 100°C peak power consumption



With the Linux stress tool, we stressed the CPU to maximum frequency.

## Processor Information

The tables below provide additional information about the different variants offered by the conga-QMX6.

### 2.5.1 NXP® i.MX6 Cortex A9 1.0 GHz Single Core 512kB L2 cache

With 4GB onboard eMMC

conga-QMX6 Art. No. 016100 / 016300	NXP® i.MX6 Cortex A9 1.0 GHz 512kB L2 cache (40nm)		
Memory Size	1GB onboard		
Operating System	Ubuntu		
Power State	Desktop Idle	100% workload	Max. Power Consumption
Power consumption (measured in Ampere/Watt)	0.22 A / 1.1 W	0.34 A / 1.7 W	0.46 A / 2.3 W

### 2.5.2 NXP® i.MX6 Cortex A9 1.0 GHz Dual Lite 512kB L2 cache

With 4GB onboard eMMC

conga-QMX6 Art. No. 016101 / 016301	NXP® i.MX6 Cortex A9 1.0 GHz 512kB L2 cache (40nm)		
Memory Size	1GB onboard		
Operating System	Ubuntu		
Power State	Desktop Idle	100% workload	Max. Power Consumption
Power consumption (measured in Ampere/Watt)	0.26 A / 1.3 W	0.44 A / 2.2 W	0.66 A / 3.3 W

### 2.5.3 NXP® i.MX6 Cortex A9 1.0 GHz Dual Core 1MB L2 cache

With 4GB onboard eMMC

conga-QMX6 Art. No. 016102 / 016302	NXP® i.MX6 Cortex A9 1.0 GHz 1MB L2 cache (40nm)		
Memory Size	1GB onboard		
Operating System	Ubuntu		
Power State	Desktop Idle	100% workload	Max. Power Consumption
Power consumption (measured in Ampere/Watt)	0.28 A / 1.4 W	0.5 A / 2.5 W	0.7 A / 3.2 W

## 2.5.4 NXP® i.MX6 Cortex A9 1.0 GHz Quad Core 1MB L2 cache

With 4GB onboard eMMC

conga-QMX6 Art. No. 016103 / 016303	NXP® i.MX6 Cortex A9 1.0 GHz 1MB L2 cache (40nm)		
Memory Size	1GB onboard		
Operating System	Ubuntu		
Power State	Desktop Idle	100% workload	Max. Power Consumption
Power consumption (measured in Ampere/Watt)	0.3 A / 1.5 W	0.72 A / 3.6 W	0.92 A / 4.6 W

## 2.5.5 NXP® i.MX6 Cortex A9 1.0 GHz Quad Core 1MB L2 cache

With 4GB onboard eMMC

conga-QMX6 Art. No. 016104 / 016304	NXP® i.MX6 Cortex A9 1.0 GHz 1MB L2 cache (40nm)		
Memory Size	2GB onboard		
Operating System	Ubuntu		
Power State	Desktop Idle	100% workload	Max. Power Consumption
Power consumption (measured in Ampere/Watt)	0.3 A / 1.5 W	0.74 A / 3.7 W	0.94 A / 4.7 W

## 2.5.6 NXP® i.MX6 Cortex A9 800 MHz Single Core 512kB L2 cache (2GB eMMC)

With 2GB onboard eMMC

conga-QMX6 Art. No. 016110 / 016310	NXP® i.MX6 Cortex A9 800 MHz 512kB L2 cache (40nm)		
Memory Size	1GB onboard		
Operating System	Ubuntu		
Power State	Desktop Idle	100% workload	Max. Power Consumption
Power consumption (measured in Ampere/Watt)	0.24 A / 1.2 W	0.30 A / 1.5 W	0.48 A / 2.1 W

## 2.5.7 NXP® i.MX6 Cortex A9 800 MHz Dual Lite 512kB L2 cache (2GB eMMC)

With 2GB onboard eMMC

conga-QMX6 Art. No. 016111 / 016311	NXP® i.MX6 Cortex A9 800 MHz 512kB L2 cache (40nm)		
Memory Size	1GB onboard		
Operating System	Ubuntu		
Power State	Desktop Idle	100% workload	Max. Power Consumption
Power consumption (measured in Ampere/Watt)	TBD A / W	TBD A / W	TBD A / W

## 2.5.8 NXP® i.MX6 Cortex A9 800 MHz Dual Core 1MB L2 cache (2GB eMMC)

With 2GB onboard eMMC

conga-QMX6 Art. No. 016112 / 016312	NXP® i.MX6 Cortex A9 800 MHz 1MB L2 cache (40nm)		
Memory Size	1GB onboard		
Operating System	Ubuntu		
Power State	Desktop Idle	100% workload	Max. Power Consumption
Power consumption (measured in Ampere/Watt)	0.30 A / 1.5W	0.42 A / 2.1 W	0.60 A / 3.0 W

## 2.5.9 NXP® i.MX6 Cortex A9 800 MHz Quad Core 1MB L2 cache (2GB eMMC)

With 2GB onboard eMMC

conga-QMX6 Art. No. 016113 / 016313	NXP® i.MX6 Cortex A9 800 MHz 1MB L2 cache (40nm)		
Memory Size	1GB onboard		
Operating System	Ubuntu		
Power State	Desktop Idle	100% workload	Max. Power Consumption
Power consumption (measured in Ampere/Watt)	0.30 A / 1.5 W	0.54 A / 2.7 W	0.72 A / 3.6 W

## 2.5.10 NXP® i.MX6 Cortex A9 800 MHz Quad Core 1MB L2 cache (4GB eMMC)

With 4GB onboard eMMC

conga-QMX6 Art. No. 016318	NXP® i.MX6 Cortex A9 800 MHz 1MB L2 cache (40nm)		
Memory Size	4GB onboard		
Operating System	Ubuntu		
Power State	Desktop Idle	100% workload	Max. Power Consumption
Power consumption (measured in Ampere/Watt)	TBD A/ W	TBD A/ W	TBD A/ W



### Note

All recorded power consumption values are approximate and only valid for the controlled environment described earlier. 100% workload refers to the CPU workload and not the maximum workload of the complete module. Power consumption results will vary depending on the workload of other components such as graphics engine, memory, etc.

## 2.6 Supply Voltage Battery Power

- 2.0V-3.6V DC
- Typical 3V DC

### 2.6.1 CMOS Battery Power Consumption

RTC @ 20°C	Voltage	Current
RTC onboard the conga-QMX6 module	3V DC	1.45 µA

The CMOS battery power consumption value listed above should not be used to calculate CMOS battery lifetime. You should measure the CMOS battery power consumption in your customer specific application in worst case conditions, for example during high temperature and high battery voltage. The self-discharge of the battery must also be considered when determining CMOS battery lifetime. For more information about calculating CMOS battery lifetime, refer to [https://wiki.congatec.com/wiki/RTC\\_Battery\\_Lifetime\\_\(AN09\)](https://wiki.congatec.com/wiki/RTC_Battery_Lifetime_(AN09)).



### Note

To improve the lifetime of the CMOS battery, congatec implemented an external real-time clock onboard the conga-QMX6 module.

## 2.7 Environmental Specifications



Temperature Operation: 0° to 60°C Storage: -40° to +85°C (commercial grade variants of conga-QMX6)

---

Temperature	Operation: -40° to 85°C	Storage: -40° to +85°C (industrial grade variants of conga-QMX6)
Relative Humidity	Operation: 10% to 90%	Storage: 5% to 95%



### Caution

*The above operating temperatures must be strictly adhered to at all times. When using a congatec heat spreader, the maximum operating temperature refers to any measurable spot on the heat spreader's surface.*

*Humidity specifications are for non-condensing conditions.*

## 2.8 Storage Specifications

This section describes the storage conditions that must be observed for optimal performance of congatec products.

### 2.8.1 Module

For long-term storage of the conga-QMX6 (more than six months), keep the conga-QMX6 in a climate-controlled building at a constant temperature between 5°C and 40°C, with humidity of less than 65% and at an altitude of less than 3000 m. Also ensure the storage location is dry and well ventilated.

*We do not recommend storing the conga-QMX6 for more than five years under these conditions.*

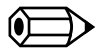

### Note

---

## 2.8.2 Cooling Solution

The heatpipes of congatec heatspreaders/cooling solutions are filled with water by default. For optimal cooling performance, do not store the heatspreaders/cooling solutions at temperatures below  $-20^{\circ}\text{C}$ .



### Caution

1. For temperatures between  $-10^{\circ}\text{C}$  and  $-20^{\circ}\text{C}$ , preheat the heatpipes before operation. Optionally, the heatpipes can be filled with acetone instead. For more information, contact your local sales representative.
2. For optimal thermal dissipation, do not store the congatec cooling solutions for more than six months.

# 3 Block Diagram

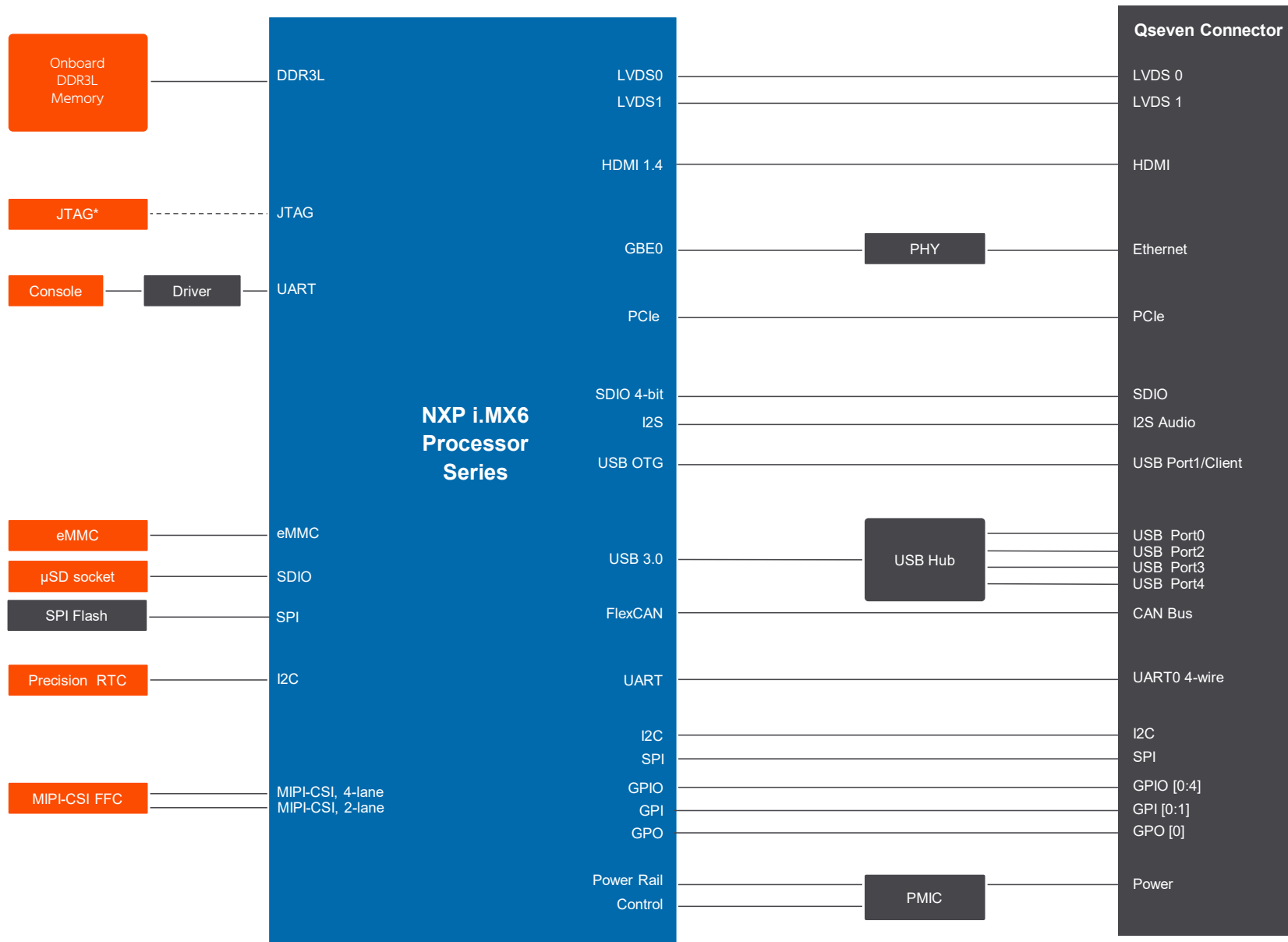

\* Assembly Option

## 4 Heatspreader

congatec GmbH offers three heatspreader variants for the conga-QMX6. Each heatspreader variant is intended for specific conga-QMX6 modules as shown in the table below. The dimensions of the cooling solutions are shown in the sub-sections. All measurements are in millimeters.

Table 8 Cooling Solution Variants

Heatspreader Variant	Heatspreader Part No. (PN)	Compatible conga-QMX6 Variants (PN)	Comment
conga-QMX6/HSP1-T	016160	016112, 016113, 016312, 016313, 016318	For modules equipped with lidded FC-PBGA CPU (1mm Gap Pad)
conga-QMX6/HSP2-T	016161	016100, 016101, 016110, 016111 016300, 016301, 016310, 016311	For modules equipped with MA-PBGA CPU (2mm Gap Pad)
conga-QMX6/HSP3-T	016162	016102, 016103, 016104, 016105, 016106 016302, 016303, 016304, 016305, 016306	For modules equipped with non-lidded FC-PBGA CPU (heatstack solution)



### Note

1. We recommend a maximum torque of 0.4 Nm for the mounting screws and to start with the two screws furthest from the CPU die.
2. The gap pad material used on congatec heatspreaders may contain silicon oil that can seep out over time depending on the environmental conditions it is subjected to. For more information about this subject, contact your local congatec sales representative and request the gap pad material manufacturer's specification.
3. Only a few NXP® iMX6 on-chip devices are enabled by default in the bootloader. With this default configuration, the conga-QMX6 power consumption is low. However, power consumption may increase significantly depending on your application and the workload of the CPU.
4. For optimal thermal dissipation, do not store the congatec cooling solutions for more than six months.



### Caution

1. The congatec heatspreaders/cooling solutions are tested only within the commercial temperature range of 0° to 60°C. Therefore, if your application that features a congatec heatspreader/cooling solution operates outside this temperature range, ensure the correct operating temperature of the module is maintained at all times. This may require additional cooling components for your final application's thermal solution.
2. For adequate heat dissipation, use the mounting holes on the cooling solution to attach it to the module. Apply thread-locking fluid on the screws if the cooling solution is used in a high shock and/or vibration environment. To prevent the standoff from stripping or cross-threading, use non-threaded carrier board standoffs to mount threaded cooling solutions.
3. For applications that require vertically-mounted cooling solution, use only coolers that secure the thermal stacks with fixing post. Without the fixing post feature, the thermal stacks may move.
4. When using the heatspreader in a high shock and/or vibration environment, congatec recommends the use of a thread-locking fluid on the heatspreader screws to ensure the above mentioned torque specification is maintained.

## 4.1 Heatspreader Dimensions

conga-QMX6/HSP1-T and HSP2-T

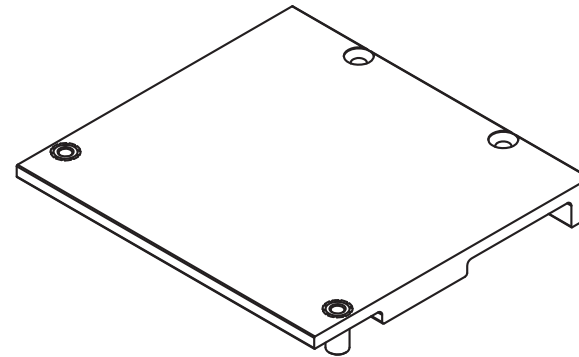
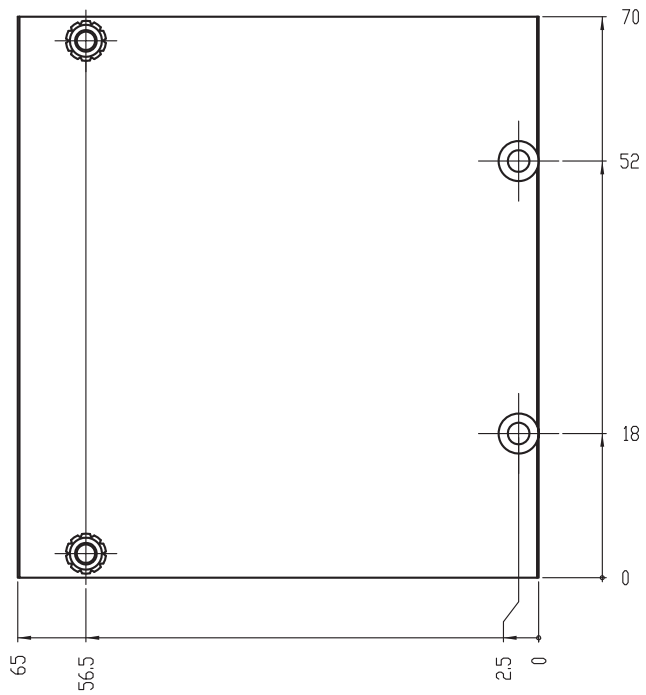
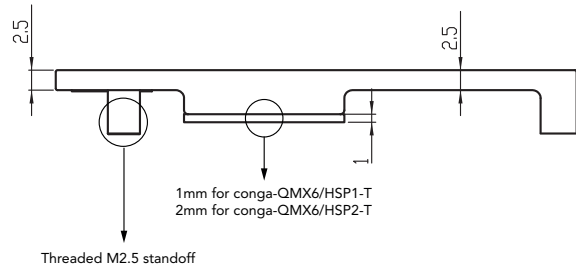

conga-QMX6/HSP3-T

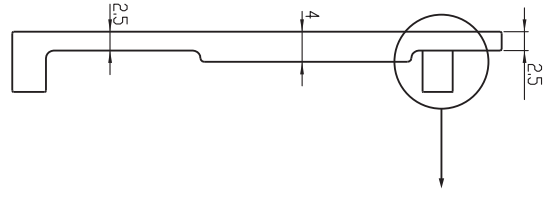

Threaded M.25 standoff

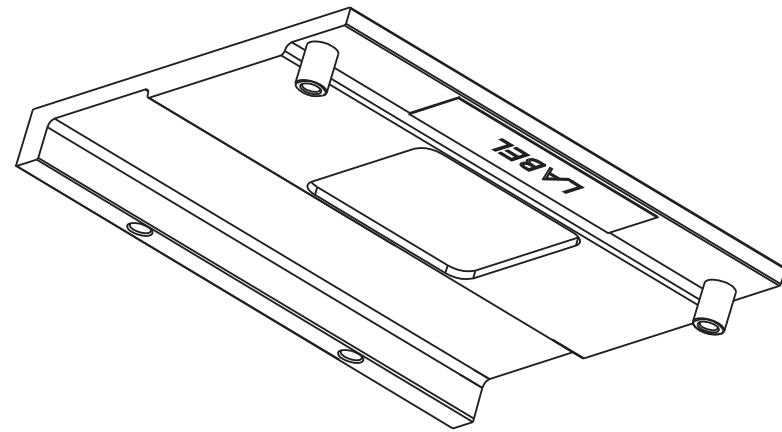
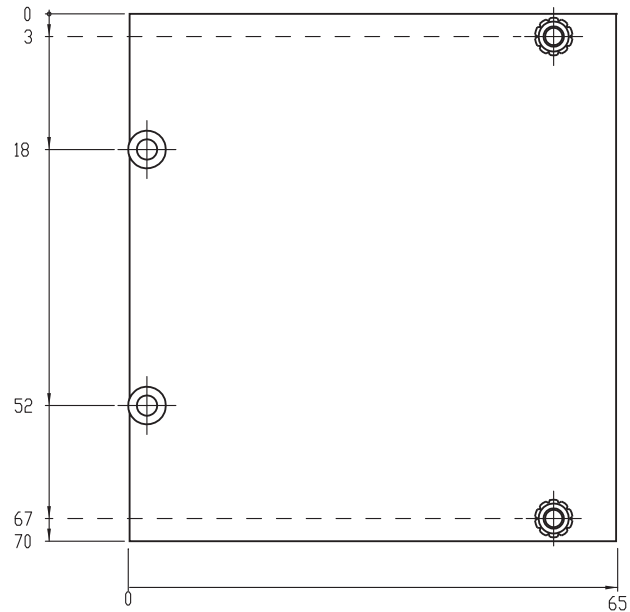
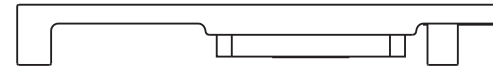

## 5 Connector Subsystems

The conga-QMX6 is based on the Qseven® standard and therefore has 115 edge fingers on the top and bottom side of the module that mate with the 230-pin card-edge MXM connector located on the carrier board. This connector provides the ability to interface the available signals of the conga-QMX6 with the carrier board peripherals.

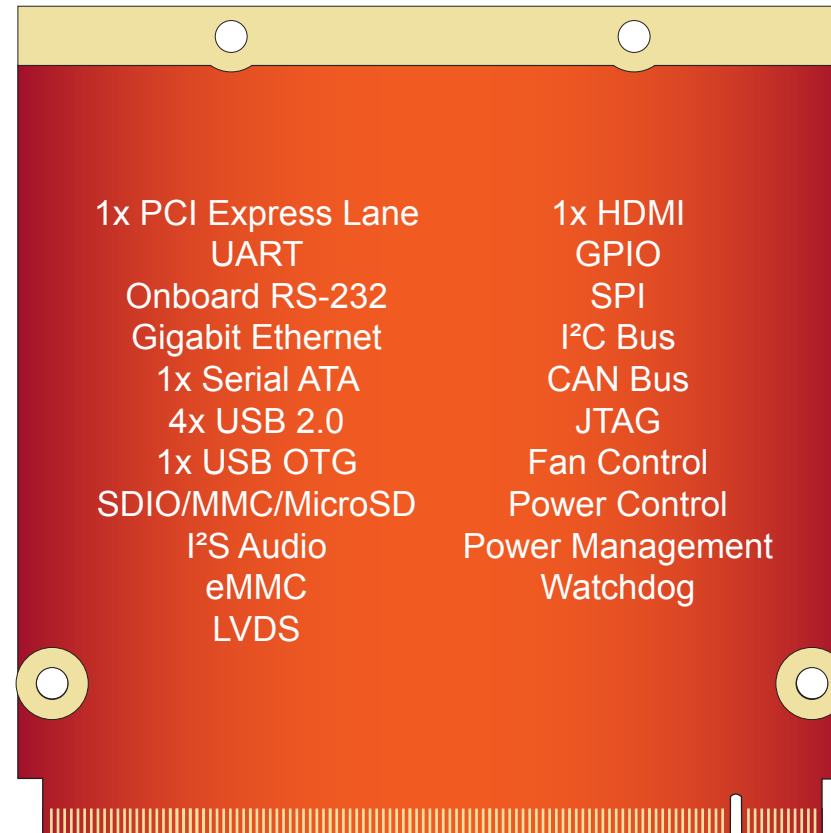

## 5.1 PCI Express

The conga-QMX6 offers one PCI Express lane. The PCIe signals are routed from the NXP® i.MX6 SoC to the PCI Express port 0 of the conga-QMX6 edge finger. The clock from the SoC limits the speed of the PCI Express interface to Gen 1. Only x1 PCI Express link configuration is possible.

For more information about the PCI Express interface on the edge finger, refer to Table 11.

## 5.2 UART/RS-232

The conga-QMX6 offers one UART interface on the MXM connector and two RS-232 interfaces onboard. The UART offered on the MXM connector is fully featured with control signals (4 pin UART) and is connected directly to UART3 port of the NXP® i.MX6 Cortex A9 processor.

The conga-QMX6 offers the two onboard RS-232 interfaces via a 6-pin Molex connector. This connector is provided by routing the UART2 and UART5 pins of the NXP® i.MX6 processor to the MAXIM-3232 transceiver. The transceiver converts the Qseven® UART CMOS level (3.3V) to RS-232 voltage levels (5v) and is guaranteed to run at data rates of 250 kbps in the normal operating mode, while maintaining RS-232 output levels. With the Molex connector, you can output data to the console by using the appropriate RS-232 adapter cable.

The UART interfaces support speeds up to 4.0 Mbps and Non-Return-To-Zero encoding format, RS-485 compatible 9 bit data format and IrDA compatible infrared slow data rate format.



### Note

*You can realize a second UART interface on the MFG interface. This implementation however requires a customized conga-QMX6 variant. Contact congatec support for more information.*

*To display the u-boot output to console, you need an RS-232 adapter cable (PN: 48000023). See section 10.1 "UART/RS-232 Debug Port" for more information about the RS-232 adapter cable and the UART pin description.*



### Caution

*The MFG\_NC4 pin is high active on the conga-QMX6 module. This means that the MFG interface on the edge connector functions as JTAG interface by default. Therefore, do not use the MFG interface for UART purposes or externally pull the MFG\_NC4 pin to ground. Failure to adhere to this warning may result to back-driving which can damage the module.*

*If you need the UART function on the MFG interface, then you require a customized conga-QMX6. For more information, contact congatec support.*

## 5.3 Gigabit Ethernet

The conga-QMX6 revision E.x offers Gigabit Ethernet with the integration of Texas Instruments DP83867. This transceiver is implemented via the RGMII interface of the i.MX6 processor. The Ethernet interface consists of 4 pairs of low voltage differential pair signals designated from GBE0\_MDI0± to GBE0\_MDI3± plus control signals for link activity indicators. These signals can be used to connect to a 10/100/1000 BaseT RJ45 connector with integrated or external isolation magnetics on the carrier board.

The conga-QMX6 revision C.x and B.x offer Gigabit Ethernet with the integration of Qualcomm Atheros Gigabit Transceiver. Earlier revisions offer Gigabit Ethernet with the integration of Micrel KSZ 9031 Ethernet PHY.



### Note

*The theoretical maximum performance of 1 Gbps Ethernet is limited to 470 Mbps (total for Tx and Rx) due to internal bus throughput limitations. The actual measured performance in optimized environment is up to 400 Mbps. For more information, consult NXP's Errata ERR004512.*

*Some signals have special functionality during the reset process. They may bootstrap some basic important functions of the module. For more information, refer to section 9.1 "Bootstrap Signals" of this user's guide.*

## 5.4 SATA

The NXP® i.MX6 Cortex A9 processor on the conga-QMX6 supports one SATA port only. The supported signals are coupled with 10nF capacitors and then routed to conga-QMX6 edge finger. The conga-QMX6 offers this SATA port on the MXM connector. This port supports SATA I (1.5Gbps) and SATA II (3Gbps) and is compliant with SATA specification 3.0, AHCI specification 1.3 and Advanced Microcontroller Bus Architecture (AMBA) specification 2.0.



### Note

*SATA interface is only supported on conga-QMX6 quad and dual core variants. Solo core and dual lite variants do not support SATA.*

---

## 5.5 USB 2.0

The conga-QMX6 offers five USB ports via USB 2.0 host controllers provided by the NXP® i.MX6 Cortex A9 processor. These controllers provide high performance USB functionality that complies with USB 2.0 specification and with OTG supplement.

The offered ports comprise of one USB OTG port and four USB hosts. These four USB hosts are derived through the integration of an SMSC USB hub, and are implemented by routing the USB H1 port of the processor to the SMSC Hub. The USB OTG port (OTG client) is connected directly to the USB\_OTG port of the i.MX6 processor.

The OTG client port can drop the hosting role and act as a normal USB device when conga-QMX6 is attached to another host. The direction of OTG port depends on the USB control signal (USB\_ID). If asserted high, the OTG is set to client and if low, the OTG port is set to host. All ports are capable of supporting USB 1.1 and 2.0 compliant devices.

## 5.6 SD/SDIO/MMC

SDIO stands for Secure Digital Input Output. Devices that support SDIO can use small devices such as SD-Card or MMC-Card flash memories. The SD/SDIO/MMC cards communicate with the host system via the Ultra Secured Digital Host Controller (uSDHC). This controller acts as a bridge by sending commands and accessing data to and from the cards. The NXP® i.MX6 processor on the conga-QMX6 provides SD/SDIO/MMC controllers (SD1-SD4) for communicating with different SD, SDIO and MMC devices.

The conga-QMX6 offers one SDIO interface on the MXM connector via the NXP® i.MX6 SD4 port. Two other SDIO ports provided by the NXP® i.MX6 processor are supported onboard the conga-QMX6. These ports (SD2 and SD3) connect the onboard 4 bit micro SD and the onboard 8 bit eMMC respectively

The SDIO ports support SDIO Revision 1.1, SD Memory Card Specification Revision 3.0 and MMC Revision 4.4.

## 5.7 HDA/I2S/AC'97

The conga-QMX6 uses the I2S format for audio signals. These signals are derived from the Synchronous Serial Interface (SSI) of the NXP® i.MX6 processor. The SSI is a full duplex serial port that allows communication with external devices using a variety of serial protocols. The I2S protocol is part of the protocols supported by the NXP® i.MX6 Cortex A9 processor. The SSI supports up to 1.4 Mbps.



*The conga-QMX6 currently supports only I2S format.*

## 5.8 LVDS

The LVDS Display Bridge (LDB) from the NXP® i.MX6 Cortex A9 processor found on the conga-QMX6 offers two LVDS channels, with up to 170 Mhz pixel clock. Each channel consists of one clock pair and four data pairs. The LDB supports the flow of synchronous RGB data from the Image Processing Unit (IPU) to external display devices through LVDS interface.

The LVDS interface supports 18 bit and 24 bit dual channel. The LVDS interface also supports various resolutions but with stipulated maximum data rates. The data rates supported are as follows:

For single channel output: Up to 85 MHz per interface (e.g 1366x768 @ 60 Hz + 35 % blanking).

For dual channel output: Up to 170 MHz pixel clock (e.g 1600x1200 @ 60Hz + 35 % blanking)

The LVDS ports support the following configurations:

- One single channel output
- One dual channel output single input split to two output channels
- Two identical outputs: single input sent to both output channels
- Two independent outputs: two inputs sent, each to a different output channel



### Note

*The LVDS interface can be configured as a single channel, a dual channel or as two independent single LVDS channels. The actual configuration depends on the Operating System. For more information, contact congatec technical solution center.*

*Three independent displays are possible when connected as two single LVDS channel and one HDMI interface.*

## 5.9 HDMI®

High-Definition Multimedia Interface (HDMI®) is a licensable compact audio/video connector interface for transmitting uncompressed digital streams. HDMI® encodes the video data into TMDS for digital transmission and is backward-compatible with the single-link Digital Visual Interface (DVI) carrying digital video.

The conga-QMX6 provides HDMI® connection directly from the NXP® i.MX6 processor. Video data is provided through three differential TMDS data pairs (TMDS\_LANE0± to TMDS\_LANE2±) and one differential clock pair (TMDS\_CLK±). In addition, the conga-QMX6 includes one standard I2C interface (I2C2\_SDA and I2C2\_SCL) for configuring and testing the HDMI 3D Tx PHY and a pin (DP\_HDMI\_HPD) for HDMI® hot plug detection support.

---

## 5.10 LPC/GPIO

The conga-QMX6 does not support the Low Pin Count (LPC) signals, instead eight GPIO pins shared with the LPC pins according to Qseven specification 2.0 are supported.

The General Purpose Input/Output pins can be configured as inputs or outputs. When configured as output, it is possible to write to an internal register to control the state driven on the output pin. When configured as input, the input state can be detected by reading the status of an internal register. To select the GPIO mode, configure the IOMUX.

## 5.11 SPI

The NXP® i.MX6 processor provides Enhanced Configurable Serial Peripheral Interfaces (ECSPIs) capable of up to 66 Mbps write speed and 31 Mbps read speed. The ECSPI interfaces offer full-duplex, synchronous serial interface with maximum operation frequency up to the reference clock frequency. It can be configured to support Master/Slave modes and four chip selects to support multiple peripherals.

The conga-QMX6 offers one SPI interface on the edge finger connector. Another SPI interface from the NXP® i.MX6 processor is connected to the 32 Mbit SPI Flash memory onboard the conga-QMX6. The NXP® i.MX6 processor is programmed to boot from the bootloader contained in the SPI flash memory.

## 5.12 CAN Bus

The conga-QMX6 supports CAN bus. The CAN controller performs communication in accordance with the CAN Protocol Version 2.0B Active1 (standard format and extended format). The bit rate can be programmed to a maximum of 1 Mbit/s, based on the technology used. To connect the CAN controller module to the CAN bus, it is necessary to add transceiver hardware. A complete description of the CAN controller registers and functionality is beyond the scope of this user's guide. Consult NXP's i.MX6 processor reference manual for additional information about this interface.

## 5.13 Manufacturing/JTAG Interface

The manufacturing signals defined in Qseven Specification 2.0 are reserved for either manufacturing or debugging purposes. The conga-QMX6 offers this interface as a 10-pin JTAG interface, for debugging purposes. This interface is connected to the JTAG controller of the NXP® i.MX6 processor. The JTAG control fuses are used to allow or disallow JTAG access to secured resources.



*For compatible JTAG adapters, contact the congatec support team or order the Nit6X\_JTAG from Boundary Devices.*

## 5.14 Power Control

### PWGIN

The PWGIN (pin 26) can be connected to an external power good circuit or it may also be utilized as a manual reset input. To use PWGIN as a manual reset input, the pin must be grounded through the use of a momentary-contact push-button switch. When external circuitry asserts this signal, it is necessary that an open-drain driver drives this signal causing it to be held low for a minimum of 16ms to initiate a reset. Using this input is optional. For more information, see the note below.

### SUS\_S3#

The SUS\_S3# (pin 18) signal shuts off power to all runtime system components that are not maintained during suspend mode. This signal is an output signal and is connected to the Power Management Integrated Circuit (PMIC). See Table 26 for more information.

### PWRBTN#

When using ATX-style power supplies, PWRBTN# (pin 20) is used to connect to a momentary-contact, active-low debounced push-button input while the other terminal on the push-button must be connected to ground. This signal is internally pulled up to 3V\_SB using a 10k resistor. When PWRBTN# is asserted it indicates that an operator wants to turn the power on or off.



### Note

*The conga-QMX6 boots up immediately power is applied to the module's +5v input rail. To shutdown the system, use the the linux command "poweroff". Depending on the operating system, the shutdown can also be performed by pressing the power button. If the system is in shutdown or standby state, pressing the power button restores the system back to full-on state. When the chip main power supply is Off, a button press greater in duration than 750 ms asserts an output signal to request power from a power IC to power up the SoC.*

*If it's desired to keep the system switched off even when the +5V input power rail is initially powered on (ATX-style), an external logic has to be used that prevents the system from booting by means of the power good signal (PWGIN). It is the responsibility of the external logic to release the PWGIN signal, when the desired event (e.g. pressing the power button) occurs.*

## Power Supply Implementation Guidelines

5 volt input power is the sole operational power source for the conga-QMX6. The remaining necessary voltages are internally generated on the module using onboard voltage regulators. When designing a power supply for a conga-QMX6 application, a carrier board designer should be aware of the important information below:

- It has been noticed that on some occasions, problems occur when using a 5V power supply that produces non monotonic voltage when powered up. The problem is that some internal circuits on the module (e.g. clock-generator chips) will generate their own reset signals when the supply voltage exceeds a certain voltage threshold. A voltage dip after passing this threshold may lead to these circuits becoming confused resulting in a malfunction. It must be mentioned that this problem is quite rare but has been observed in some mobile power supply applications. The best way to ensure that this problem is not encountered is to observe the power supply rise waveform through the use of an oscilloscope to determine if the rise is indeed monotonic and does not have any dips. This should be done during the power supply qualification phase therefore ensuring that the above mentioned problem doesn't arise in the application. For more information, see the "Power Supply Design Guide for Desktop Platform Form Factors" document at [www.intel.com](http://www.intel.com).

### Inrush and Maximum Current Peaks on VCC\_5V\_SB and VCC

The inrush-current on the conga-QMX6 VCC\_5V\_SB power rail can go up as high as 2.3A for a maximum of 100µS. Sufficient decoupling capacitance must be implemented to ensure proper power-up sequencing. The maximum peak-current on the conga-QMX6 VCC (5V) power rail can be as high as 3.0A. This requires that the power supply be properly dimensioned.



#### Note

*For more information about power control event signals refer to the Qseven® specification.*

## 5.15 Power Management

Onboard the conga-QMX6 is a 14 channel configurable Power Management Integrated Circuit (PMIC). The PMIC provides a cost effective programmable power management solution for a wide range of applications. This high efficiency, configurable power management IC is designed to work seamlessly with NXP® processors. The NXP® i.MX6 cortex A9 processor uses advanced integration Power Management Unit (PMU) to reduce supply connections. The PMIC complements the processor's internal regulators in providing a complete and simple way to supply voltage domain with different voltages when needed.

The PMIC features four bulk regulators (up to six independent outputs), one boost regulator, six general purpose LDOs, one switch/LDO combination and a DDR voltage reference to supply voltages for the application processor and peripheral devices.

With integrated memory power, RTC supply and additional bulk and linear regulators to power system peripherals, multiple point of power supply across the PCB is drastically reduced.

---

## 5.16 Watchdog

The watchdog timer (WDOG) protects against system failures by providing a method of escaping from unexpected events or programming errors. The software must periodically service the watchdog timer once the WDOG is activated. Without the servicing, the timer times out.

The NXP® i.MX6 processor on the conga-QMX6 offers two watchdog timers - a watchdog timer integrated within the ARM Cortex A9 platform and a TrustZone watchdog timer.

## 5.17 I2C Bus

The I2C bus is suitable for applications requiring occasional communications over a short distance between many devices. The I2C interfaces offered by the NXP® i.MX6 processor support up to 400 kbps, depending on pin loading and timing characteristics

The conga-QMX6 offers three I2C interfaces (I2C1, I2C2 and I2C3) on the Qseven edge connector. The I2C2 and I2C3 buses on the edge connector are shared with some onboard devices - I2C3 is shared with LVDS and RTC while I2C2 is shared with camera interface and HDMI®. The I2C1 bus is routed directly without sharing on the edge connector.



### Note

*On the conga-QMX6 revision B.x and later, we implemented a multiplexer on the I2C2 interface. The multiplexer separates the PMIC functions from other devices (camera, HDMI®) that share the bus. Due to this implementation, the user needs to download the latest kernel from [git.congatec.com/public](http://git.congatec.com/public) or at least ensure the congatec I2C multiplexer patches (CGT000031, CGT000032) are applied to the desired kernel, to achieve proper behaviour.*

*The I2C3 is also available on the SMBus signals (pin 60 and 62) of the Qseven edge connector.*

---

## 6 Additional Features

---

### 6.1 High Assurance Boot (HAB)

The High Assurance Boot is a software library executed in internal ROM on the NXP® processor at boot time, which among other things, authenticates software in external memory by verifying digital signatures. The HAB enables the ROM to authenticate software which executes immediately after ROM, by using digital signatures. This software is usually a bootloader. The High Assurance Boot component of the ROM protects against the potential threat of attackers modifying areas of code or data in programmable memory to make it behave in an incorrect manner.

### 6.2 Dedicated Hardware Accelerators

The NXP® i.MX6 processor uses dedicated hardware accelerators to meet the targeted multimedia performance. The use of hardware accelerators is a key factor in obtaining high performance at low power consumption while having the CPU core relatively free for performing other tasks. The hardware accelerators available in the processor are VPU, IPUv3H, 3D GPU, 2D GPU, OpenVG 1.1 GPU and Asynchronous Sample Rate Converter (ASRC).

### 6.3 Power Management

The NXP® i.MX6 processor integrates power management functions to simplify system power management requirements. The processor provides power management units for offering power to various Soc domains. Temperature sensor for monitoring the die temperature is also provided.

Dynamic Voltage and Frequency Scaling techniques, software state retention, power gating and various levels of system power mode are supported. The use of simple and low-cost power regulators in place of complicated external power management ICs reduces system design cost.

### 6.4 Dynamic Voltage and Frequency Scaling

Dynamic Voltage and Frequency Scaling is a power management technique used in changing the clock frequency and/or the operating voltage of a processor based on system performance requirements at any point in time. This scaling is normally carried out during less demanding periods of nominal run speed. In General, it helps in balancing the performance demands of processor with the high amount of power needed to satisfy those demands.

---

## 6.5 Smart Speed Technology

The NXP's Smart Speed Technology with enhanced Cycles Per Instruction (eCPI) determines the speed of the processor by the set of tasks to be performed instead of the clock speed. The set of tasks determines the execution units needed to make sure the system work more efficiently. This ensures that the system provides enough performance without wasting resources.

With the Smart Speed Technology, several execution units work in parallel, thereby providing higher processor speed at lower power consumption. System parallelism is accomplished via the Smart Speed crossbar switch that nearly eliminates wait states. This results in improved processor performance without power consumption penalty associated with higher operating frequencies.

By employing Smart Speed Technology, portable devices can run longer, retain smaller form factors and support more innovative applications without substantially increasing the battery power.

## 6.6 Suspend Mode

The Suspend Mode feature is available on the conga-QMX6.

---

# 7 ARM Technologies

---

## 7.1 Media Processing Engine (MPE-NEON)

The Media Processing Engine (MPE-NEON) is a single instruction multiple data (SIMD) instruction set that provides flexible and powerful acceleration for media and signal processing applications. Support for a wide range of multimedia codecs with fewer cycles helps in enhancing user experience. NEON is used for multimedia data processing.

## 7.2 Jazelle DBX

The Jazelle is an instruction set that introduces technological infrastructure for running java codes faster than the software based java virtual machine. The Jazelle DBX (Direct Bytecode eXecution) enabled cores execute the majority of Java bytecodes in hardware. No modification is required in the application code to take advantage of this technology. To configure and turn on the Jazelle DBX, the software support code needs to be integrated into a Java Virtual Machine (JVM). Contact ARM for further information on how to obtain the software support code.

## 7.3 TrustZone

The ARM TrustZone technology is a security extension that provides additional dedicated security to a System on Chip (SoC). This technology aims to provide a framework that enables a device to counter many of the specific threats that it will experience. The security of the system is achieved by partitioning all of the SoC's hardware and software resources so that they exist in one of two worlds - the secure world (more trusted) and the normal world (less trusted). The memory and peripherals are then made aware of the operating world of the core and may use this to provide access control to secrets and code in the device.

## 7.4 Floating Point Unit

The Floating Point Unit (FPU) provides significant acceleration for both single and double precision scalar Floating-Point operations. It provides industry leading image processing, graphics and scientific computation capabilities. The FPU provides an optimized solution in performance, power and area for embedded applications and high performance for general purpose applications.

---

## 8 conga Tech Notes

---

The conga-QMX6 has some technological features that require additional explanation. The following section will give the reader a better understanding of some of these features.

### 8.1 NXP® i.MX6 Processor Features

#### 8.1.1 Temperature Monitor (TEMPMON)

The NXP® i.MX6 Cortex A9 processors have a temperature sensor module that implements a temperature sensor/conversion function based on a temperature-dependent voltage to time conversion.

The module features an alarm function that can raise an interrupt signal if the temperature is above a specified threshold. A self repeating mode can also be programmed which executes a temperature sensing operation based on a programmed delay.

Software can use this module to monitor the on-die temperature and take appropriate actions such as throttling back the core frequency when a temperature interrupt is set.

During normal system operation, software can use the temperature sensor counter output in conjunction with the fused temperature calibration data to determine the on-die operational temperature or to set an over-temperature interrupt alarm to within a couple of degree centigrade.

### 8.2 Thermal Management

To meet low power design requirement while maintaining a high performance operation, the NXP® iMX6 incorporated several low power design techniques. Even with these techniques, it is vital to manage the heat dissipation of the module in accordance with internal and external conditions.

The conga-QMX6 employs basically two types of thermal management strategies:

#### **Active Cooling**

During this cooling policy, the operating system turns the fan on/off. Though the active thermal management technique provides better heat dissipation and lower thermal resistances, the cooling solutions are however expensive and have large form factors.

---

## Passive Cooling

The passive cooling policy employs the technique of enhancing conduction and natural convection. This passive thermal management procedure provides cost effective cooling solutions up to certain power levels without introducing reliability concerns. Some of these techniques typically used are thermal gap fillers, heatspreaders and heat shields.

## 8.3 Audio Mux

Audio Mux (AUDMUX) is one of the modules found in the audio subsystem of the NXP® i.MX6 processor. It provides flexible programmable routing of the on-chip serial interfaces to and from off-chip devices. The AUDMUX includes internal port that connect to the processor serial interfaces and external ports that connect to off-chip audio devices. Connection is established by configuring the appropriate host and peripheral ports. Though controlled by ARM, the AUDMUX can route data even when the ARM is in a low-power mode.

## 8.4 LVDS Bridge

The LVDS Bridge (LDB) supports the flow of synchronous RGB data from the Image Processing Unit to external devices through LVDS interface. This support includes synchronization and control capabilities, connectivity to relevant devices as well as proper data arrangement as required by the external display receiver and by LVDS display standards.

## 8.5 USB Port Connections

The conga-QMX6 offers a total of 5 USB ports (one USB OTG port and four Host-only ports). The four Host-only ports found on the conga-QMX6 are implemented by routing one Host-only port (USB H1) from the NXP® i.MX6 processor to the conga-QMX6 edge finger via a SMSC USB Hub.

The USB\_OTG port (OTG client) of the conga-QMX6 is routed directly to the USB\_OTG port of the i.MX6 processor. This port can drop the hosting role and act as a normal USB device when conga-QMX6 is attached to another host. It is also used as a downstream and upstream port while the Host-only cores are used as downstream ports.

For more information refer to the conga-QMX6 USB routing diagram shown below:

# conga-QMX6 USB Routing Diagram

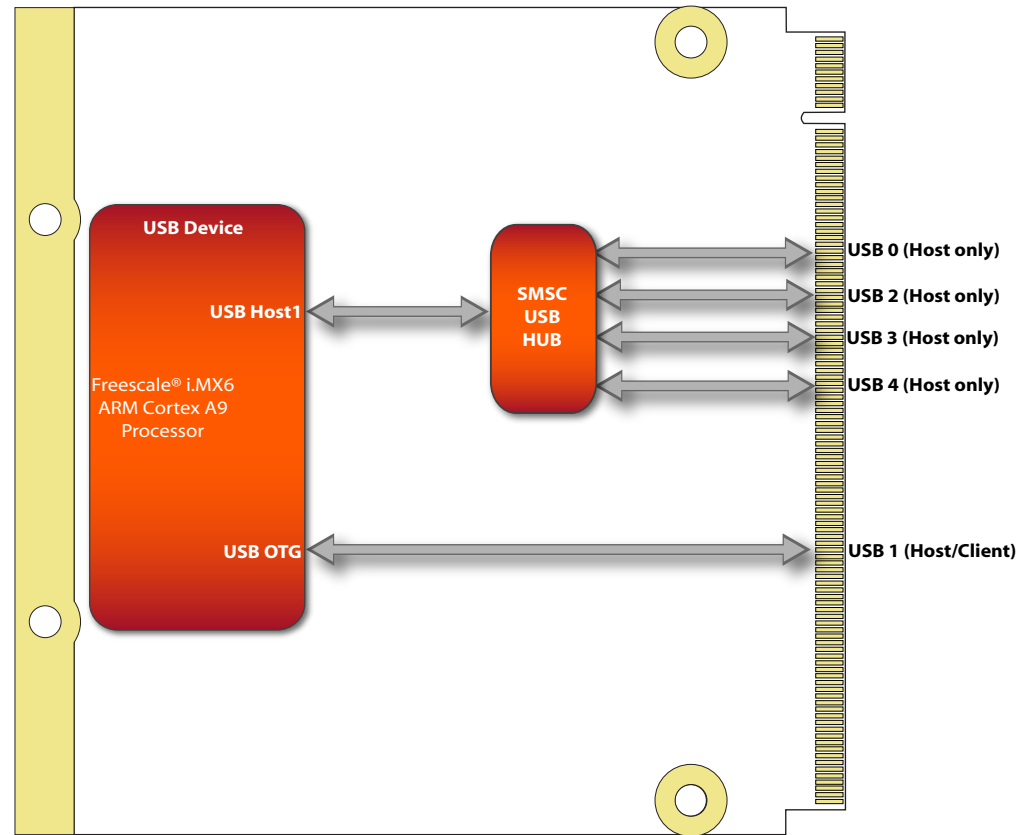

## 9 Interface - Signal Descriptions and Pinout Tables

The following section describes the signals found on Qseven® module's edge fingers and the interfaces implemented on the conga-QMX6.

The table below describes the terminology used in this section for the Signal Description tables. The PU/PD column indicates if a Qseven® module pull-up or pull-down resistor has been used, if the field entry area in this column for the signal is empty, then no pull-up or pull-down resistor has been implemented by congatec. The “#” symbol at the end of the signal name indicates that the active or asserted state occurs when the signal is at a low voltage level. When “#” is not present, the signal is asserted when at a high voltage level.



*The Signal Description tables do not list internal pull-ups or pull-downs implemented by the chip vendors, only pull-ups or pull-downs implemented by congatec are listed. For information about the internal pull-ups or pull-downs implemented by the chip vendors, refer to the respective chip's datasheet.*

*Not all the signals described in this section are available on all conga-QMX6 variants. Use the article number of the module and refer to the options table on page 8 to determine the options available on the module.*

Table 9 Signal Tables Terminology Descriptions

Term	Description
I	Input pin
O	Output pin
OC	Open collector
OD	Open drain
PP	Push pull
I/O	Bi-directional Input/Output Pin
3.3VSB	3.3V tolerant active in standby state
P	Power input
NA	Not applicable
NC	Not connected
PCIE	PCI Express differential pair signals. In compliance with the PCI Express Base Specification 1.0a.
GB_LAN	Gigabit Ethernet Media Dependent Interface differential pair signals. In compliance with IEEE 802.3ab 1000Base-T Gigabit Ethernet Specification.
USB	Universal Serial Bus differential pair signals. In compliance with the Universal Serial Bus Specification 2.0
SATA	Serial Advanced Technology Attachment differential pair signals. In compliance with the Serial ATA High Speed Serialized AT Attachment Specification 1.0a.
SPI	Serial Peripheral Interface bus is a synchronous serial data link that operates in full duplex mode.
CAN	Controller Area Network bus is a vehicle bus standard that allows microcontrollers and devices to communicate with each other within a vehicle without a host computer.
LVDS	Low-Voltage Differential Signaling differential pair signals. In compliance with the LVDS Owner's Manual 4.0.
TMDS	Transition Minimized Differential Signaling differential pair signals. In compliance with the Digital Visual Interface (DVI) Specification 1.0.
CMOS	Logic input or output.

Table 10 Edge Finger Pinout

Pin	Signal	Pin	Signal
1	GND	2	GND
3	GBE_MDI3-	4	GBE_MDI2-
5	GBE_MDI3+	6	GBE_MDI2+
7	GBE_LINK100#	8	GBE_LINK1000#
9	GBE_MDI1-	10	GBE_MDI0-
11	GBE_MDI1+	12	GBE_MDI0+
13	GBE_LINK#	14	GBE_ACT#
15	GBE_CTREF (*)	16	SUS_S5#
17	WAKE#	18	SUS_S3#
19	SUS_STAT#*	20	PWRBTN#
21	SLP_BTN#	22	LID_BTN#
23	GND	24	GND
25	GND	26	PWGIN
27	BATLOW#	28	RSTBTN#
29	SATA0_TX+	30	SATA1_TX+ (*)
31	SATA0_TX-	32	SATA1_TX- (*)
33	SATA_ACT#	34	GND
35	SATA0_RX+	36	SATA1_RX+ (*)
37	SATA0_RX-	38	SATA1_RX- (*)
39	GND	40	GND
41	BIOS_DISABLE# / BOOT_ALT#	42	SDIO_CLK
43	SDIO_CD#	44	SDIO_LED
45	SDIO_CMD	46	SDIO_WP
47	SDIO_PWR#	48	SDIO_DAT1
49	SDIO_DAT0	50	SDIO_DAT3
51	SDIO_DAT2	52	SDIO_DAT5
53	SDIO_DAT4	54	SDIO_DAT7
55	SDIO_DAT6	56	USB_DRIVE_VBUS
57	GND	58	GND
59	HDA_SYNC / I2S_WS	60	SMB_CLK / GP1_I2C_CLK
61	HDA_RST# / I2S_RST#	62	SMB_DAT / GP1_I2C_DAT
63	HDA_BITCLK / I2S_CLK	64	SMB_ALERT#
65	HDA_SDI / I2S_SDI	66	GP0_I2C_CLK
67	HDA_SDO / I2S_SDO	68	GP0_I2C_DAT
69	THRM#	70	WDTRIG#
71	THRMTRIP#	72	WDOUT
73	GND	74	GND
75	USB_P7- / USB_SSTX0-	76	USB_P6- / USB_SSRX0-
77	USB_P7+ / USB_SSTX0+	78	USB_P6+ / USB_SSRX0+

Pin	Signal	Pin	Signal
79	USB_6_7_OC#	80	USB_4_5_OC#
81	USB_P5- / USB_SSTX1-	82	USB_P4- / USB_SSRX1-
83	USB_P5+ / USB_SSTX1+	84	USB_P4+ / USB_SSRX1+
85	USB_2_3_OC#	86	USB_0_1_OC#
87	USB_P3-	88	USB_P2-
89	USB_P3+	90	USB_P2+
91	USB_VBUS	92	USB_ID
93	USB_P1-	94	USB_P0-
95	USB_P1+	96	USB_P0+
97	GND	98	GND
99	eDP0_TX0+ / LVDS_A0+	100	eDP1_TX0+ / LVDS_B0+
101	eDP0_TX0- / LVDS_A0-	102	eDP1_TX0- / LVDS_B0-
103	eDP0_TX1+ / LVDS_A1+	104	eDP1_TX1+ / LVDS_B1+
105	eDP0_TX1- / LVDS_A1-	106	eDP1_TX1- / LVDS_B1-
107	eDP0_TX2+ / LVDS_A2+	108	eDP1_TX2+ / LVDS_B2+
109	eDP0_TX2- / LVDS_A2-	110	eDP1_TX2- / LVDS_B2-
111	LVDS_PPEN	112	LVDS_BLEN
113	eDP0_TX3+ / LVDS_A3+	114	eDP1_TX3+ / LVDS_B3+
115	eDP0_TX3- / LVDS_A3-	116	eDP1_TX3- / LVDS_B3-
117	GND	118	GND
119	eDP0_AUX+ / LVDS_A_CLK+	120	eDP1_AUX+ / LVDS_B_CLK+
121	eDP0_AUX- / LVDS_A_CLK-	122	eDP1_AUX- / LVDS_B_CLK-
123	LVDS_BLT_CTRL / GP_PWM_OUT0	124	GP_1-Wire_Bus
125	GP2_I2C_DAT / LVDS_DID_DAT	126	eDP0_HPD# / LVDS_BLC_DAT
127	GP2_I2C_CLK / LVDS_DID_CLK	128	eDP1_HPD# / LVDS_BLC_CLK
129	CAN0_TX	130	CAN0_RX
131	DP_LANE3+ / TMDS_CLK+	132	RSVD (Differential Pair)
133	DP_LANE3- / TMDS_CLK-	134	RSVD (Differential Pair)
135	GND	136	GND
137	DP_LANE1+ / TMDS_LANE1+	138	DP_AUX+
139	DP_LANE1- / TMDS_LANE1-	140	DP_AUX-
141	GND	142	GND
143	DP_LANE2+ / TMDS_LANE0+	144	RSVD (Differential Pair)
145	DP_LANE2- / TMDS_LANE0-	146	RSVD (Differential Pair)
147	GND	148	GND
149	DP_LANE0+ / TMDS_LANE2+	150	HDMI_CTRL_DAT
151	DP_LANE0- / TMDS_LANE2-	152	HDMI_CTRL_CLK
153	DP_HDMI_HPD#	154	RSVD
155	PCIE_CLK_REF+	156	PCIE_WAKE#
157	PCIE_CLK_REF-	158	PCIE_RST#

Pin	Signal	Pin	Signal
159	GND	160	GND
161	PCIE3_TX+	162	PCIE3_RX+
163	PCIE3_TX-	164	PCIE3_RX-
165	GND	166	GND
167	PCIE2_TX+	168	PCIE2_RX+
169	PCIE2_TX-	170	PCIE2_RX-
171	UART0_TX	172	UART0_RTS# (optionally, UART0_CTS#)
173	PCIE1_TX+	174	PCIE1_RX+
175	PCIE1_TX-	176	PCIE1_RX-
177	UART0_RX	178	UART0_CTS# (optionally, UART0_RTS#)
179	PCIE0_TX+	180	PCIE0_RX+
181	PCIE0_TX-	182	PCIE0_RX-
183	GND	184	GND
185	LPC_AD0 / GPIO0	186	LPC_AD1 / GPIO1
187	LPC_AD2 / GPIO2	188	LPC_AD3 / GPIO3
189	LPC_CLK / GPIO4	190	LPC_FRAME# / GPIO5
191	SERIRQ / GPIO6	192	LPC_LDRQ# / GPIO7
193	VCC_RTC	194	SPKR / GP_PWM_OUT2
195	FAN_TACHOIN / GP_TIMER_IN	196	FAN_PWMOUT / GP_PWM_OUT1
197	GND	198	GND
199	SPI_MOSI	200	SPI_CS0#
201	SPI_MISO	202	SPI_CS1#
203	SPI_SCK	204	MFG_NC4
205	VCC_5V_SB	206	VCC_5V_SB
207	MFG_NC0	208	MFG_NC2
209	MFG_NC1	210	MFG_NC3
211	VCC	212	VCC
213	VCC	214	VCC
215	VCC	216	VCC
217	VCC	218	VCC
219	VCC	220	VCC
221	VCC	222	VCC
223	VCC	224	VCC
225	VCC	226	VCC
227	VCC	228	VCC
229	VCC	230	VCC



*The conga-QMX6 does not support the signals marked with asterisk symbol (\*).*

Table 11 PCI Express Signal Descriptions

Signal	Pin #	Description	I/O	PU/PD	Comment
PCIE0_RX+ PCIE0_RX-	180 182	PCI Express channel 0, Receive Input differential pair.	I PCIE		Supports PCI Express Base Specification, Revision 1.0a.
PCIE0_TX+ PCIE0_TX-	179 181	PCI Express channel 0, Transmit Output differential pair.	O PCIE		Supports PCI Express Base Specification, Revision 1.0a.
PCIE1_RX+ PCIE1_RX-	174 176	PCI Express channel 1, Receive Input differential pair.	I PCIE		Not supported.
PCIE1_TX+ PCIE1_TX-	173 175	PCI Express channel 1, Transmit Output differential pair.	O PCIE		Not supported.
PCIE2_RX+ PCIE2_RX-	168 170	PCI Express channel 2, Receive Input differential pair.	I PCIE		Not supported.
PCIE2_TX+ PCIE2_TX-	167 169	PCI Express channel 2, Transmit Output differential pair.	O PCIE		Not supported.
PCIE3_RX+ PCIE3_RX-	162 164	PCI Express channel 3, Receive Input differential pair.	I PCIE		Not supported.
PCIE3_TX+ PCIE3_TX-	161 163	PCI Express channel 3, Transmit Output differential pair.	O PCIE		Not supported.
PCIE_CLK_REF+ PCIE_CLK_REF-	155 157	PCI Express Reference Clock Signals for Lanes 0 to 3.	O PCIE		The clock from the SoC limits the speed of the PCI Express interface to Gen 1.
PCIE_WAKE#	156	PCI Express Wake Event: Sideband wake signal asserted by components requesting wakeup.	I 3.3VSB	PU 1k 3.3VSB	Connected to GPIO
PCIE_RST#	158	Reset Signal for external devices.	O 3.3V		

Table 12 UART Signal Descriptions

Signal	Pin #	Description	I/O	PU/PD	Comment
UART0_TX	171	Serial Data Transmitter	O 3.3V		UART3_TX signal from Processor
UART0_RX	177	Serial Data Reciever	I 3.3V		UART3_RX signal from Processor
UART0_CTS#	178	Handshake signal, ready to send data	I 3.3V		UART3_CTS# signal from Processor
UART0_RTS#	172	Handshake signal, ready to receive data	O 3.3V		UART3_RTS# signal from Processor



*The UART0\_CTS# and UART0\_RTS# signals are switched in revisions A.x and B.x. The switched signals have been corrected in revision C.x and E.x. Optionally, the signals can be switched back to their incorrect configuration (assembly option).*

Table 13 Ethernet Signal Descriptions

Signal	Pin #	Description	I/O	PU/PD	Comment
GBE_MDI0+ GBE_MDI0-	12 10	Media Dependent Interface (MDI) differential pair 0. The MDI can operate in 1000, 100, and 10Mbit/sec modes. This signal pair is used for all modes.	I/O Analog		Twisted pair signals for external transformer.
GBE_MDI1+ GBE_MDI1-	11 9	Media Dependent Interface (MDI) differential pair 1. The MDI can operate in 1000, 100, and 10Mbit/sec modes. This signal pair is used for all modes.	I/O Analog		Twisted pair signals for external transformer.
GBE_MDI2+ GBE_MDI2-	6 4	Media Dependent Interface (MDI) differential pair 2. The MDI can operate in 1000, 100, and 10Mbit/sec modes. This signal pair is only used for 1000Mbit/sec Gigabit Ethernet mode.	I/O Analog		Twisted pair signals for external transformer.
GBE_MDI3+ GBE_MDI3-	5 3	Media Dependent Interface (MDI) differential pair 3. The MDI can operate in 1000, 100, and 10Mbit/sec modes. This signal pair is only used for 1000Mbit/sec Gigabit Ethernet mode.	I/O Analog		Twisted pair signals for external transformer.
GBE_CTREF	15	Reference voltage for carrier board Ethernet channel 0 magnetics center tap. The reference voltage is determined by the requirements of the module's PHY and may be as low as 0V and as high as 3.3V. The reference voltage output should be current limited on the module. In a case in which the reference is shorted to ground, the current must be limited to 250mA or less.	REF		Not Supported
GBE_LINK#	13	Ethernet controller 0 link indicator, active low.	O 3.3V PP	PD 1k	GBE0_LINK# is a bootstrap signal (see note below)
GBE_LINK100#	7	Ethernet controller 0 100Mbit/sec link indicator, active low.	O 3.3V PP	PU 4k99 2,5VSB	Not Supported. Internally connected to GBE_ACT#. GBE0_LINK100# is a bootstrap signal (see note below)
GBE_LINK1000#	8	Ethernet controller 0 1000Mbit/sec link indicator, active low.	O 3.3V PP	PD 1k	Not Supported. Internally connected to GBE_LINK#. GBE0_LINK1000# is a bootstrap signal (see note below)
GBE_ACT#	14	Ethernet controller 0 activity indicator, active low.	O 3.3V PP	PU 4k99 2,5VSB	GBE0_ACT# is a bootstrap signal (see note below)

 **Note**

The theoretical maximum performance of 1 Gbps Ethernet is limited to 470 Mbps (total for Tx and Rx) due to internal bus throughput limitations. The actual measured performance in optimized environment is up to 400 Mbps. For more information, consult NXP's Errata ERR004512.

Some signals have special functionality during the reset process. They may bootstrap some basic important functions of the module. For more information, refer to section 9.1 of this user's guide.

**Table 14 SATA Signal Descriptions**

Signal	Pin #	Description	I/O	PU/PD	Comment
SATA0_RX+ SATA0_RX-	35 37	Serial ATA channel 0, Receive Input differential pair.	I SATA		Supports Serial ATA specification, Revision 3.0
SATA0_TX+ SATA0_TX-	29 31	Serial ATA channel 0, Transmit Output differential pair.	O SATA		Supports Serial ATA specification, Revision 3.0
SATA1_RX+ SATA1_RX-	36 38	Serial ATA channel 1, Receive Input differential pair.	I SATA		Not supported
SATA1_TX+ SATA1_TX-	30 32	Serial ATA channel 1, Transmit Output differential pair.	O SATA		Not supported
SATA_ACT#	33	Serial ATA Led. Open collector output pin driven during SATA command activity.	OC 3.3V		Not supported



*The NXP® i.MX6 does not support SATA on Solo and Dual Core Lite CPUs. Only Quad Core and Dual Core variants support SATA.*

**Table 15 USB 2.0 Signal Descriptions**

Signal	Pin #	Description	I/O	PU/PD	Comment
USB_P0+ USB_P0-	96 94	Universal Serial Bus Port 0 differential pair.	I/O		USB 2.0 compliant. Backwards compatible to USB 1.1
USB_P1+ USB_P1-	95 93	Universal Serial Bus Port 1 differential pair. If USB_ID is LOW (default) = USB Host If USB_ID is tied HIGH = USB device (Client)	I/O		If USB_ID is LOW (default) = USB 2.0 compliant Host. Backwards compatible to USB 1.1 If USB_ID is HIGH = USB 2.0 Client. Backwards compatible to USB 1.1
USB_P2+ USB_P2-	90 88	Universal Serial Bus Port 2 differential pair.	I/O		USB 2.0 compliant. Backwards compatible to USB 1.1
USB_P3+ USB_P3-	89 87	Universal Serial Bus Port 3 differential pair.	I/O		USB 2.0 compliant. Backwards compatible to USB 1.1
USB_P4+ USB_P4- USB_SSRX1+ USB_SSRX1-	84 82	Universal Serial Bus Port 4 differential pair. Multiplexed with receive signal differential pairs for the Superspeed USB data path.	I		USB 2.0 compliant. Backwards compatible to USB 1.1. No USB 3.0 available
USB_P5+ USB_P5- USB_SSTX1+ USB_SSTX1-	83 81	Universal Serial Bus Port 5 differential pair. Multiplexed with transmit signal differential pairs for the Superspeed USB data path	I/O O		Not supported
USB_P6+ USB_P6- USB_SSRX0+ USB_SSRX0-	78 76	Universal Serial Bus Port 6 differential pair. Multiplexed with receive signal differential pairs for the Superspeed USB data path	I/O I		Not supported

USB_P7+ USB_P7- USB_SSTX0+ USB_SSTX0-	77 75	Universal Serial Bus Port 7 differential pair.  Multiplexed with transmit signal differential pairs for the Superspeed USB data path	I/O  O		Not supported
USB_0_1_OC#	86	Over current detect input 1. This pin is used to monitor the USB power over current of the USB Ports 0 and 1.	I 3.3VSB	PU 10k 3.3V	
USB_2_3_OC#	85	Over current detect input 2. This pin is used to monitor the USB power over current of the USB Ports 2 and 3.	I 3.3VSB	PU 10k 3.3V	
USB_4_5_OC#	80	Over current detect input 3. This pin is used to monitor the USB power over current of the USB Ports 4 and 5.	I 3.3VSB	PU 10k 3.3V	
USB_6_7_OC#	79	Over current detect input 4. This pin is used to monitor the USB power over current of the USB Ports 6 and 7.	I 3.3VSB	PU 10k 3.3VSB	Not supported
USB_ID	92	USB ID pin. Configures the mode of the USB Port 1. The resistance of this pin measured to ground is used to determine whether USB Port 1 is going to be used as USB Client to enable/ disable USB Client support. Please check the USB-OTG Reference of your chip manufacturer for further details.	Analog Output		Functions as USB_OTG_PEN "Added possibility to use Qseven goldfinger contact 92 (one wire bus) for HDMI-CEC or ENET 1588."
USB_VBUS	91	USB VBUS pin: - 5V tolerant - VBUS resistance has to be placed on the module - VBUS capacitance has to be placed on the carrier board	I 5.0V Passive Analog	PD 10k GND	
USB_OTG_PEN	56	USB Power enable pin for USB Port 1 Enables the Power for the USB-OTG port on the carrier board.	O CMOS 3.3V		

Table 16 SDIO/MMC Signal Descriptions

Signal	Pin #	Description	I/O	PU/PD	Comment
SDIO_CD#	43	SDIO Card Detect. This signal indicates when a SDIO/MMC card is present.	I/O 3.3V	PU 10k 3.3V	
SDIO_CLK	42	SDIO Clock. With each cycle of this signal a one-bit transfer on the command and each data line occurs. This signal has maximum frequency of 48 MHz.	O 3.3V		
SDIO_CMD	45	SDIO Command/Response. This signal is used for card initialization and for command transfers. During initialization mode this signal is open drain. During command transfer this signal is in push-pull mode.	I/O 3.3V OD/PP	PU 10k 3.3V	
SDIO_LED	44	SDIO LED. Used to drive an external LED to indicate when transfers occur on the bus.	O 3.3V	PU 10k 3.3V	
SDIO_WP	46	SDIO Write Protect. This signal denotes the state of the write-protect tab on SD cards.	I/O 3.3V	PU 10k 3.3V	
SDIO_PWR#	47	SDIO Power Enable. This signal is used to enable the power being supplied to a SD/MMC card device.	O 3.3V		Connected to GPIO

SDIO_DAT0	49	SDIO Data lines. These signals operate in push-pull mode.	I/O 3.3V PP		
SDIO_DAT1	48				
SDIO_DAT2	51				
SDIO_DAT3	50				
SDIO_DAT4	53				
SDIO_DAT5	52				
SDIO_DAT6	55				
SDIO_DAT7	54				

Table 17 HDA/I2S/SPDIF Signal Descriptions

Signal	Pin #	Description	I/O	PU/PD	Comment
HDA_RST# I2S_RST#	61	HD Audio/AC'97 Codec Reset. Multiplexed with I2S Codec Reset.	O 3.3V		Connected to GPIO
HDA_SYNC I2S_WS	59	Serial Bus Synchronization. Multiplexed with I2S Word Select from Codec.	O 3.3V		
HDA_BITCLK I2S_CLK	63	HD Audio/AC'97 24 MHz Serial Bit Clock from Codec. Multiplexed with I2S Serial Data Clock from Codec.	O 3.3V		
HDA_SDO I2S_SDO	67	HD Audio/AC'97 Serial Data Output to Codec. Multiplexed with I2S Serial Data Output from Codec.	O 3.3V		
HDA_SDI I2S_SDI	65	HD Audio/AC'97 Serial Data Input from Codec. Multiplexed with I2S Serial Data Input from Codec.	I 3.3V		



*The conga-QMX6 currently supports only I2S format.*

Table 18 LVDS Signal Descriptions

Signal	Pin #	Description	I/O	PU/PD	Comment
LVDS_PPEN	111	Controls panel power enable.	O 3.3V		
LVDS_BLEN	112	Controls panel Backlight enable.	O 3.3V		
LVDS_BLT_CTRL /GP_PWM_OUT0	123	Primary functionality is to control the panel backlight brightness via pulse width modulation (PWM). When not in use for this primary purpose it can be used as General Purpose PWM Output.	O 3.3V		
LVDS_A0+ LVDS_A0- eDP0_TX0+ eDP0_TX0-	99 101	LVDS primary channel differential pair 0.  Display Port primary channel differential pair 0.	O LVDS		
LVDS_A1+ LVDS_A1- eDP0_TX1+ eDP0_TX1-	103 105	LVDS primary channel differential pair 1.  Display Port primary channel differential pair 1.	O LVDS		

LVDS_A2+ LVDS_A2- eDP0_TX2+ eDP0_TX2-	107 109	LVDS primary channel differential pair 2.  Display Port primary channel differential pair 2.	O LVDS		
LVDS_A3+ LVDS_A3- eDP0_TX3+ eDP0_TX3-	113 115	LVDS primary channel differential pair 3.  Display Port primary channel differential pair 3.	O LVDS		
LVDS_A_CLK+ LVDS_A_CLK- eDP0_AUX+ eDP0_AUX-	119 121	LVDS primary channel differential pair clock lines.  Display Port primary auxiliary channel.	O LVDS		
LVDS_B0+ LVDS_B0- eDP1_TX0+ eDP1_TX0-	100 102	LVDS secondary channel differential pair 0.  Display Port secondary channel differential pair 0.	O LVDS		
LVDS_B1+ LVDS_B1- eDP1_TX1+ eDP1_TX1-	104 106	LVDS secondary channel differential pair 1.  Display Port secondary channel differential pair 1.	O LVDS		
LVDS_B2+ LVDS_B2- eDP1_TX2+ eDP1_TX2-	108 110	LVDS secondary channel differential pair 2.  Display Port secondary channel differential pair 2.	O LVDS		
LVDS_B3+ LVDS_B3- eDP1_TX3+ eDP1_TX3-	114 116	LVDS secondary channel differential pair 3.  Display Port secondary channel differential pair 3.	O LVDS		
LVDS_B_CLK+ LVDS_B_CLK- eDP1_AUX+ eDP1_AUX-	120 122	LVDS secondary channel differential pair clock lines.  Display Port secondary auxiliary channel.	O LVDS		
LVDS_DID_CLK /GP2_I2C_CLK	127	Primary functionality is DisplayID DDC clock line used for LVDS flat panel detection. If primary functionality is not used, it can be as General Purpose I <sup>2</sup> C bus clock line.	I/O 3.3V OD	PU 4k7 3.3V	
LVDS_DID_DAT /GP2_I2C_DAT	125	Primary functionality DisplayID DDC data line used for LVDS flat panel detection. If primary functionality is not used it can be as General Purpose I <sup>2</sup> C bus data line.	I/O 3.3V OD	PU 4k7 3.3V	
LVDS_BLC_CLK eDP1_HPD#	128	Control clock signal for external SSC clock chip. If the primary functionality is not used, it can be used as an embedded DisplayPort secondary Hotplug detection.	I/O 3.3V OD	PU 4k7 3.3V	Not supported
LVDS_BLC_DAT eDP0_HPD#	126	Control data signal for external SSC clock chip. If the primary functionality is not used, it can be used as an embedded DisplayPort primary Hotplug detection.	I/O 3.3V OD	PU 4k7 3.3V	Not supported

 **Note**

*The LVDS interface can be used either as a single channel or as a dual channel. It is also possible to use the LVDS interface as two independent single LVDS channels. To do this, it is recommended to configure the LVDS display in the bootloader.*

Table 19 DisplayPort Signal Descriptions

Signal	Pin #	Description	I/O	PU/PD	Comment
DP_LANE3+ DP_LANE3-	131 133	DisplayPort differential pair lines lane 3 (Shared with TMDS_CLK+ and TMDS_CLK-)	O PCIE		DisplayPort interface not supported
DP_LANE2+ DP_LANE2-	143 145	DisplayPort differential pair lines lane 2 (Shared with TMDS_LANE0+ and TMDS_LANE0-)	O PCIE		DisplayPort interface not supported
DP_LANE1+ DP_LANE1-	137 139	DisplayPort differential pair lines lane 1 (Shared with TMDS_LANE1+ and TMDS_LANE1-)	O PCIE		DisplayPort interface not supported
DP_LANE0+ DP_LANE0-	149 151	DisplayPort differential pair lines lane 0 (Shared with TMDS_LANE2+ and TMDS_LANE2-)	O PCIE		DisplayPort interface not supported
DP_AUX+ DP_AUX-	138 140	Auxiliary channel used for link management and device control. Differential pair lines.	I/O PCIE		DisplayPort interface not supported
DP_HDMI_HPD#	153	Hot plug detection signal that serves as an interrupt request.	I 3.3V		DisplayPort interface not supported



**Note**

The conga-QMX6 does not offer DisplayPort interface because the interface is not supported by the NXP® i.MX6 processor.

Table 20 HDMI® Signal Descriptions

Signal	Pin #	Description	I/O	PU/PD	
TMDS_CLK+ TMDS_CLK-	131 133	TMDS differential pair clock lines.		O TMDS	HDMI® interface
TMDS_LANE0+ TMDS_LANE0-	143 145	TMDS differential pair lines lane 0.		O TMDS	HDMI® interface
TMDS_LANE1+ TMDS_LANE1-	137 139	TMDS differential pair lines lane 1.		O TMDS	HDMI® interface
TMDS_LANE2+ TMDS_LANE2-	149 151	TMDS differential pair lines lane 2.		O TMDS	HDMI® interface
HDMI_CTRL_CLK	152	DDC based control signal (clock) for HDMI® device.	I/O 3.3V OD	PU 4k7 3.3V	HDMI® interface
HDMI_CTRL_DAT	150	DDC based control signal (data) for HDMI® device.	I/O 3.3V OD	PU 4k7 3.3V	HDMI® interface
DP_HDMI_HPD#	153	Hot plug detection signal that serves as an interrupt request.	I 3.3V	PD 100k	HDMI® interface



**Note**

On the conga-QMX6, only the HDMI® interface supports the Transition Minimized Differential Signaling (TMDS)

Table 21 LPC/GPIO Signal Descriptions

Signal	Pin #	Description	I/O	PU/PD	Comment
LPC_AD0 GPIO0	185	Multiplexed Command, Address and Data (LPC_AD[0..3]). Shared with General Purpose Input/Output [0..3]	I/O 3.3V		Shared with GPIO0
LPC_AD1 GPIO1	186				Shared with GPIO1
LPC_AD2 GPIO2	187				Shared with GPIO2
LPC_AD3 GPIO3	188				Shared with GPIO3
LPC_FRAME# GPIO5	190	LPC frame indicates the start of a new cycle or the termination of a broken cycle. Shared with General Purpose Input/Output 5	I/O 3.3V		Shared with GPIO5
LPC_LDRQ# GPIO7	192	LPC DMA request. General Purpose Input/Output 7	I/O 3.3V		Shared with GPIO7
LPC_CLK GPIO4	189	LPC clock. General Purpose Input/Output 4	I/O 3.3V		
SERIRQ GPIO6	191	Serialized Interrupt. General Purpose Input/Output 6	I/O 3.3V		Shared with GPIO6



**Note**

The eight LPC pins are configured by default as GPIO's. Additional eight GPIO pins can be achieved by configuring SDIO pins as GPIO. This can be programmed in the bootloader and in the kernel.

The conga-QMX6 does not support LPC interface.

Table 22 SPI Interface Signal Descriptions

Signal	Pin #	Description	I/O	PU/PD	Comment
SPI_MOSI	199	Master serial output/Slave serial input signal. SPI serial output data from Qseven® module to the SPI device.	O 3.3V		
SPI_MISO	201	Master serial input/Slave serial output signal. SPI serial input data from the SPI device to Qseven® module.	I 3.3V		
SPI_SCK	203	SPI clock output.	O 3.3V		
SPI_CS0#	200	SPI chip select 0 output.	O 3.3V		
SPI_CS1#	202	SPI Chip Select 1 signal is used as the second chip select when two devices are used. Do not use when only one SPI device is used.	O 3.3V		

Table 23 CAN Bus Signal Descriptions

Signal	Pin #	Description	I/O	PU/PD	Comment
CAN0_TX	129	CAN (Controller Area Network) TX output for CAN Bus channel 0. In order to connect a CAN controller device to the Qseven® module's CAN bus it is necessary to add transceiver hardware to the carrier board.	O 3.3V		
CAN0_RX	130	RX input for CAN Bus channel 0. In order to connect a CAN controller device to the Qseven® module's CAN bus it is necessary to add transceiver hardware to the carrier board.	I 3.3V		

Table 24 Input Power Signal Descriptions

Signal	Pin #	Description	I/O	PU/PD	Comment
VCC	211-230	Power Supply +5VDC ±5%.	P		
VCC_5V_SB	205-206	Standby Power Supply +5VDC ±5%.	P		
VCC_RTC	193	3 V backup cell input. VCC_RTC should be connected to a 3V backup cell for RTC operation and storage register non-volatility in the absence of system power. (VCC_RTC = 2.4 - 3.3 V).	P		
GND	1, 2, 23-25, 34, 39-40, 57-58, 73-74, 97-98, 117-118, 135-136, 141-142, 147-148, 159-160, 165-166, 183-184, 197-198	Power Ground.	P		

Table 25 Power Control Signal Descriptions

Signal	Pin #	Description	I/O	PU/PD	Comment
PWGIN	26	High active input for the Qseven® module indicates that power from the power supply is ready.	I 5V	PU 10k 5V	
PWRBTN#	20	Power Button: Low active power button input. This signal is triggered on the falling edge. <b>Note:</b> For proper detection, assert a pulse width of at least 16 ms.	I 3.3VSB	PU 10k 3.3V	

Table 26 Power Management Signal Descriptions

Signal	Pin #	Description	I/O	PU/PD	Comment
RSTBTN#	28	Reset button input. This input may be driven active low by an external circuitry to reset the Qseven® module. <b>Note:</b> For proper detection, assert a pulse width of at least 16 ms.	I 3.3V		
BATLOW#	27	Battery low input. This signal may be driven active low by external circuitry to signal that the system battery is low or may be used to signal some other external battery management event.	I 3.3VSB		Connected to GPIO
WAKE#	17	External system wake event. This may be driven active low by external circuitry to signal an external wake-up event.	I 3.3VSB		
SUS_STAT#	19	Suspend Status: indicates that the system will be entering a low power state soon.			Not supported
SUS_S3#	18	S3 State: This signal shuts off power to all runtime system components that are not maintained during S3 (Suspend to Ram), S4 or S5 states. The signal SUS_S3# is necessary in order to support the optional S3 cold power state.	O 3.3VSB		Connected to PMIC
SUS_S5#	16	S5 State: This signal indicates S4 or S5 (Soft Off) state.	O 3.3VSB		Connected to PMIC
SLP_BTN#	21	Sleep button. Low active signal used by the ACPI operating system to transition the system into sleep state or to wake it up again. This signal is triggered on falling edge. <b>Note:</b> For proper detection, assert a pulse width of at least 16 ms.	I 3.3VSB	PU 10k 3.3VSB	Connected to GPIO
LID_BTN#	22	LID button. Low active signal used by the ACPI operating system to detect a LID switch and to bring system into sleep state or to wake it up again. <b>Note:</b> For proper detection, assert a pulse width of at least 16 ms.	I 3.3VSB	PU 10k 3.3VSB	Connected to GPIO

Table 27 Miscellaneous Signal Descriptions

Signal	Pin #	Description	I/O	PU/PD	Comment
WDTRIG#	70	Watchdog trigger signal. This signal restarts the watchdog timer of the Qseven® module on the falling edge of a low active pulse.	I 3.3V		Connected to GPIO
WDOUT	72	Watchdog event indicator. High active output used for signaling a missing watchdog trigger. Will be deasserted by software, system reset or a system power down.	O 3.3V		Connected to GPIO See note below
GP0_I2C_CLK	66	General Purpose I <sup>2</sup> C bus #0 clock line	I/O 3.3V OD	PU 4k7 3.3V	
GP0_I2C_DAT	68	General Purpose I <sup>2</sup> C bus #0 data line	I/O 3.3V OD	PU 4k7 3.3V	
SMB_CLK /GP1_I2C_CLK	60	Clock line of System Management Bus. Multiplexed with General Purpose I <sup>2</sup> C bus #1 clock line	I/O 3.3VSB OD	PU 4k7 3.3V	Connected to I2C
SMB_DAT /GP1_I2C_DAT	62	Data line of System Management Bus. Multiplexed with General Purpose I <sup>2</sup> C bus #1 data line	I/O 3.3VSB OD	PU 4k7 3.3V	Connected to I2C
SMB_ALERT#	64	System Management Bus Alert input. This signal may be driven low by SMB devices to signal an event on the SM Bus.	I/O 3.3VSB OD	PU 10k 3.3V	Connected to GPIO.
SPKR /GP_PWM_OUT2	194	Primary functionality is output for audio enunciator, the “speaker” in PC AT systems. When not in use for this primary purpose it can be used as General Purpose PWM Output.	O 3.3V		Not supported.
BIOS_DISABLE# /BOOT_ALT#	41	Pin is used to select Boot mode.	I 3.3V	PU 4k7 3.3V	

RSVD	132, 134, 144, 146, 154	Do not connect	NC		
GP_1-Wire_Bus	124	General Purpose 1-Wire bus interface. Can be used for consumer electronics control bus (CEC) of HDMI®.	I/O 3.3V		Currently implemented as HDMI® Consumer Electronics Control Bus.



### Note

The WDOOUT signal is high by default on the conga-QMX6. Implement a reverse circuit on the carrier board to set the signal low by default.

Table 28 Manufacturing/JTAG Signal Descriptions

Signal	Pin #	Description	I/O	PU/PD	Comment
MFG_NC0	207	This pin is reserved for manufacturing and debugging purposes. May be used as JTAG_TCK signal for boundary scan purposes during production or as a vendor specific control signal. When used as a vendor specific control signal the multiplexer must be controlled by the MFG_NC4 signal.	NA	NA	
MFG_NC1	209	This pin is reserved for manufacturing and debugging purposes. May be used as JTAG_TDO signal for boundary scan purposes during production. May also be used, via a multiplexer, as a UART_TX signal to connect a simple UART for firmware and boot loader implementations. In this case the multiplexer must be controlled by the MFG_NC4 signal.	NA	NA	See caution statement below
MFG_NC2	208	This pin is reserved for manufacturing and debugging purposes. May be used as JTAG_TDI signal for boundary scan purposes during production. May also be used, via a multiplexer, as a UART_RX signal to connect a simple UART for firmware and boot loader implementations. In this case the multiplexer must be controlled by the MFG_NC4 signal.	NA	NA	See caution statement below
MFG_NC3	210	This pin is reserved for manufacturing and debugging purposes. May be used as JTAG_TMS signal for boundary scan purposes during production. May also be used, via a multiplexer, as vendor specific BOOT signal for firmware and boot loader implementations. In this case the multiplexer must be controlled by the MFG_NC4 signal.	NA	NA	
MFG_NC4	204	This pin is reserved for manufacturing and debugging purposes. May be used as JTAG_TRST# signal for boundary scan purposes during production. May also be used as control signal for a multiplexer circuit on the module enabling secondary function for MFG_NC0..3 ( JTAG / UART ). When MFG_NC4 is high active it is being used for JTAG purposes. When MFG_NC4 is low active it is being used for UART purposes.	NA	NA	



### Note

The MFG\_NC0..4 pins are reserved for manufacturing and debugging purposes. It's recommended to route the signals to a connector on the carrier board. The carrier board must not drive the MFG\_NC-pins or have pull-up or pull-down resistors implemented for these signals. MFG\_NC0..4 are defined to have a voltage level of 3.3V. It must be ensured that the carrier board has the correct voltage levels for JTAG/UART signals originating from the module. For this reason, a level shifting device may be required on the carrier board to guarantee that these voltage levels are correct in order to prevent damage to the module. More information about implementing a carrier board multiplexer can be found in the Qseven® Design Guide.



## Caution

The MFG\_NC4 pin is high active on the conga-QMX6 module. This means that the MFG interface on the edge connector functions by default as JTAG interface. Therefore, do not use the MFG interface for UART purposes or externally pull the MFG\_NC4 pin to ground. Failure to adhere to this warning may result to back-driving which can damage the module.

If you need the UART function on the MFG interface, then you require a customized conga-QMX6. For more information, contact congatec support.

Table 29 Thermal Management Signal Descriptions

Signal	Pin #	Description	I/O	PU/PD	Comment
THRM#	69	Thermal Alarm active low signal generated by the external hardware to indicate an over temperature situation. This signal can be used to initiate thermal throttling.	I 3.3V	PU 10k 3.3V	Connected to GPIO
THRMTRIP#	71	Thermal Trip indicates an overheating condition of the processor. If 'THRMTRIP#' goes active the system immediately transitions to the S5 State (Soft Off).	O 3.3V		Connected to GPIO

Table 30 Fan Control Signal Descriptions

Signal	Pin #	Description	I/O	PU/PD	Comment
FAN_PWMOUT /GP_PWM_OUT1	196	Primary functionality is fan speed control. Uses the Pulse Width Modulation (PWM) technique to control the Fan's RPM based on the CPU's die temperature. When not in use for this primary purpose it can be used as General Purpose PWM Output.	O 3.3V OC		
FAN_TACHOIN /GP_TIMER_IN	195	Primary functionality is fan tachometer input. When not in use for this primary purpose it can be used as General Purpose Timer Input.	I 3.3V		Connected to GPIO

## 9.1 Bootstrap Signals

Table 31 Bootstrap Signal Descriptions

Signal	Pin #	Description of Bootstrap Signal	I/O	PU/PD	Comment
GBE_LINK#	13	Ethernet controller 0 link indicator, active low.	O 2.5VSB	PU 4k99	GBE0_LINK# is a bootstrap signal (see note below)
GBE_LINK100#	7	Ethernet controller 0 100Mbit/sec link indicator, active low.	O 2.5VSB	PU 1k 3.3V	Not Supported. Internally connected to GBE_ACT#. GBE0_LINK100# is a bootstrap signal (see note below)
GBE_LINK1000#	8	Ethernet controller 0 1000Mbit/sec link indicator, active low.	O 2.5VSB	PU 4k99	Not Supported. Internally connected to GBE_LINK#. GBE0_LINK1000# is a bootstrap signal (see note below)
GBE_ACT#	14	Ethernet controller 0 activity indicator, active low.	O 2.5VSB	PD 1k 3.3V	GBE0_ACT# is a bootstrap signal (see note below)



### Caution

The signals listed in the table above are used as chipset configuration straps during system reset. In this condition (during reset), they are inputs that are pulled to the correct state by either Qseven® internally implemented resistors or chipset internally implemented resistors that are located on the module. No external DC loads or external pull-up or pull-down resistors should change the configuration of the signals listed in the above table. External resistors may override the internal strap states and cause the Qseven® module to malfunction and/or cause irreparable damage to the module.

Additionally, if it is necessary to have link and activity LEDs connected to GBE\_LINK# and GBE\_ACT# on the carrier board, then you have to use buffers. Without a buffer, the strapping becomes active and this causes the PHY to be programmed with wrong address.

# 10 Onboard Interfaces and Devices

## 10.1 UART/RS-232 Debug Port

The conga-QMX6 is equipped with a six-pin RS232 connector onboard the conga-QMX6. This RS-232 debug port is connected to the NXP® i.MX6 UART1 and UART2 pins via the MAXIM-3232 transceiver. The transceiver is guaranteed to run at data rates of 250kbps in normal operating mode, while maintaining RS-232 output levels.

Refer to section 5.2 for more information about the UART interface.

Table 32 UART Signal Descriptions

Pin #	Signal (Molex Connector)	D-SUB 1 (Console)	D-SUB 2	Description	Color
1	DCE1_TXT	NC	Pin 2	i.MX6 UART 5 Serial Data Transmitter	Red
2	NC	NC	NC	Not Connected	-
3	GND	Pin 5	Pin 5	Ground	White
4	DCE2_TXT	Pin 2	NC	UART 2 Serial Data Transmitter	Black
5	DCE2_RX	Pin 3	NC	UART 2 Serial Data Receiver	Orange
6	DCE1_RX	NC	Pin 3	i.MX6 UART 5 Serial Data Receiver	Purple

### Note

The RS232 adapter cable (PN: 48000023) for the onboard UART interface is included in the congatec Qseven Evaluation kit. You can also order this cable separately from congatec GmbH. For more information, contact your congatec sales representative.

## 10.2 MIPI/CMOS Camera

The NXP® i.MX6 Image Processing Unit (IPU) provides connectivity to cameras via the MIPI/CSI-2 transmitter and maintains image manipulation and processing with adequate synchronization and control. The Camera Serial Interface (CSI) controls the camera port and provides interface to an image sensor or a related device. The role of the camera ports is to receive input from video sources and to provide support for time-sensitive signals to the camera. Non-time-sensitive controls such as configuration, reset are performed by the ARM platform through I2C interface or GPIO signals

The table below shows the conga-QMX6 revision C.x and E.x MIPI pinout description. The pinout complies with the SGET Qseven Camera Feature Specification (an addendum to the Qseven Specification 2.0).

**Table 33 MIPI Signal Descriptions**

Pin	Signal	Description	I/O Type	I/O	Comment
1	CAM_PWR	3.3V +/- 5% supply voltage to power the camera device	3.3V Power Output	P	
2	CAM_PWR	3.3V +/- 5% supply voltage to power the camera device	3.3V Power Output	P	
3	CAM0_CSI_D0+	CSI2 Camera 0 Data Lane 0+	D-PHY	I	
4	CAM0_CSI_D0-	CSI2 Camera 0 Data Lane 0-	D-PHY	I	
5	GND			P	
6	CAM0_CSI_D1+	CSI2 Camera 0 Data Lane 1+	D-PHY	I	
7	CAM0_CSI_D1-	CSI2 Camera 0 Data Lane 1-	D-PHY	I	
8	GND			P	
9	CAM0_CSI_D2+	CSI2 Camera 0 Data Lane 2+	D-PHY	I	
10	CAM0_CSI_D2-	CSI2 Camera 0 Data Lane 2-	D-PHY	I	
11	CAM0_RST#	Camera 0 Reset (low active)	CMOS 1.8V	O	
12	CAM0_CSI_D3+	CSI2 Camera 0 Data Lane 3+	D-PHY	I	
13	CAM0_CSI_D3-	CSI2 Camera 0 Data Lane 3-	D-PHY	I	
14	GND			P	
15	CAM0_CSI_CLK+	CSI2 Camera 0 Differential Clock+ (Strobe)	D-PHY	I	
16	CAM0_CSI_CLK-	CSI2 Camera 0 Differential Clock- (Strobe)	D-PHY	I	
17	GND			P	
18	CAM0_I2C_CLK	Camera 0 Control Interface, CLK. (I <sup>2</sup> C like interface)	CMOS 1.8V OD	O	
19	CAM0_I2C_DAT	Camera 0 Control Interface, DATA. (I <sup>2</sup> C like interface)	CMOS 1.8V OD	I/O	
20	CAM0_ENA#	Camera 0 Enable (low active)	CMOS 1.8V	O	
21	MCLK	Master Clock. May be used by Cameras to drive it's internal PLL Frequency range: 6...27 MHz	CMOS 1.8V	O	
22	CAM1_ENA#	Camera 1 Enable (low active)	CMOS 1.8V	O	
23	CAM1_I2C_CLK	Camera 1 Control Interface, CLK. (I <sup>2</sup> C like interface)	CMOS 1.8V OD	O	Not Connected
24	CAM1_I2C_DAT	Camera 1 Control Interface, DATA. (I <sup>2</sup> C like interface)	CMOS 1.8V OD	I/O	Not Connected

25	GND			P	
26	CAM1_CSI_CLK+	CSI2 Camera 1 Differential Clock+ (Strobe)	D-PHY	I	Not Connected
27	CAM1_CSI_CLK-	CSI2 Camera 1 Differential Clock- (Strobe)	D-PHY	I	Not Connected
28	GND			P	
29	CAM1_CSI_D0+	CSI2 Camera 1 Data Lane 0+	D-PHY	I	Not Connected
30	CAM1_CSI_D0-	CSI2 Camera 1 Data Lane 0-	D-PHY	I	Not Connected
31	CAM1_RST#	Camera 1 Reset (low active)	CMOS 1.8V	O	
32	CAM1_CSI_D1+	CSI2 Camera 1 Data Lane 1+	D-PHY	I	Not Connected
33	CAM1_CSI_D1-	CSI2 Camera 1 Data Lane 1-	D-PHY	I	Not Connected
34	GND			P	
35	CAM0_GPIO	GPIO for Camera 0	CMOS 1.8V	I/O	
36	CAM1_GPIO	GPIO for Camera 1	CMOS 1.8V	I/O	Also for alternative camera functions like flashlight (not specified in SGET spec.)



### Note

#### **conga-QMX6 Revision B.x:**

For the camera interface on conga-QMX6 revision B.x to function correctly:

1. Use the latest kernel on the congatec git server. If you use older kernels (3.0.35\_1.1.0 and 3.0.35\_4.1.0), then you require a patch (available on the git server) to provide the correct supply voltage for the camera module. You do not need this patch if the camera is connected on the conga-MCB mini carrier board.
2. If you intend to connect camera module ACA1 to the camera interface, then make sure you use hardware revision X.1 of camera module ACA1 to provide 2.5V compliant signals.
3. Set the voltage level of the camera interface to 2.5V. You can achieve this voltage level in QMX6 bootloader version 2013.04 (cgt\_imx\_v2013.04\_3.10.17\_1.0.0) by setting the environment variable "lv\_mipi" to the value "2V5".

For more information about the camera interface and the related requirements/modifications to the hardware, contact your dedicated congatec support representative.

#### **conga-QMX6 Revision C.x and E.x:**

The conga-QMX6 revision C.x provides 3.3V to the camera interface as defined by the SGET Camera Feature Specification. Because of this voltage level, the ACA1 hardware revision X.x is not compatible with the camera interface of conga-QMX6 revision C.x and E.x. Therefore, use only hardware revision A.x of the camera module ACA1 (See the caution below).



## Caution

The ACA1 camera module, hardware revision X.x is not compatible with the conga-QMX6 C.x and E.x because of the difference in supply voltage levels. Therefore, use only hardware revision A.x of camera module ACA1 or newer on conga-QMX6 revision C.x and E.x.

Do not use hardware revision X.x of the ACA1 camera module on the conga-QMX6 C.x or E.x. You will damage the camera module and/or the QMX6 module if you do not adhere to this instruction.

## 10.3 JTAG Interface

The conga-QMX6 offers an onboard 10-pin JTAG interface. For compatible JTAG adapters, contact congatec support team or use the Nit6X\_JTAG adapter Boundary Devices.

Table 34 JTAG Interface Signal Descriptions

Pin #	Signal
1	P3V3_DELAYED
2	JTAG_TMS_B
3	GND
4	JTAG_TCK_B
5	GND
6	JTAG_TDO_B
7	JTAG_MOD_B
8	JTAG_TDI_B
9	JTAG_nTRST
10	JTAG_RSTBTN#

## 10.4 SPI Flash

Onboard the conga-QMX6 is a 32 Mbit SPI flash memory. This flash memory contains the bootloader and is directly connected to the ECSPi-1 interface of the i.MX6 processor.

The NXP® i.MX6 processor is programmed to boot from the SPI flash.

## 10.5 Android Buttons

Table 35 Android Button Signal Descriptions

Onboard the conga-QMX6 is an eight pin connector for implementing android buttons. The signals are directly connected to the NXP® i.MX6 processor.

Signal	Pin #	Description	I/O
PWRBTN#	1	Power button signal	
KEY_VOL_UP	2	Increases volume	GPIO7_13
HOME	3	Returns to the main home screen	GPIO2_4
SEARCH	4	Brings up the search function	GPIO2_3
BACK	5	Takes you a level back in an app or a page back in a browser	GPIO2_2
MENU	6	Displays additional options in an application	GPIO2_1
KEY_VOL_DN	7	Decreases volume	GPIO4_5
GND	8	Ground	

## 10.6 DDR3L Memory

The conga-QMX6 offers up to 4GB DDR3L SDRAM memory onboard. The memory modules are connected directly to the DDR ports of the NXP® i.MX6 processor.

## 10.7 eMMC

The conga-QMX6 revision E.x offers a 32GB eMMC module onboard. The onboard eMMC is a nand flash device and it is routed directly to the SDIO port 3 of the NXP® i.MX6 processor. Eight lanes are used for data. Changes to the onboard eMMC may occur during the lifespan of the module in order to keep up with the rapidly changing eMMC technology. The performance of the newer eMMC may vary depending on the eMMC technology.



### Note

*For adequate operation of the eMMC, ensure that at least 15 % of the eMMC storage is reserved for vendor-specific functions.*

## 10.8 Micro SD

The conga-QMX6 offers an onboard micro SD connector (backside of the module). It is connected to the SDIO port 2 of the NXP® i.MX6 processor. Four lanes are used for data. Revision E.x supports 1.8V and 3.3V cards. Previous revisions only support 3.3V cards.