

Model. No.	FYL-5012HD1C
Rev.	A

## PRODUCT SPECIFICATION

**Model No. : : FYL-5012HB1C**

Descriptions:
■ Dice material: GaP
■ Emitting Color: Hi Red
■ Device Outline: Φ5mm round type.
■ Lens Type: Red diffused



CUSTOMER APPROVED SIGNATURES	APPROVED BY	CHECKED BY	PREPARED BY

NINGBO FORYARD OPTOELECTRONICS CO.,LTD.  
 Add:NO.115 Qixin Road Ningbo Zhejiang China  
 Tel: 0086-574-87933652 87927870 87922206  
 Fax: 0086-574-87927917  
 E-mail: Sales@foryard.com ( General )  
[Http://www.foryard.com](http://www.foryard.com)

Zip:315051

## Features

1. Low power consumption.
2. High efficiency.
3. General purpose leads.
4. RoHs compliant.

## Package configuration

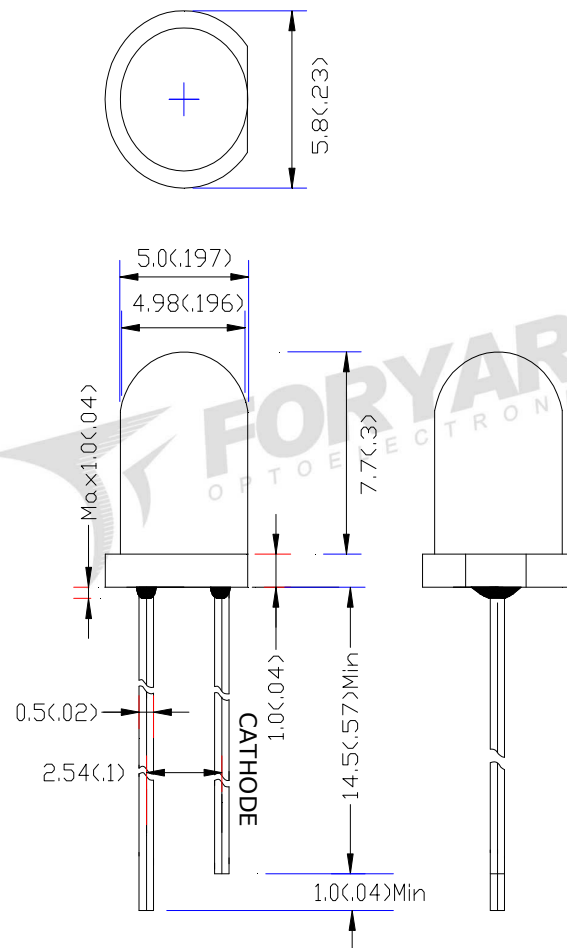

### Notes:

1. All dimensions are millimeters (inches)
2. Tolerance is  $\pm 0.25\text{mm}$  (.010") unless otherwise noted.
3. The specifications, characteristics and technical data described in the datasheet are subject to change without prior notice.

**Absolute maximum ratings(Ta=25° c)**

Parameter	MAX.	Unit
Power Dissipation	75	mW
Peak Forward Current (1/10 Duty Cycle, 0.1ms Pulse Width)	100	mA
Continuous Forward Current	30	mA
Derating Linear From 50°C	0.4	mA/°C
Reverse Voltage	5	V
Operating Temperature Range	-40°C to +85°C	
Storage Temperature Range	-40°C to +100°C	
Lead Soldering Temperature[4mm(.157") From Body]	260°C for 5 Seconds	

**Electrical and optical characteristics(Ta=25° c)**

Parameter	Symbol	Min.	Typ.	Max.	Unit	Test Condition
Luminous Intensity	$I_v$	-	10	-	mcd	$I_F=20mA$
Viewing Angle	$2\theta_{1/2}$	-	30	-	Deg	
Peak Emission Wavelength	$\lambda_p$	-	700	-	nm	
Dominant Wavelength	$\lambda_d$	-	660	-	nm	
Spectral Line Half-Width	$\Delta\lambda$	-	100	-	nm	
Forward Voltage	$V_F$	1.8	2.3	2.7	V	
Reverse Current	$I_R$			10	$\mu A$	$V_R=5V$

## Typical Electrical Characteristics Curves

(25 ° c Ambient Temperature Unless Otherwise Noted)

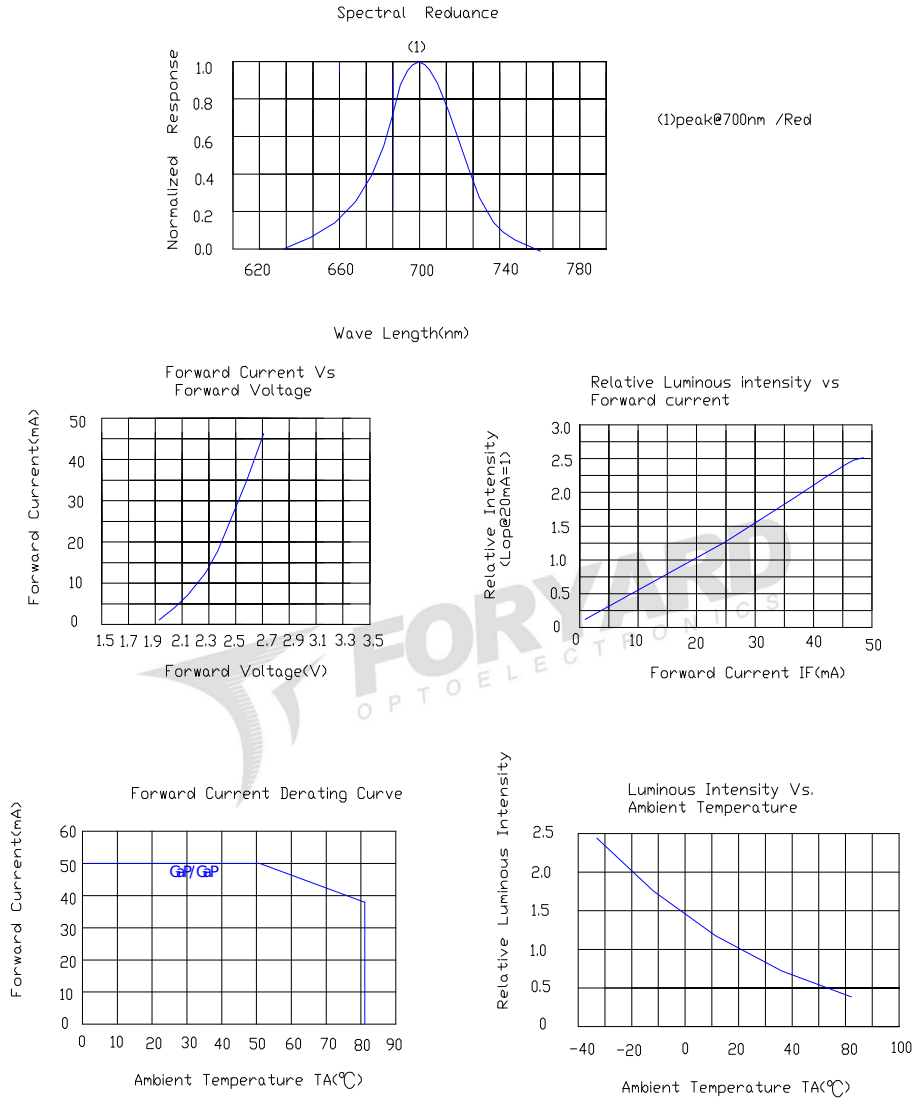

### Radiation pattern.

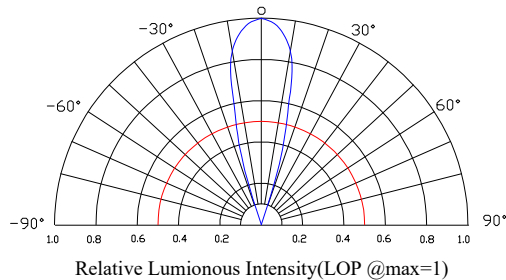

Model. No.	FYL-5012HD1C
Rev.	A

**LAMP PACKING.**

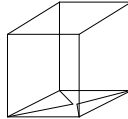

5mm 1000PCS/Polybag

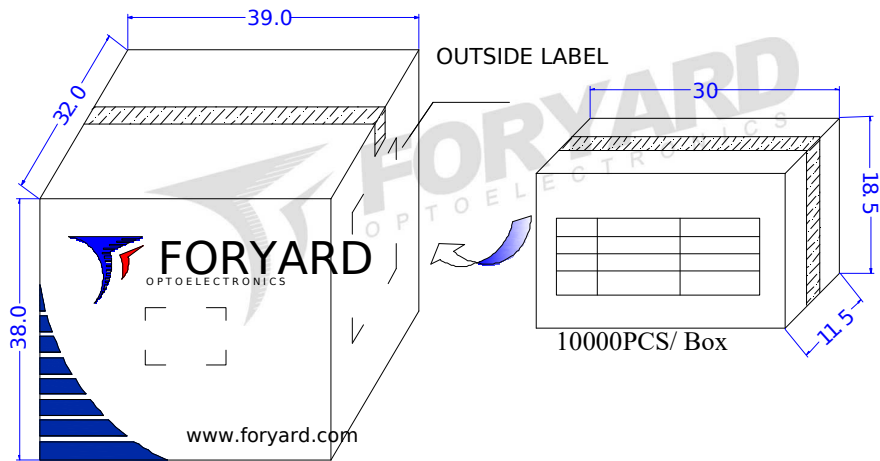
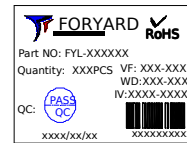

60000PCS/ Carton



OUTSIDE LABEL